

EBARA

	Page
- SPECIFICATIONS	200
SELECTION CHART	201
TYPE KEY AND CURVE SPECIFICATIONS	211
PERFORMANCE CURVE ENR 32-125	213
PERFORMANCE CURVE ENR 32-160A	214
PERFORMANCE CURVE ENR 32-160B	215
PERFORMANCE CURVE ENR 32-200A	216
PERFORMANCE CURVE ENR 32-200B	217
PERFORMANCE CURVE ENR 32-250	218
PERFORMANCE CURVE ENR 40-125	219
PERFORMANCE CURVE ENR 40-160	220
PERFORMANCE CURVE ENR 40-200	221
PERFORMANCE CURVE ENR 40-250	222
PERFORMANCE CURVE ENR 40-315	223
PERFORMANCE CURVE ENR 50-125	224
PERFORMANCE CURVE ENR 50-160	225
PERFORMANCE CURVE ENR 50-200	226
PERFORMANCE CURVE ENR 50-250	227
PERFORMANCE CURVE ENR 50-315	228
PERFORMANCE CURVE ENR 65-125	229
PERFORMANCE CURVE ENR 65-160	230
PERFORMANCE CURVE ENR 65-200	231
PERFORMANCE CURVE ENR 65-250	232
PERFORMANCE CURVE ENR 80-160	233
PERFORMANCE CURVE ENR 80-200	234
PERFORMANCE CURVE ENR 80-250	235
PERFORMANCE CURVE ENR 100-160	236
PERFORMANCE CURVE ENR 100-200	237
PERFORMANCE CURVE ENR 100-250	238
PERFORMANCE CURVE ENR 125-200	239
- CONSTRUCTIONS	300
SECTIONAL VIEW	300

- DIMENSIONS AND WEIGHT	400
PUMP WITH MOTOR 32-40	400
PUMP WITH MOTOR 40-50	401
PUMP WITH MOTOR 65-80-100	402
PUMP WITH MOTOR 100-125	403
PUMP WITHOUT MOTOR	404
- TECHNICAL DATA	500
MOTOR DATA 32-40-50	500
MOTOR DATA 50-65	501
MOTOR DATA 80-100-125	502
NOISE DATA	503

SPECIFICATION

50Hz

Rev. 0

PUMP		
Liquid Handled	Type of liquid	Clean water
	Temperature [°C]	min. -20°C max +120°C
Maximum working pressure	[MPa]	1.47
Flange		UNI 2236
Counterflange (On request)		UNI 2247
Construction	Impeller	Closed centrifugal type
	Shaft seal type	Mechanical seal
	Bearing	Sealed ball bearing
Pipe Connection	Suction	Flange to DIN 2532
	Discharge	Flange to DIN 2532
Material	Casing	CAST IRON
	Impeller	CAST IRON / BRONZE
	Shaft seal	SiC/Carbon/EPDM
	Shaft	AISI 420
	Bracket	CAST IRON
Applicable standard of test		ISO 9906 – Annex A

MOTOR		
Type	Electric - TEFC Three Phase	
Efficiency level (Reg. 640/2009)	IE2	
No. of Poles	2	
Rotation speed [min ⁻¹]	≈2900	
Insulation Class	F	
Protection degree (CEI EN 60034-5)	IP 55	
Power rating	[kW]	0.75 ÷ 110
	[HP]	1 ÷ 150
Frequency [Hz]	50	
Voltage [V]	400/690 ±10%	
Over load protection	Provided by the user	
Casing material	Cast Iron	

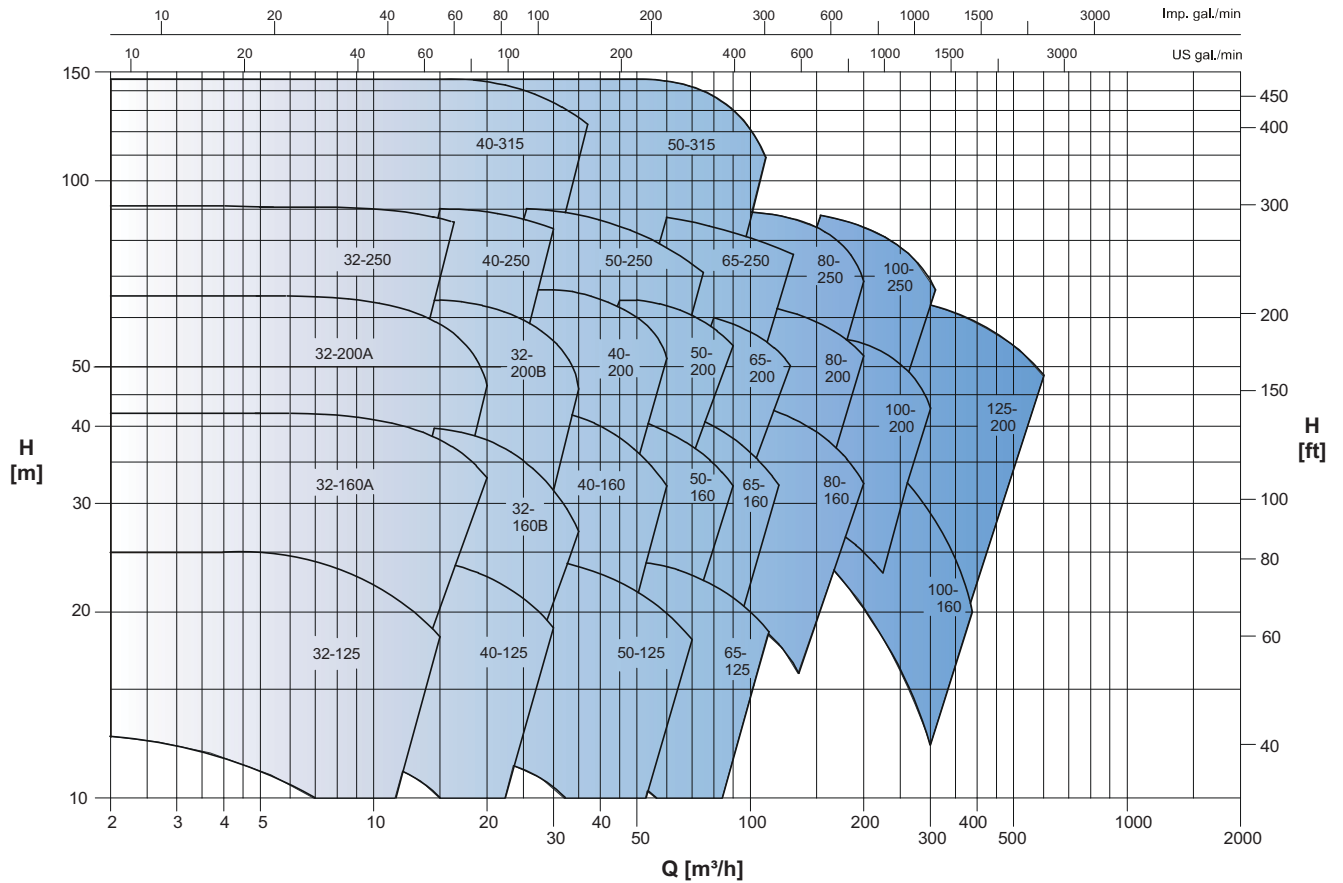

ENR 2 Poles: 32-125 Version

Pump type ENR	Q=Capacity											
	m³/h 0	2	4	6	8	10	12	14	16	18	20	22
Three Phase	l/min 0	33,3	67	100	133	167	200	233	267	300	333	367
H=Total manometric head in meters												
ENR 32-125 Ø100	11,5	11,4	11	10,8	10,5	9,8	8	6	-	-	-	-
ENR 32-125 Ø110	14,5	14,5	14,3	14	13,8	12,8	11,8	10	8	-	-	-
ENR 32-125 Ø120	17,5	17,5	17,3	17,1	16,9	16	15	13,8	12	10	-	-
ENR 32-125 Ø130	22	22	22	21,9	21,7	21,2	20	18,8	17,7	15,3	13	-
ENR 32-125 Ø140	26	26	26	26	25,9	25,3	25	24	22,9	21	18,4	16

SELECTION CHART

50Hz

Rev. 0

ENR 2 Poles: 32-160 A Version

Pump type ENR	Q=Capacity												
	m ³ /h 0	2	4	6	8	10	12	13,5	15,2	16,8	18	19,5	20,5
Three Phase	l/min 0	33,3	67	100	133	167	200	225	253	280	300	325	342
H=Total manometric head in meters													
ENR 32-160A Ø130	22,5	22,5	22,5	22,4	21	19,9	17,4	15	-	-	-	-	-
ENR 32-160A Ø140	27	26,9	26,5	25,5	24,5	24,5	22,5	20	17,5	-	-	-	-
ENR 32-160A Ø150	30,5	30,7	30,6	30,2	29,5	29,5	27,5	25,5	22,5	20	-	-	-
ENR 32-160A Ø160	35,5	35,8	36	35,4	34,5	34,8	33	31,5	28,5	26,5	23	-	-
ENR 32-160A Ø168	40	41	40,5	40	39,8	39,7	37,8	37	35	32,5	30	27	-
ENR 32-160A Ø175	44,5	45	45	45	44,5	43,5	42,5	41	39	37,5	35	32,5	31

ENR 2 Poles: 32-160 B Version

Pump type ENR	Q=Capacity										
	m ³ /h 0	5	10	15	20	24,5	27	29	32	34	36
Three Phase	l/min 0	83,3	167	250	333	408	450	483	533	567	600
H=Total manometric head in meters											
ENR 32-160B Ø130	22,3	22,4	21,5	20	17,5	15	-	-	-	-	-
ENR 32-160B Ø140	26,3	26,4	25,7	24,5	24,9	18,5	17,5	-	-	-	-
ENR 32-160B Ø150	30	30,2	30	28,5	27	26	22	20	-	-	-
ENR 32-160B Ø160	35	35	34,8	33,5	31,5	28	27	25	22,5	-	-
ENR 32-160B Ø168	39	38,8	38,5	37,5	35,5	35,2	31,5	29	27,3	25	-
ENR 32-160B Ø175	42,5	42,5	42,5	42	40	37,5	35,3	33	31,5	28	27,5

ENR 2 Poles: 32-200 A Version

Pump type ENR	Q=Capacity												
	m ³ /h 0	3	7	10	12	14	15	18	19	21	22,5	23	24
Three Phase	l/min 0	50	117	167	200	233	250	300	317	350	375	383	400
H=Total manometric head in meters													
ENR 32-200A Ø170	37	36	35,5	34	33	31	30	27	-	-	-	-	-
ENR 32-200A Ø180	42	42	41,5	40	38	37	36	33	30	-	-	-	-
ENR 32-200A Ø190	48	48	47	46	45	44	42	39	37	35	-	-	-
ENR 32-200A Ø200	55	55	54	53,5	52	51	50	46	44	42	39	-	-
ENR 32-200A Ø207	60	60	59	58	57	56	55	52	51	47	45	42,5	-
ENR 32-200A Ø214	65	66	65	64	63	62	61	58	56	53,5	50	48	46

SELECTION CHART

50Hz

Rev. 0

ENR 2 Poles: 32-200 B Version

Pump type ENR Three Phase	Q=Capacity										
	m ³ /h 0	5	10	15	20	25	26,9	29	31,5	33	35
	l/min 0	83,3	167	250	333	417	448	483	525	550	583
	H=Total manometric head in meters										
ENR 32-200B Ø170	37	37	36	35	32,5	26	-	-	-	-	-
ENR 32-200B Ø180	44	43,5	43	42	40	34	32	-	-	-	-
ENR 32-200B Ø190	49	48,5	48	47	46	42	40	35	-	-	-
ENR 32-200B Ø200	56	55	55	54	53,5	50	48	44	41	-	-
ENR 32-200B Ø207	61	61	60,5	60	59	56	54	52	48	45	-
ENR 32-200B Ø214	67	66,5	65,5	65,5	65	63	61	58	56	53	50

ENR 2 Poles: 32-250 Version

Pump type ENR Three Phase	Q=Capacity											
	m ³ /h 0	4	8	10	12	14	16	18	19,1	19,9	21	21,5
	l/min 0	66,7	133	167	200	233	267	300	318	332	350	358
	H=Total manometric head in meters											
ENR 32-250 Ø215	56,5	55	55	54	52	49	45	39	-	-	-	-
ENR 32-250 Ø225	65	65	64	62,5	60	58	54	48,5	45	-	-	-
ENR 32-250 Ø235	72,5	72,5	71	70	68	65	62	57	54	52,5	-	-
ENR 32-250 Ø245	80	80	80	79	77	75	72	67	65	61	60	-
ENR 32-250 Ø255	90	90	89	88	87	85	82	77	75	71	69	68

ENR 2 Poles: 40-125 Version

Pump type ENR Three Phase	Q=Capacity										
	m ³ /h 0	5	10	15	20	25	26,5	28	30	33	36
	l/min 0	83,3	167	250	333	417	442	467	500	550	600
	H=Total manometric head in meters										
ENR 40-125 Ø100	12	11,9	11,8	10,2	9	5,8	4,2	-	-	-	-
ENR 40-125 Ø110	14,2	14,2	14	13,8	12	8,7	8	7	-	-	-
ENR 40-125 Ø120	17,9	17,9	17,8	16,2	15,8	13	12	11	9,8	-	-
ENR 40-125 Ø130	22	22	22	21,8	20	18	17,5	16,2	14,8	12,5	-
ENR 40-125 Ø140	26	26,1	26	26	25	23,8	22,6	21	20,2	18	15

SELECTION CHART

50Hz

Rev. 0

ENR 2 Poles: 40-160 Version

Pump type ENR Three Phase	Q=Capacity												
	m ³ /h 0	10	15	20	25	30	35	42	47	52	57	62	65
	l/min 0	166,7	250	333	417	500	583	700	783	867	950	1033	1083
H=Total manometric head in meters													
ENR 40-160 Ø130	22,5	22,5	22,3	22	21	20	17,6	15	-	-	-	-	-
ENR 40-160 Ø140	27	27	26,5	25,5	25	24,8	22,5	20	17,5	-	-	-	-
ENR 40-160 Ø150	31,5	31	30,5	30	29,9	28,5	27,5	25,5	23	21	-	-	-
ENR 40-160 Ø160	36	35,4	35	35	34,9	33	32,5	31,5	28,5	27	24	-	-
ENR 40-160 Ø168	39,5	39,8	39,5	39	38	37,5	36,5	35	33	32	30	26,5	-
ENR 40-160 Ø175	43	43	42,5	42,5	42	41,5	41	39,5	37,5	35,5	33	30,5	26

ENR 2 Poles: 40-200 Version

Pump type ENR Three Phase	Q=Capacity												
	m ³ /h 0	10	15	20	27,5	35	42,5	47,5	52	55	59	62,5	65
	l/min 0	166,7	250	333	458	583	708	792	867	917	983	1042	1083
H=Total manometric head in meters													
ENR 40-200 Ø170	39,8	40	39,9	39,5	38,5	36	33	30	-	-	-	-	-
ENR 40-200 Ø180	45,5	45,5	45,5	45,5	45	43,5	40	37,5	35	-	-	-	-
ENR 40-200 Ø190	53	52,5	52,5	52	51,5	50	48	45	42,5	40	-	-	-
ENR 40-200 Ø200	58	58	57,5	57	57	56,5	55	52,5	50	47	44	-	-
ENR 40-200 Ø207	63	63	62,5	62,5	62	61,5	60	58	55	53	50	48	-
ENR 40-200 Ø214	68	68	67,5	67,5	67	66,5	65	63	60	58	56	54	52

ENR 2 Poles: 40-250 Version

Pump type ENR Three Phase	Q=Capacity											
	m ³ /h 0	5	10	15	20	25	30	32,5	35	37	39	42
	l/min 0	83,3	167	250	333	417	500	542	583	617	650	700
H=Total manometric head in meters												
ENR 40-250 Ø215	60,5	60	60	59	56	53	48	45	-	-	-	-
ENR 40-250 Ø225	68	67	66	65	64	60,5	56	53	50	-	-	-
ENR 40-250 Ø235	74	74	74	73	72	69	65	62	59,5	56	-	-
ENR 40-250 Ø245	82	82	82	81	80	78	74	71	69,5	65	63	-
ENR 40-250 Ø255	91	90,5	90	90	89	87	84	81	79,5	76	74	70

SELECTION CHART

50Hz

Rev. 0

ENR 2 Poles: 40-315 Version

Pump type ENR Three Phase	Q=Capacity											
	m ³ /h 0	5	10	15	20	25	29	31	33	37,5	40	42,5
	l/min 0	83,3	167	250	333	417	483	517	550	625	667	708
	H=Total manometric head in meters											
ENR 40-315 Ø270	91	91	90	90	88	78	69	-	-	-	-	-
ENR 40-315 Ø 285	105	104	103	102	100	92	84	79	-	-	-	-
ENR 40-345 Ø295	115	114	113	112	110	105	99	92	88	-	-	-
ENR 40-315 Ø305	126	125	123	122	120	118	110	107	100	91	-	-
ENR 40-315 Ø315	135	134	133	132	131	128	123	120	117	107	100	-
ENR 40-315 Ø325	146	146	145	144	143	141	138	132	130	122	118	110

ENR 2 Poles: 50-125 Version

Pump type ENR Three Phase	Q=Capacity										
	m ³ /h 0	5	10	20	30	35	40,5	45,5	51	58	66,5
	l/min 0	83,3	167	333	500	583	675	758	850	967	1108
	H=Total manometric head in meters										
ENR 50-125 Ø100	11,8	11,7	11,2	10	8	6	4	-	-	-	-
ENR 50-125 Ø110	14,4	14,5	14	13,9	12	10	8,2	6,8	-	-	-
ENR 50-125 Ø120	17,5	17,9	17,9	17,8	16	15	13,9	12	9,9	-	-
ENR 50-125 Ø130	21,5	21,8	21,8	21,7	20,8	20	19	18	16	13	-
ENR 50-125 Ø140	26	26	26	26	25,9	25,7	24,8	24	22,8	20	16,4

ENR 2 Poles: 50-160 Version

Pump type ENR Three Phase	Q=Capacity										
	m ³ /h 0	10	20	30	45	55	70	77	84	92	100
	l/min 0	166,7	333	500	750	917	1167	1283	1400	1533	1667
	H=Total manometric head in meters										
ENR 50-160 Ø130	21	21	20,5	20	18	16,5	12	-	-	-	-
ENR 50-160 Ø 140	26	26	25	25	23,5	22,5	18,5	16,5	-	-	-
ENR 50-160 Ø150	31	31	30	30	28	27,5	24	22,5	20	-	-
ENR 50-160 Ø160	36	36	35,5	35	34	32,5	30	28,5	26	24	-
ENR 50-160 Ø175	42	42	42	42	41	40	37,5	36	33	31,5	29

SELECTION CHART

50Hz

Rev. 0

ENR 2 Poles: 50-200 Version

Pump type ENR Three Phase	Q=Capacity											
	m³/h 0	10	20	30	50	70	74	77	83	90	92,5	95
	l/min 0	166,7	333	500	833	1167	1233	1283	1383	1500	1542	1583
	H=Total manometric head in meters											
ENR 50-200 Ø170	40	40	40	39	36	30	29	-	-	-	-	-
ENR 50-200 Ø180	46	46	45,5	45	42	36	35	33,8	-	-	-	-
ENR 50-200 Ø190	52	52	51,5	50	48	42	42	40	38	-	-	-
ENR 50-200 Ø200	57,5	57	56,5	56	54	50	48	47	44	43	-	-
ENR 50-200 Ø207	61,5	61	61	60,5	58	54	53,5	52	50	48	47	-
ENR 50-200 Ø214	65,5	65,5	65,5	65	62,5	59	58	56,5	55	53	52	52

ENR 2 Poles: 50-250 Version

Pump type ENR Three Phase	Q=Capacity									
	m³/h 0	20	30	40	50	55,0	61	68	74	79
	l/min 0	333,3	500	667	833	917	1017	1133	1233	1317
	H=Total manometric head in meters									
ENR 50-250 Ø215	60,5	60	58	56	50	48	-	-	-	-
ENR 50-250 Ø225	68	67	65	62,5	58	56	52	-	-	-
ENR 50-250 Ø235	75	74	72	70	66	63,5	59	55	-	-
ENR 50-250 Ø245	82,5	82	80	78	75	74	70	64	60	-
ENR 50-250 Ø255	90,5	90	89	87,5	84	82,5	79	75	70	66

ENR 2 Poles: 50-315 Version

Pump type ENR Three Phase	Q=Capacity											
	m³/h 0	10	20	30	40	50	70	74	84	92	99	105
	l/min 0	166,7	333	500	667	833	1167	1233	1400	1533	1650	1750
	H=Total manometric head in meters											
ENR 50-315 Ø270	98	97,5	97	96,5	95	92	70	65	-	-	-	-
ENR 50-315 Ø285	112	112	111	110,5	110	107	92	85	72	-	-	-
ENR 50-315 Ø300	125	125	125	125	125	124	113	107	92	80	-	-
ENR 50-315 Ø313	140	140	139,5	139	138	137	130	125	112	100	85	-
ENR 50-315 Ø325	152	152	151	152	151	150	145	141	132	120	105	90

SELECTION CHART

50Hz

Rev. 0

ENR 2 Poles: 65-125 Version

Pump type ENR	Q=Capacity										
	m ³ /h 0	20	30	40	50	60	80	87	102	120	140
Three Phase	l/min 0	333	500	667	833	1000	1333	1450	1700	2000	2333
H=Total manometric head in meters											
ENR 65-125 Ø110	14	13,9	13,8	13	12	10,5	7	5	-	-	-
ENR 65-125 Ø120	17,5	17	16,3	16	15	14	11,8	10	7	-	-
ENR 65-125 Ø130	21	20,7	20,5	20	19,5	18,5	16	15	12	8	-
ENR 65-125 Ø143	26,5	26,4	26,3	26,2	26	25,5	24	23	20,5	17	12

ENR 2 Poles: 65-160 Version

Pump type ENR	Q=Capacity										
	m ³ /h 0	20	40	60	80	97	107	119	130	140	150
Three Phase	l/min 0	333	667	1000	1333	1617	1783	1983	2167	2333	2500
H=Total manometric head in meters											
ENR 65-160 Ø130	20,5	20	20	18	15	10,5	-	-	-	-	-
ENR 65-160 Ø140	25	25	24,5	22,5	20	15,5	12,5	-	-	-	-
ENR 65-160 Ø150	29	29	28	27,5	25	21	17,5	15	-	-	-
ENR 65-160 Ø160	34	34	33,5	33	31,5	27,5	25	22	17,5	-	-
ENR 65-160 Ø168	38	38	37,5	37,5	35,5	32,5	30	27,5	24,5	20	-
ENR 65-160 Ø175	42	42	42	41,5	40	37,5	35,5	32,5	30	27	23

ENR 2 Poles: 65-200 Version

Pump type ENR	Q=Capacity										
	m ³ /h 0	20	40	60	80	100	110	120	130	137	143
Three Phase	l/min 0	333,3	667	1000	1333	1667	1833	2000	2167	2283	2383
H=Total manometric head in meters											
ENR 65-200 Ø170	37	36,5	35,5	33	29	24	-	-	-	-	-
ENR 65-200 Ø180	43	42	41,5	39	36	31	28	-	-	-	-
ENR 65-200 Ø190	48	48	47	46	42,5	38	35	32	-	-	-
ENR 65-200 Ø200	53	53	53	52	50	46	44	40	38	-	-
ENR 65-200 Ø207	58	58	57	56	54	52	49	46	43	41	-
ENR 65-200 Ø214	62	62	62	61	60	57	55	52	49	46,5	44

SELECTION CHART

50Hz

Rev. 0

ENR 2 Poles: 65-250 Version

Pump type ENR Three Phase	Q=Capacity											
	m ³ /h 0	20	40	50	70	80	100	120	125	132	140	145
	l/min 0	333,3	667	833	1167	1333	1667	2000	2083	2200	2333	2417
	H=Total manometric head in meters											
ENR 65-250 Ø215	57,5	57	56	55,5	55	52,5	49	42,5	-	-	-	-
ENR 65-250 Ø225	64,5	64	64,0	63,5	62	60	57	52	50	-	-	-
ENR 65-250 Ø235	72	72	71,5	71	70	69	65,5	60	59	55	-	-
ENR 65-250 Ø245	81	80,5	80	80	79	78	75	70	68	65	64	-
ENR 65-250 Ø255	90	90	89	89	88	87	84	80	78	75	72,5	70

ENR 2 Poles: 80-160 Version

Pump type ENR Three Phase	Q=Capacity											
	m ³ /h 0	20	40	60	80	100	140	145	163	180	197	210
	l/min 0	333,3	667	1000	1333	1667	2333	2417	2717	3000	3283	3500
	H=Total manometric head in meters											
ENR 80-160 Ø130	20,3	20	20	19	17,5	17	11	-	-	-	-	-
ENR 80-160 Ø140	24	23,5	23	22,5	22,5	21,5	16	14	-	-	-	-
ENR 80-160 Ø150	28,5	27,9	27,8	27,7	27,5	26	22,5	20	17,5	-	-	-
ENR 80-160 Ø160	33	32,5	32,5	32,6	32,5	31,5	28	27	24,5	22,5	-	-
ENR 80-160 Ø168	37,7	37,5	37,5	37,5	37,5	37	34	32,5	30,2	27,5	25	-
ENR 80-160 Ø175	42,5	42,5	42,5	42,5	42	42	38,5	37,5	36,5	34,5	30	27,5

ENR 2 Poles: 80-200 Version

Pump type ENR Three Phase	Q=Capacity											
	m ³ /h 0	20	40	60	80	100	150	166	178	190	204	220
	l/min 0	333,3	667	1000	1333	1667	2500	2767	2967	3167	3400	3667
	H=Total manometric head in meters											
ENR 80-200 Ø170	35,2	35	35	34	33	31	20	-	-	-	-	-
ENR 80-200 Ø180	41	41	41	40	39	37,5	28	25	-	-	-	-
ENR 80-200 Ø190	47	47	46	45,5	45	44	35	32	29	-	-	-
ENR 80-200 Ø 200	54	54	54	53	52,5	51,5	45	41	38	35	-	-
ENR 80-200 Ø207	59	58,5	58	58	57,5	57	52	50	47	44	40	-
ENR 80-200 Ø214	65	65	65	65	64	64	59	58,5	55	53	50	45,5

SELECTION CHART

50Hz

Rev. 0

ENR 2 Poles: 80-250 Version

Pump type ENR	Q=Capacity											
	m ³ /h 0	20	40	60	80	120	140	170	179	189	198	205
Three Phase	l/min 0	333,3	667	1000	1333	2000	2333	2833	2983	3150	3300	3417
H=Total manometric head in meters												
ENR 80-250 Ø215	55,5	56	55,5	55,5	55	52	48,5	40	-	-	-	-
ENR 80-250 Ø225	64,5	64,5	64,5	64,5	64	60	56	48,5	46	-	-	-
ENR 80-250 Ø235	72,5	72,5	72	72	71,5	68	65	57	55	52	-	-
ENR 80-250 Ø245	82	81	80,5	81	80,5	78	75	68	65	62	59	-
ENR 80-250 Ø255	90	90	90	90	90	88	85	78,5	75	72	69	65,5

ENR 2 Poles: 100-160 Version

Pump type ENR	Q=Capacity							
	m ³ /h 0	100	200	280	300	320	340	375
Three Phase	l/min 0	1667	3333	4667	5000	5333	5667	6250
H=manometric head in meters								
ENR 100-160Ø183(Ø183)	23	23	19	13	-	-	-	-
ENR 100-160 Ø183(Ø173)/Ø183 (Ø167) -5°	26,5	26	22,5	17	15	-	-	-
ENR 100-160 Ø183(Ø165)/Ø183 (Ø155) -7.7°	32	31	27,5	22	20	18	-	-
ENR 100-160 Ø183(Ø158)/Ø183 (Ø142) -11.5°	35	35	32,5	28	27	25	22,5	-
ENR 100-160 Ø183(Ø151)/Ø183 (Ø129) -14.7°	40	40	50	36	35	33	31	27

ENR 2 Poles: 100-200 Version

Pump type ENR	Q=Capacity									
	m ³ /h 0	50	100	150	200	226	250	270	288	312
Three Phase	l/min 0	833,3	1667	2500	3333	3767	4167	4500	4800	5200
H=Total manometric head in meters										
ENR 100-200 Ø170	33,5	32,5	30,5	26	20	15	-	-	-	-
ENR 100-200 Ø180	38	37,5	37	34	29	24,9	21	-	-	-
ENR 100-200 Ø190	44,5	44	44	40,5	36	33	30	25,5	-	-
ENR 100-200 Ø200	50,5	50,5	50	47,5	45	41,5	39	35,5	34	-
ENR 100-200 Ø213	57	57	56,5	55	53	50	48	45,5	42,5	40

SELECTION CHART

50Hz

Rev. 0

ENR 2 Poles: 100-250 Version

Pump type ENR Three Phase	Q=Capacity									
	m ³ /h 0	50	100	150	200	262	275	285	298	312
	l/min 0	833,3	1667	2500	3333	4367	4583	4750	4967	5200
	H=Total manometric head in meters									
ENR 100-250 Ø215	55,5	55	55	52,5	46,5	37,5	-	-	-	-
ENR 100-250 Ø225	65	64,5	63,5	60,5	56	46	44	-	-	-
ENR 100-250 Ø235	71,5	71	70,5	68,5	65	55	51	50	-	-
ENR 100-250 Ø245	80	80	80	78	75	65	62	60	57	-
ENR 100-250 Ø255	89	89	88,5	86,5	84	75,5	74	71	69	66

ENR 2 Poles: 125-200 Version

Pump type ENR Three Phase	Q=Capacity									
	m ³ /h 0	100	200	300	400	450	490	540	580	650
	l/min 0	1667	3333	5000	6667	7500	8167	9000	9667	10833
	H=Total manometric head in meters									
ENR 125-200 Ø180	40,5	40	38	33	25	20	-	-	-	-
ENR 125-200 Ø190	46	45	44	40	34	29,9	25	-	-	-
ENR 125-200 Ø200	50	50	50	47,5	43	40	35	30	-	-
ENR 125-200 Ø210	56,5	56	55	55	51	48	45	42	37	-
ENR 125-200 Ø220	62	62	61	60	58	56	54	52	48	43

TYPE KEY AND CURVE SPECIFICATIONS

50Hz

Rev. 0

TYPE KEY:

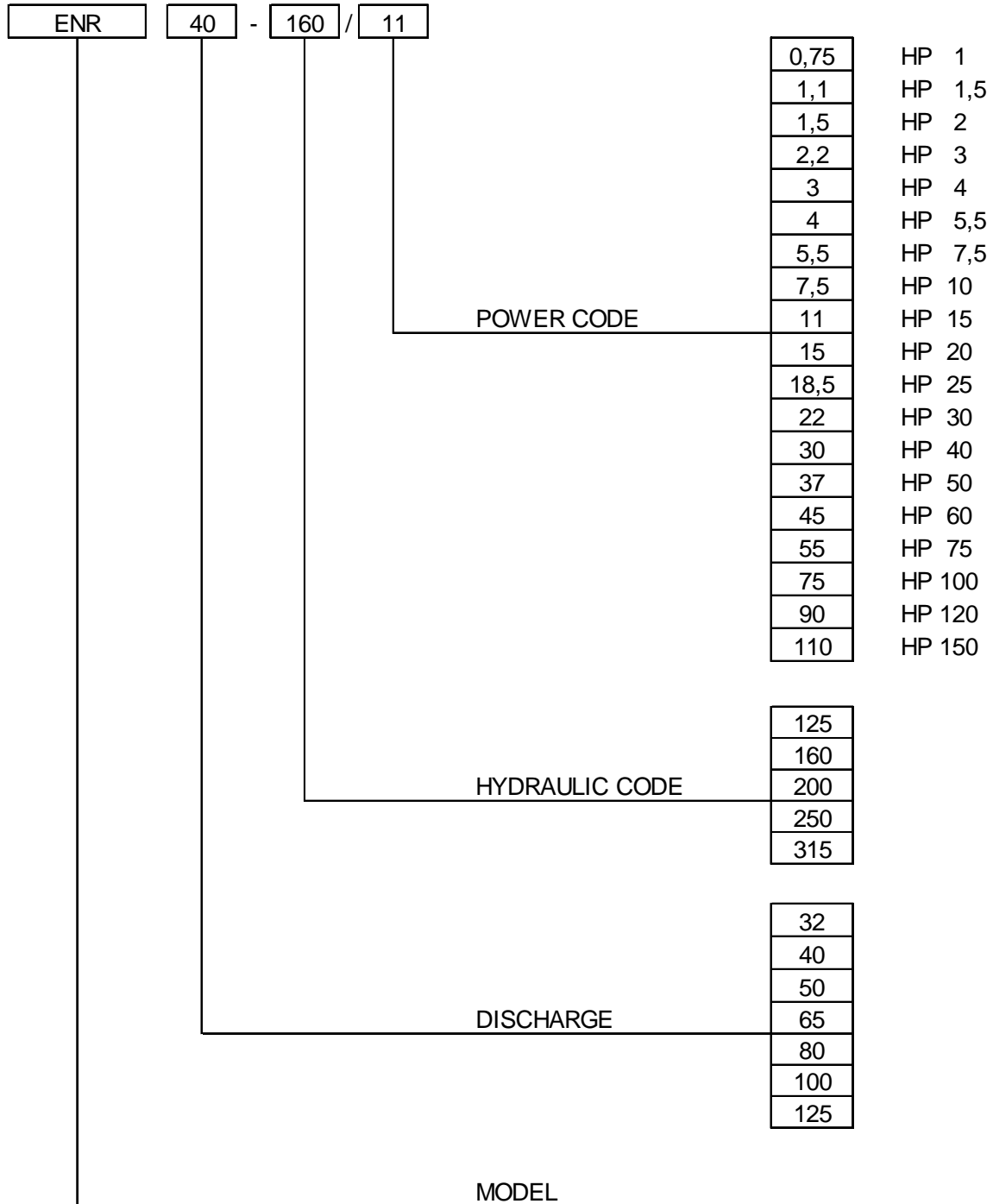

PERFORMANCE CURVE SPECIFICATIONS

The specifications below qualify the curves shown on the following pages.

Tolerances according to ISO 9906 Annex A

The curves refer to effective speed of asynchronous motors at 50 Hz

Measurements were carried out with clean water at 20°C of temperature and with a kinematic viscosity of $\nu = 1 \text{ mm}^2/\text{s}$ (1 cSt)

The NPSH curve is an average curve obtained in the same conditions of performance curves.

The continuous curves indicate the recommended working range. The dotted curve is only a guide.

In order to avoid the risk of over-heating, the pumps should not be used at a flow rate below 10% of best efficiency point.

Symbols explanation:

- Q = volume flow rate
- H = total head
- P_2 = pump power input (shaft power)
- η = pump efficiency
- NPSH = net positive suction head required by the pump
- MEI = minimum efficiency index

The minimum efficiency index (MEI) is a measure of the quality of a pump size in respect to its mean efficiency. The minimum efficiency index is based on the hydraulic efficiency and on the head at the best efficiency point.

The efficiency of a pump with trimmed impeller is usually lower than that of a pump with the full impeller diameter. The trimming of the impeller will adapt the pump to a fixed duty point, leading to reduced energy consumption. The minimum efficiency index (MEI) is based on the full impeller diameter.

The operation of these water pumps with variable duty points may be more efficient and economic when controlled, for example, by the use of a variable speed drive that matches the pump duty to the system.

MEI = 0.4 for ESOB 2900 rpm

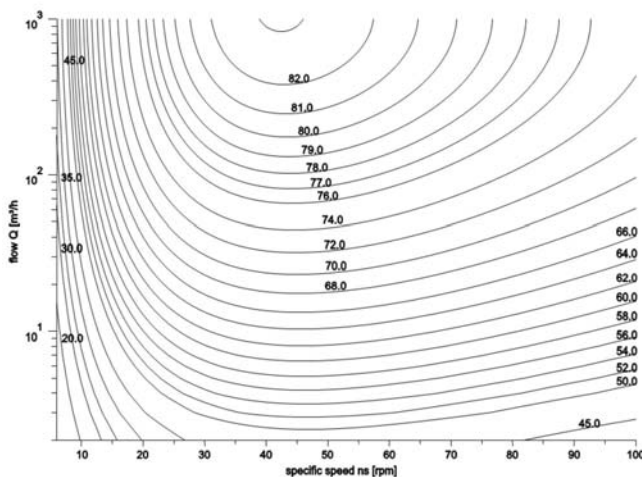

MEI = 0.7 for ESOB 2900rpm

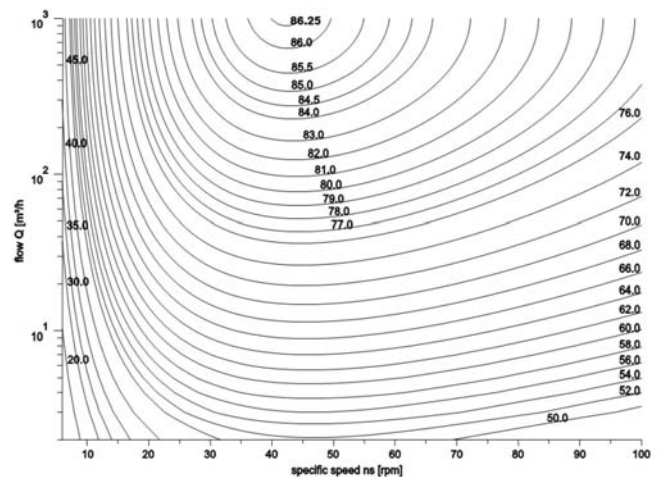

ENR 32-125 MEI > 0.40

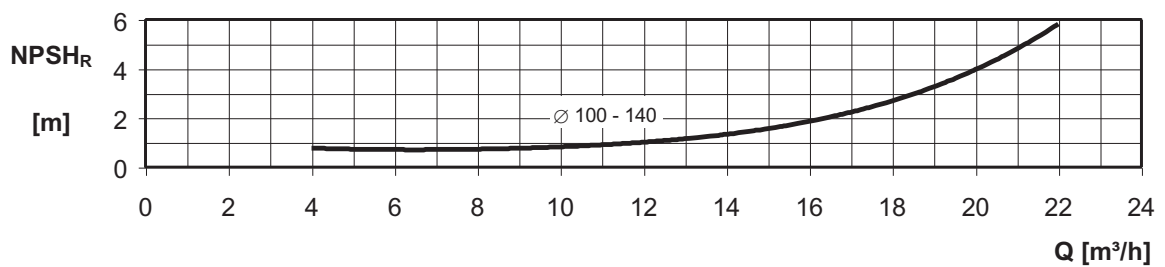
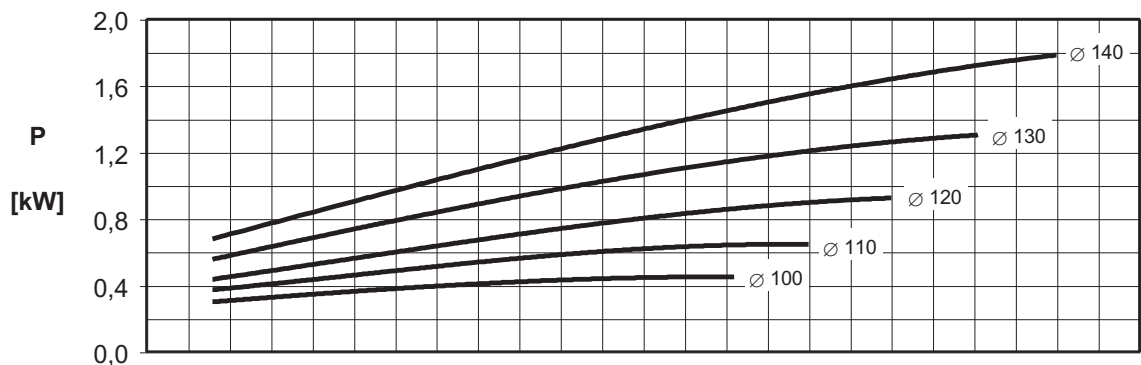
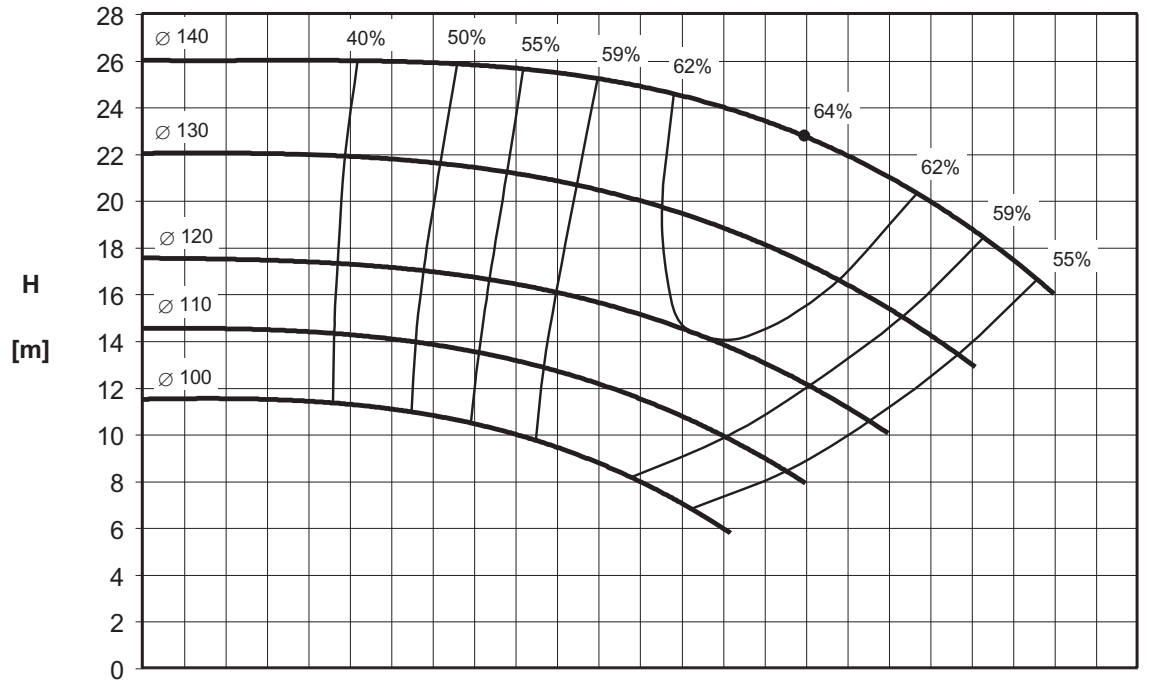

Rotation speed $\approx 2900 \text{ min}^{-1}$
 Test standard: ISO 9906 – Annex A

ENR 32-160A MEI > 0.40

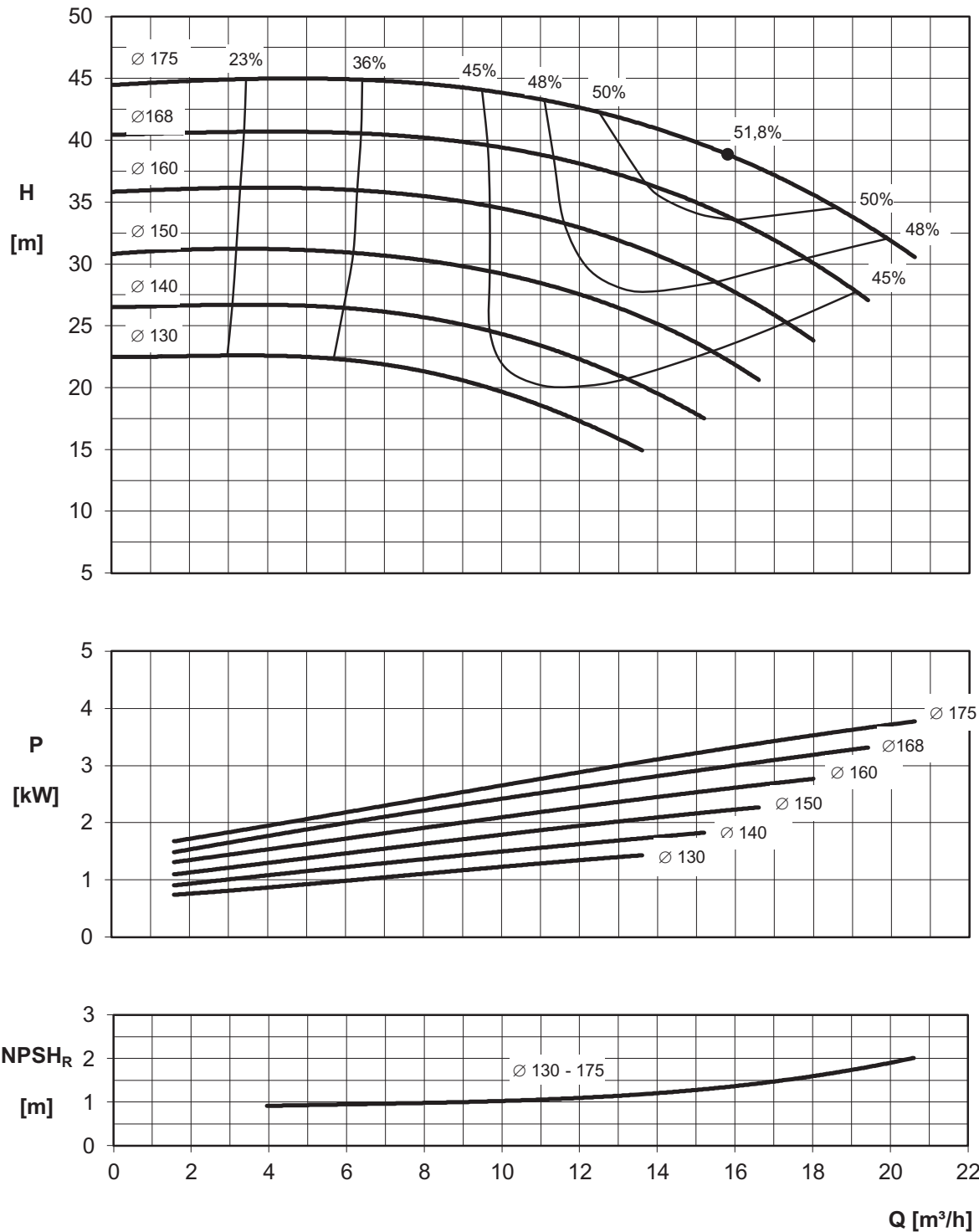

Rotation speed $\approx 2900 \text{ min}^{-1}$
 Test standard: ISO 9906 – Annex A

ENR 32-160B MEI > 0.40

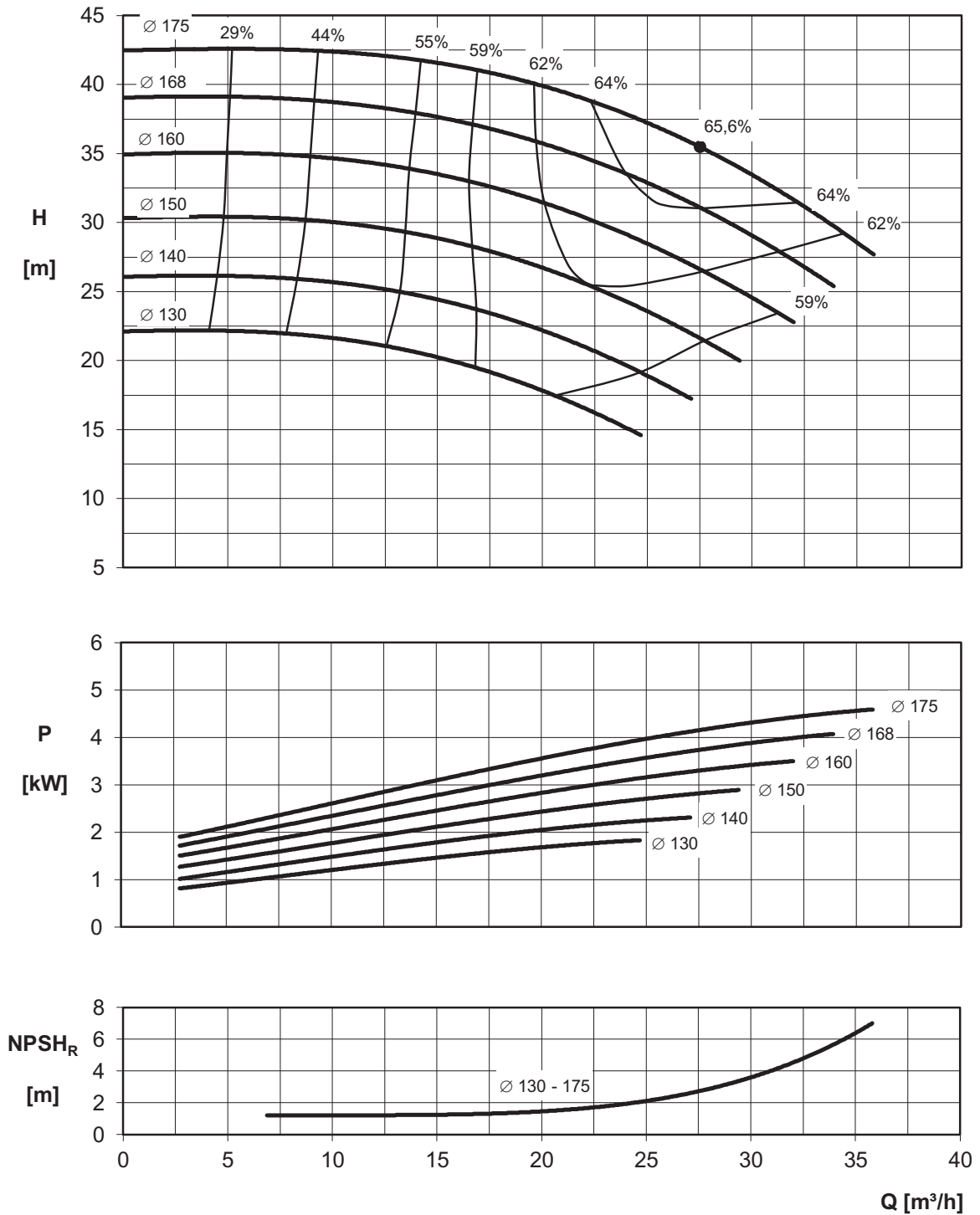

Rotation speed $\approx 2900 \text{ min}^{-1}$
 Test standard: ISO 9906 – Annex A

ENR 32-200A MEI > 0.40

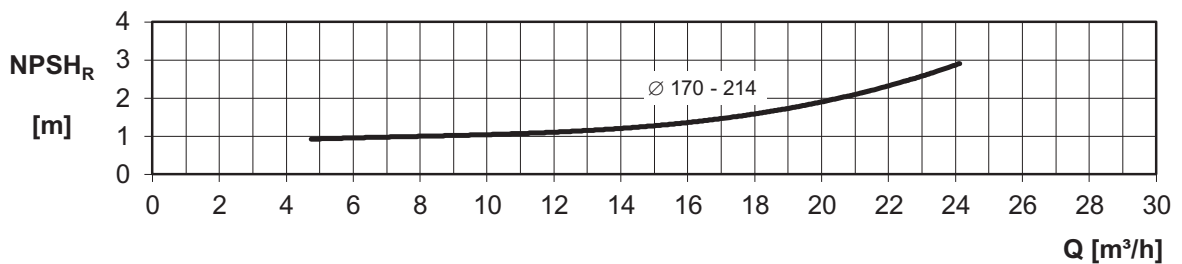
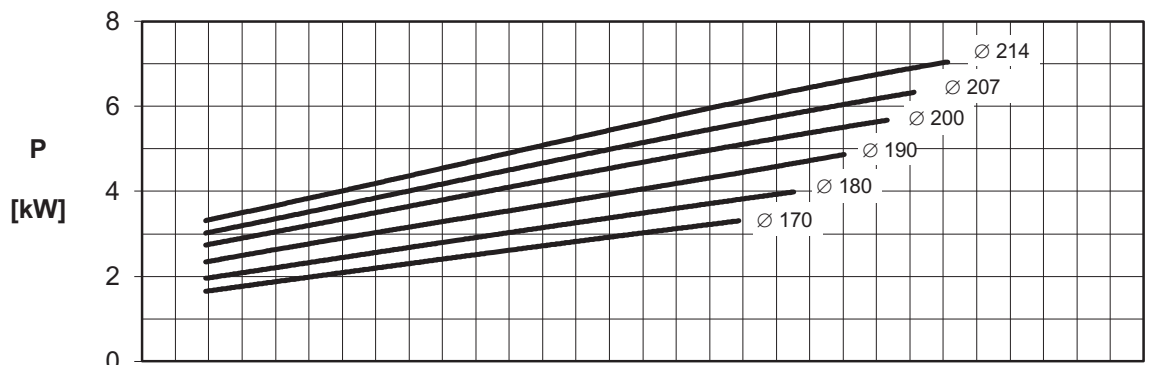
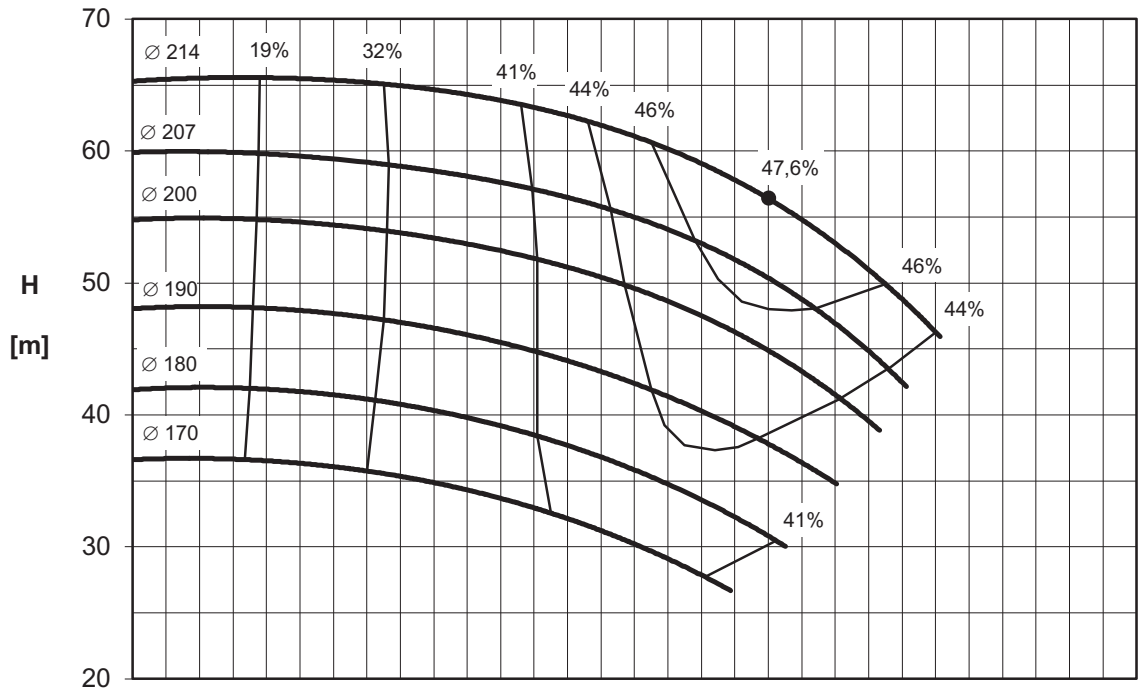

Rotation speed $\approx 2900 \text{ min}^{-1}$
 Test standard: ISO 9906 – Annex A

ENR 32-200B MEI > 0.40

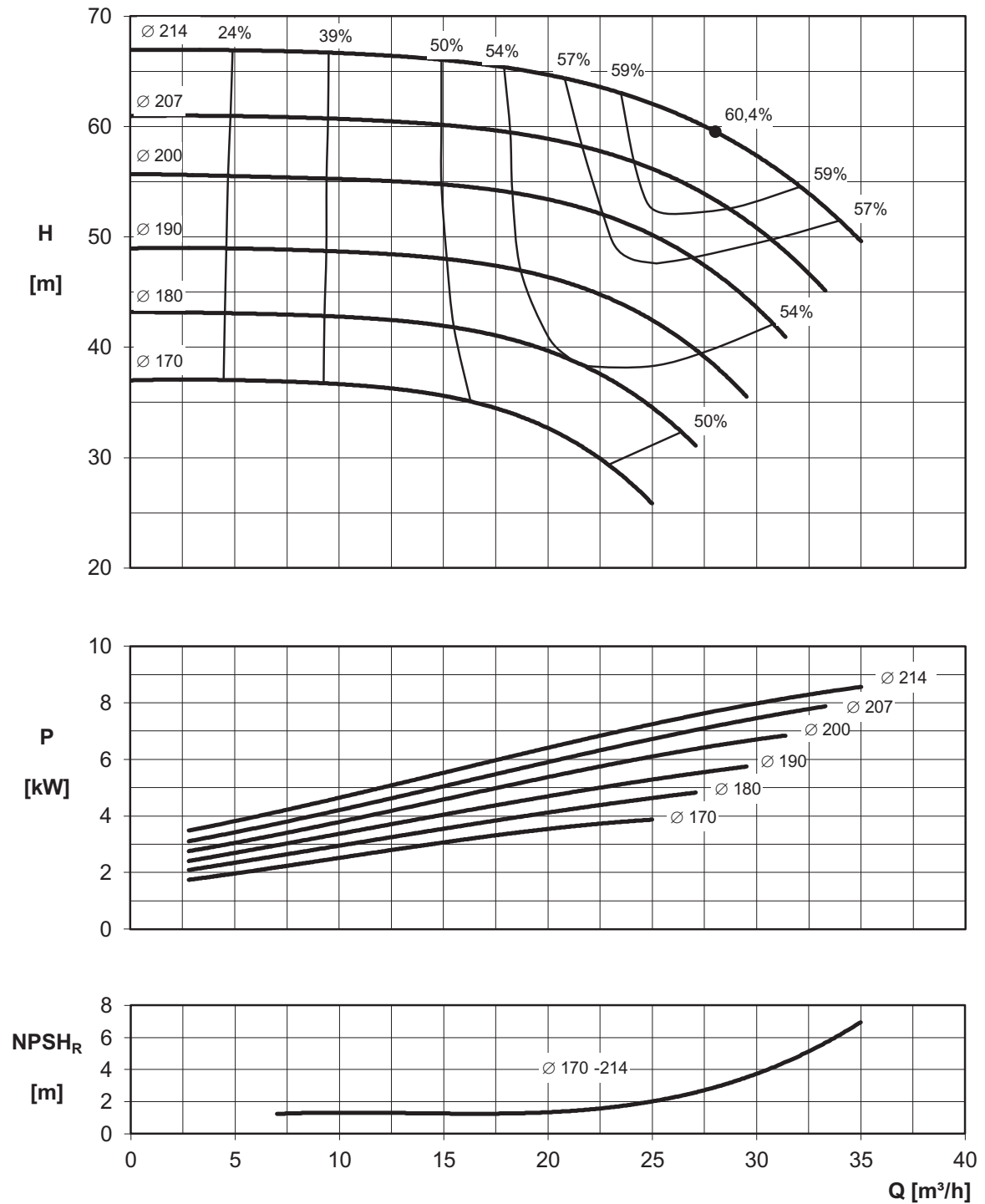

Rotation speed $\approx 2900 \text{ min}^{-1}$
 Test standard: ISO 9906 – Annex A

ENR 32-250 MEI > 0.40

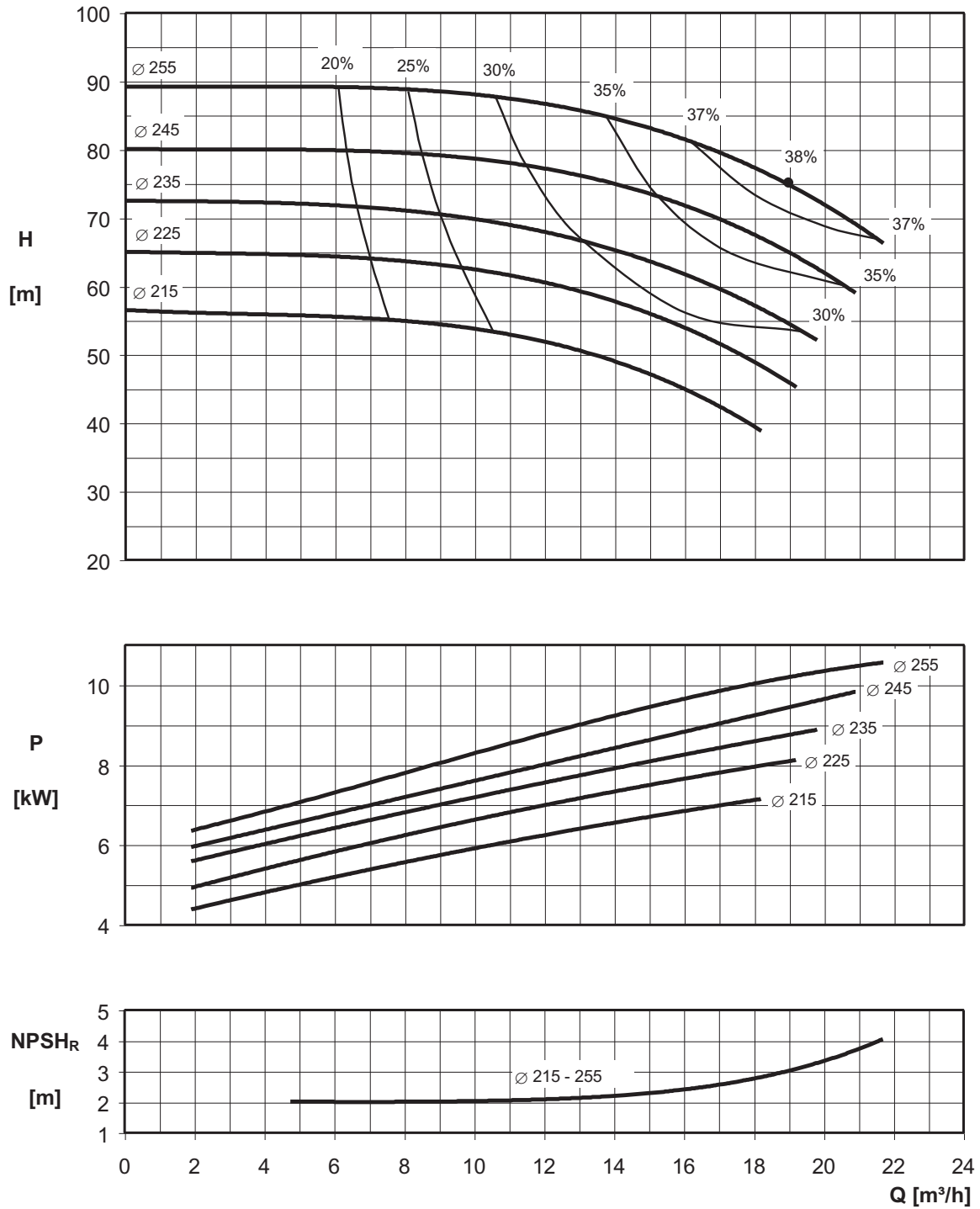

Rotation speed $\approx 2900 \text{ min}^{-1}$
 Test standard: ISO 9906 – Annex A

ENR 40-125 MEI > 0.40

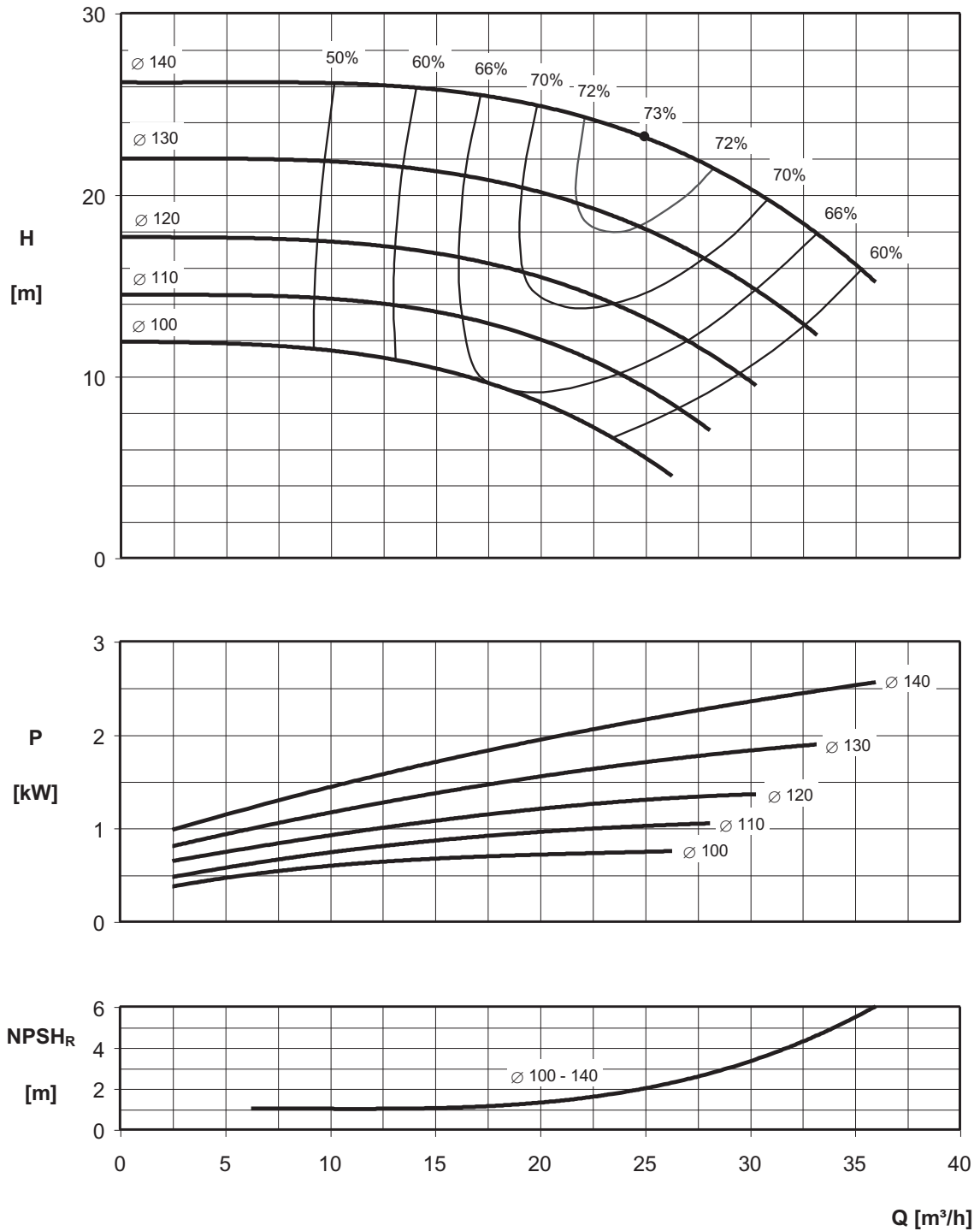

Rotation speed $\approx 2900 \text{ min}^{-1}$
 Test standard: ISO 9906 – Annex A

ENR 40-160 MEI > 0.40

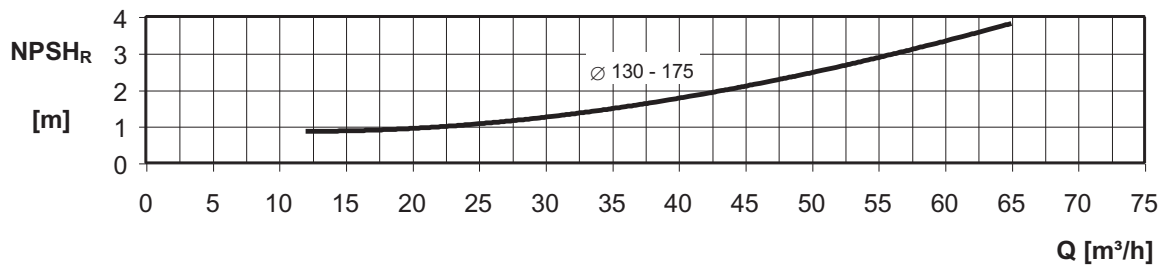
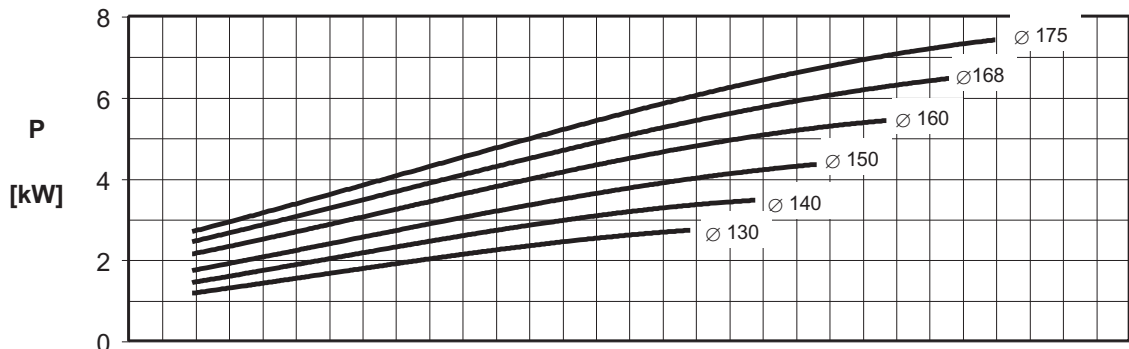
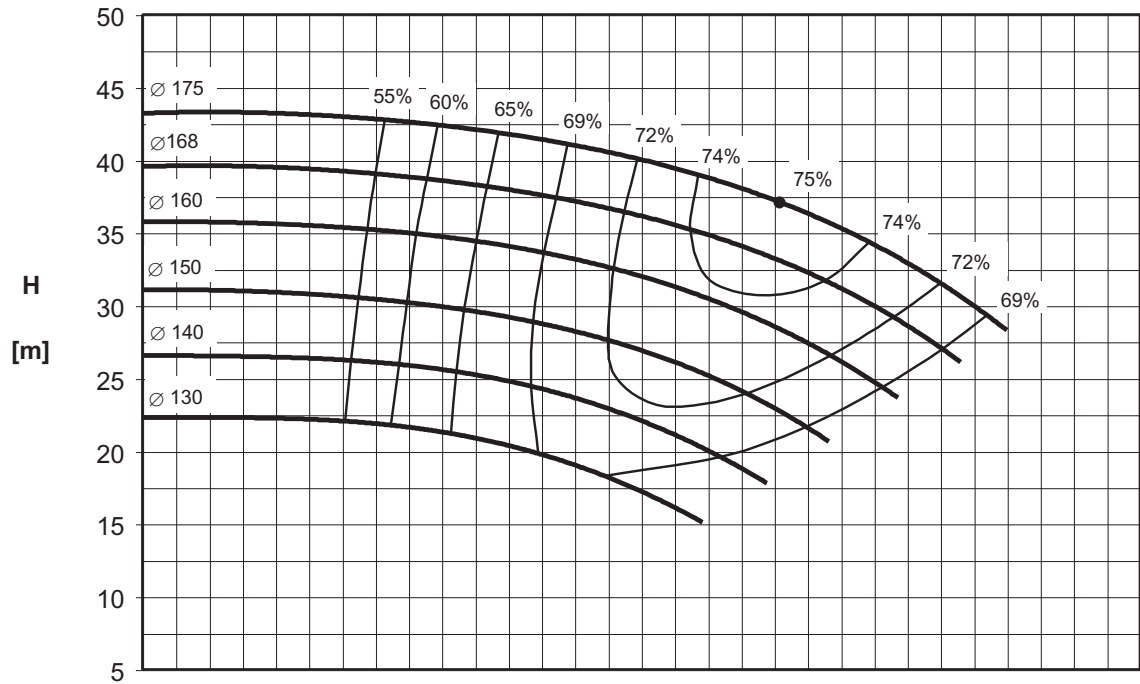

Rotation speed $\approx 2900 \text{ min}^{-1}$
 Test standard: ISO 9906 – Annex A

ENR 40-200 MEI > 0.40

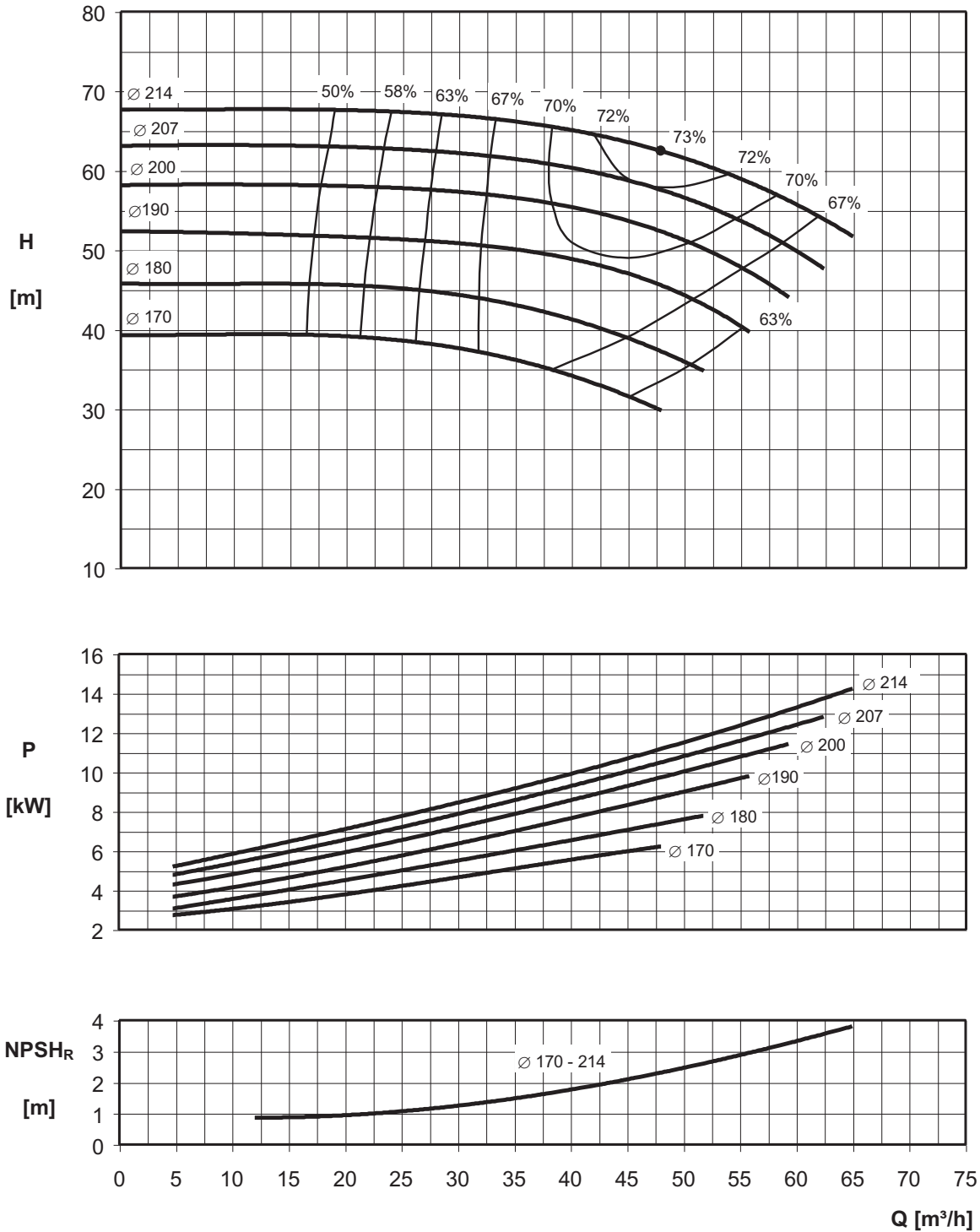

Rotation speed $\approx 2900 \text{ min}^{-1}$
 Test standard: ISO 9906 – Annex A

ENR 40-250 MEI > 0.40

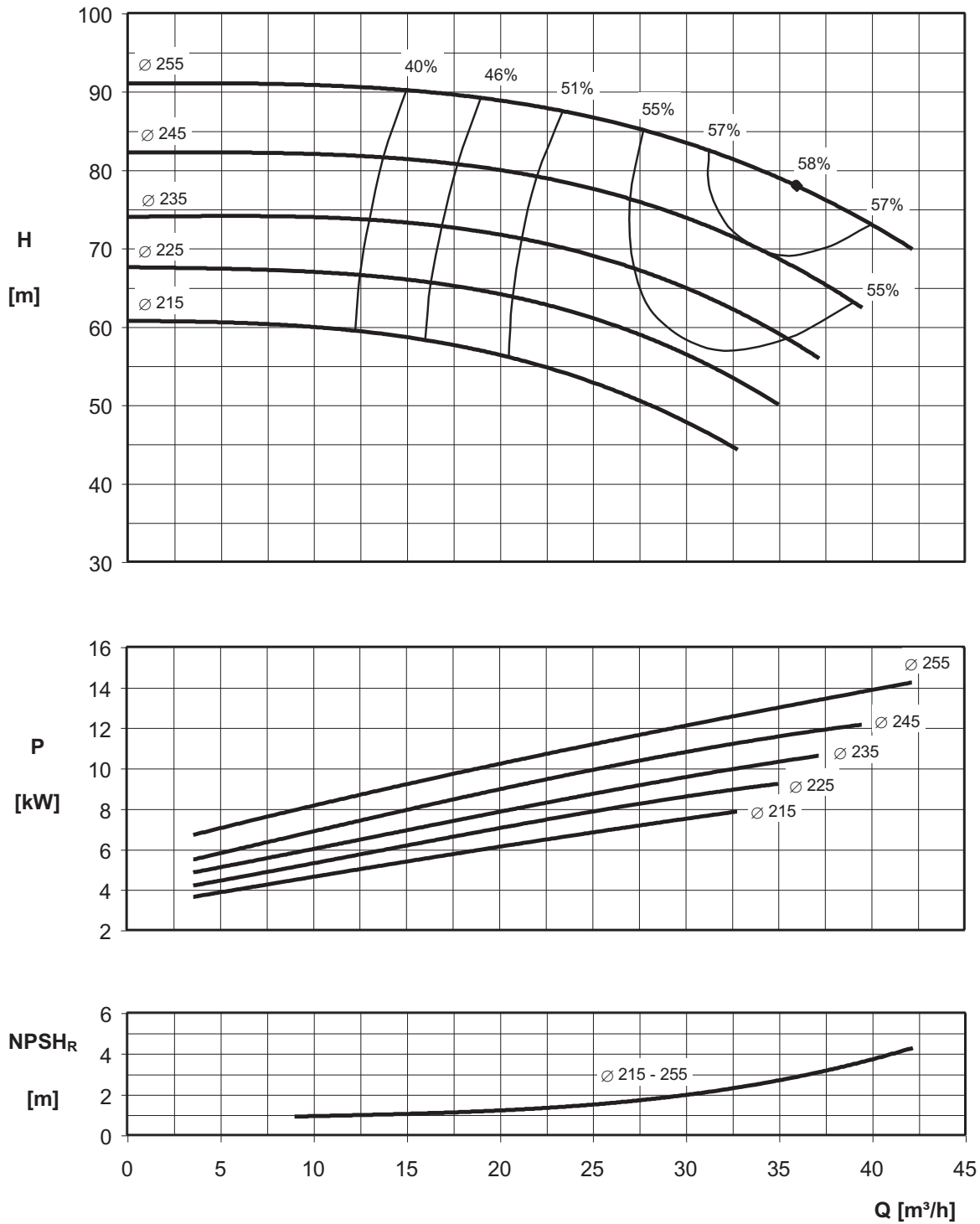

Rotation speed $\approx 2900 \text{ min}^{-1}$
 Test standard: ISO 9906 – Annex A

ENR 40-315 MEI > 0.40

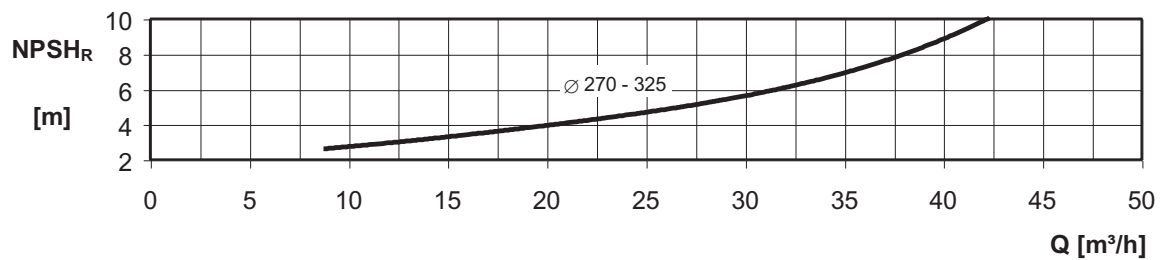
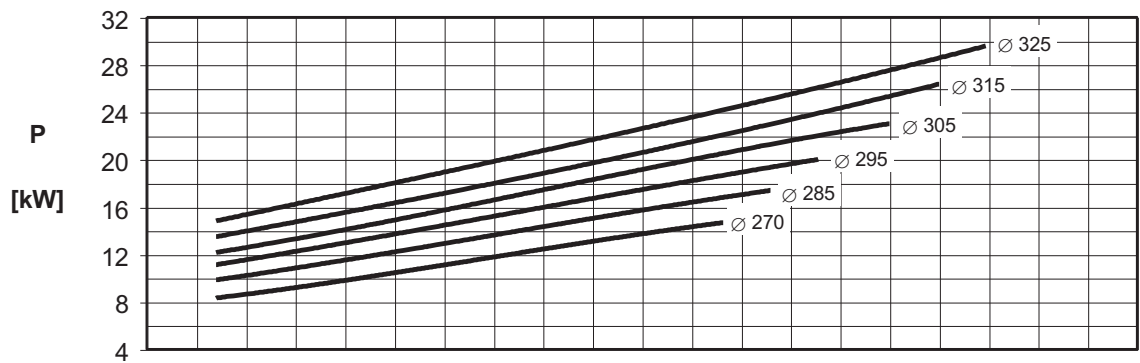
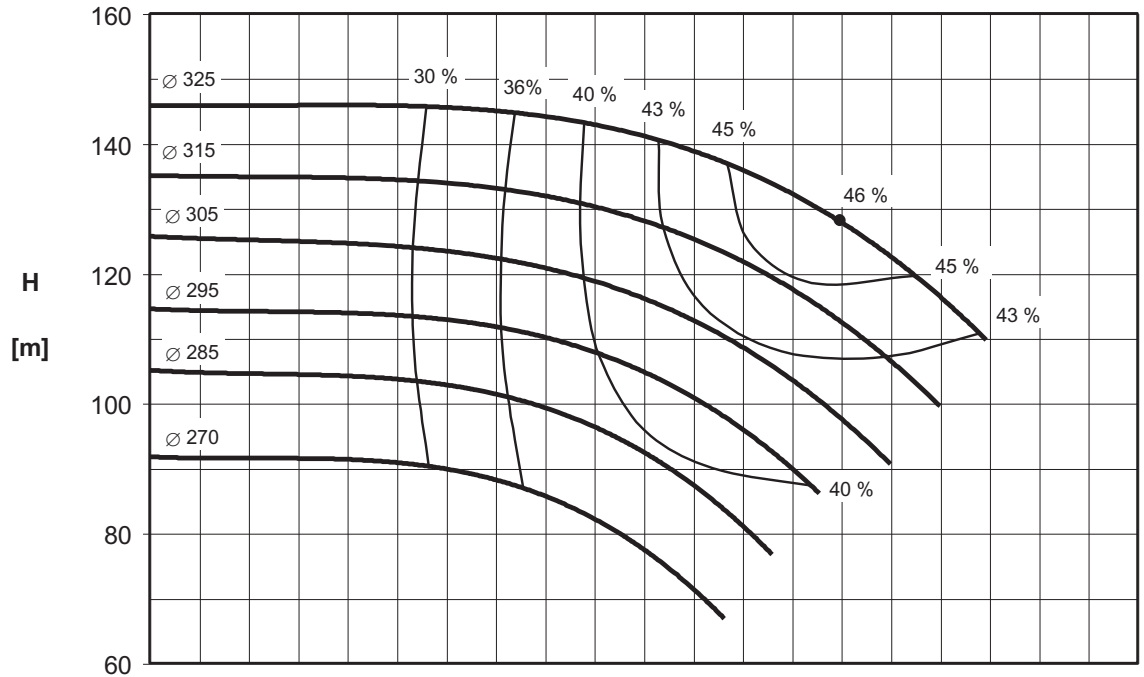

Rotation speed $\approx 2900 \text{ min}^{-1}$
 Test standard: ISO 9906 – Annex A

ENR 50-125 MEI > 0.40

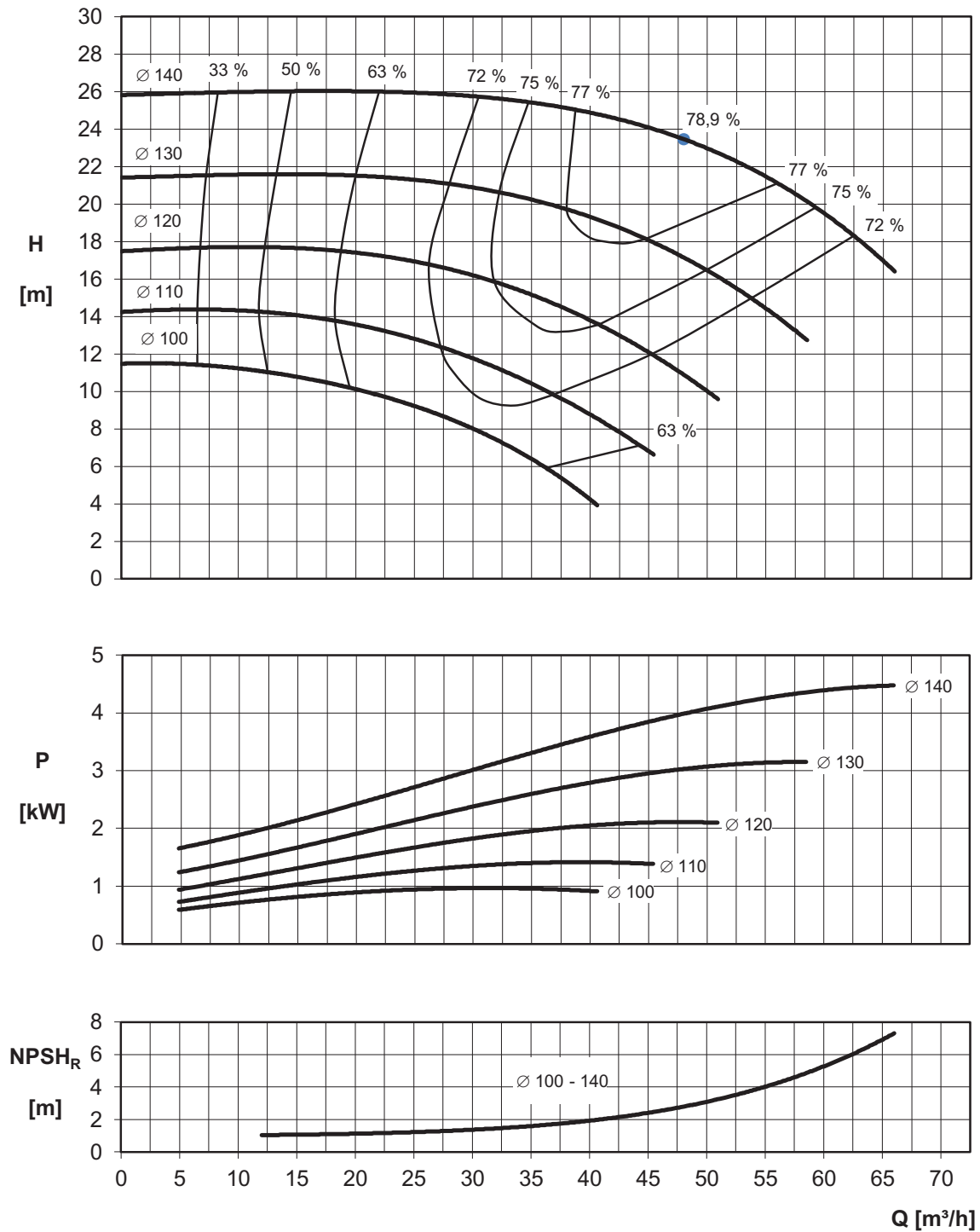

Rotation speed $\approx 2900 \text{ min}^{-1}$
 Test standard: ISO 9906 – Annex A

ENR 50-160 MEI > 0.40

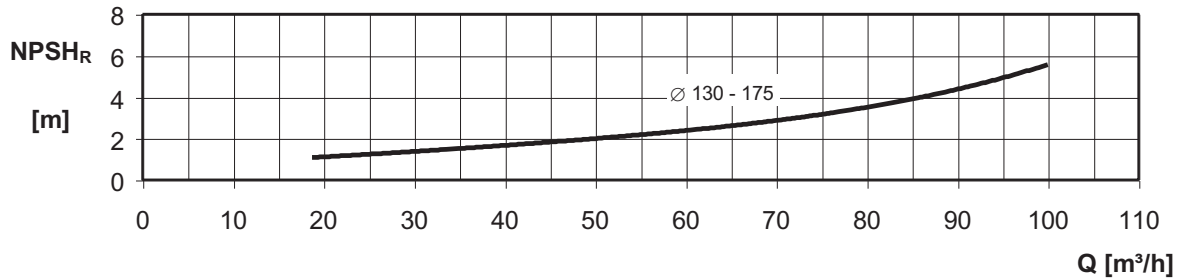
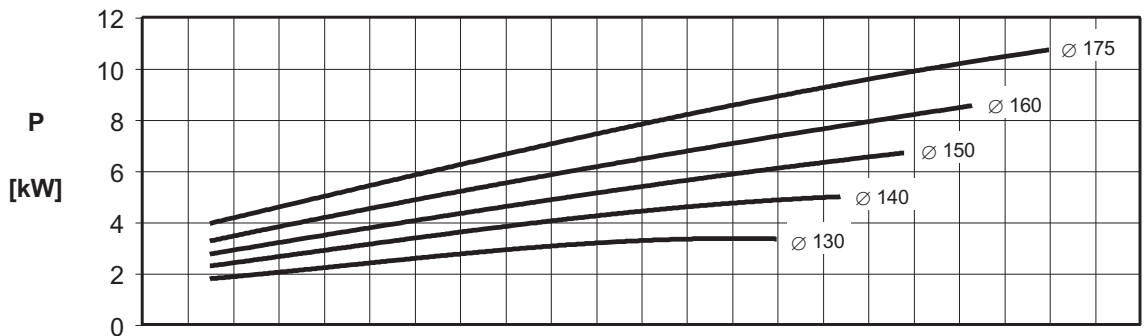
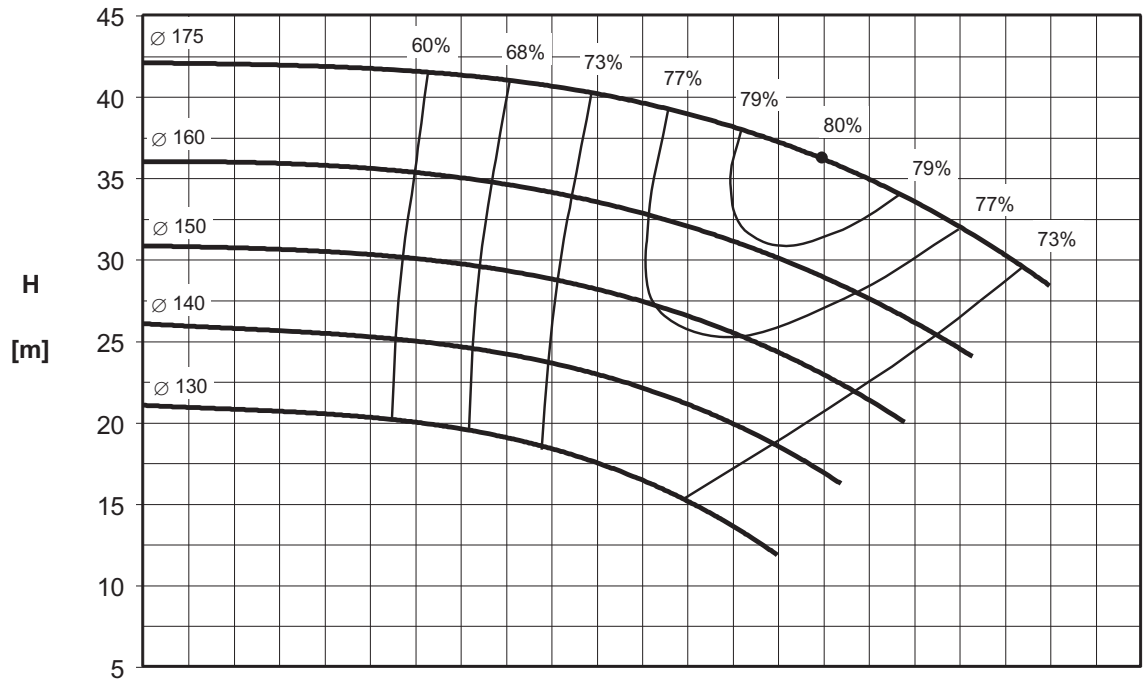

Rotation speed $\approx 2900 \text{ min}^{-1}$
 Test standard: ISO 9906 – Annex A

ENR 50-200 MEI > 0.40

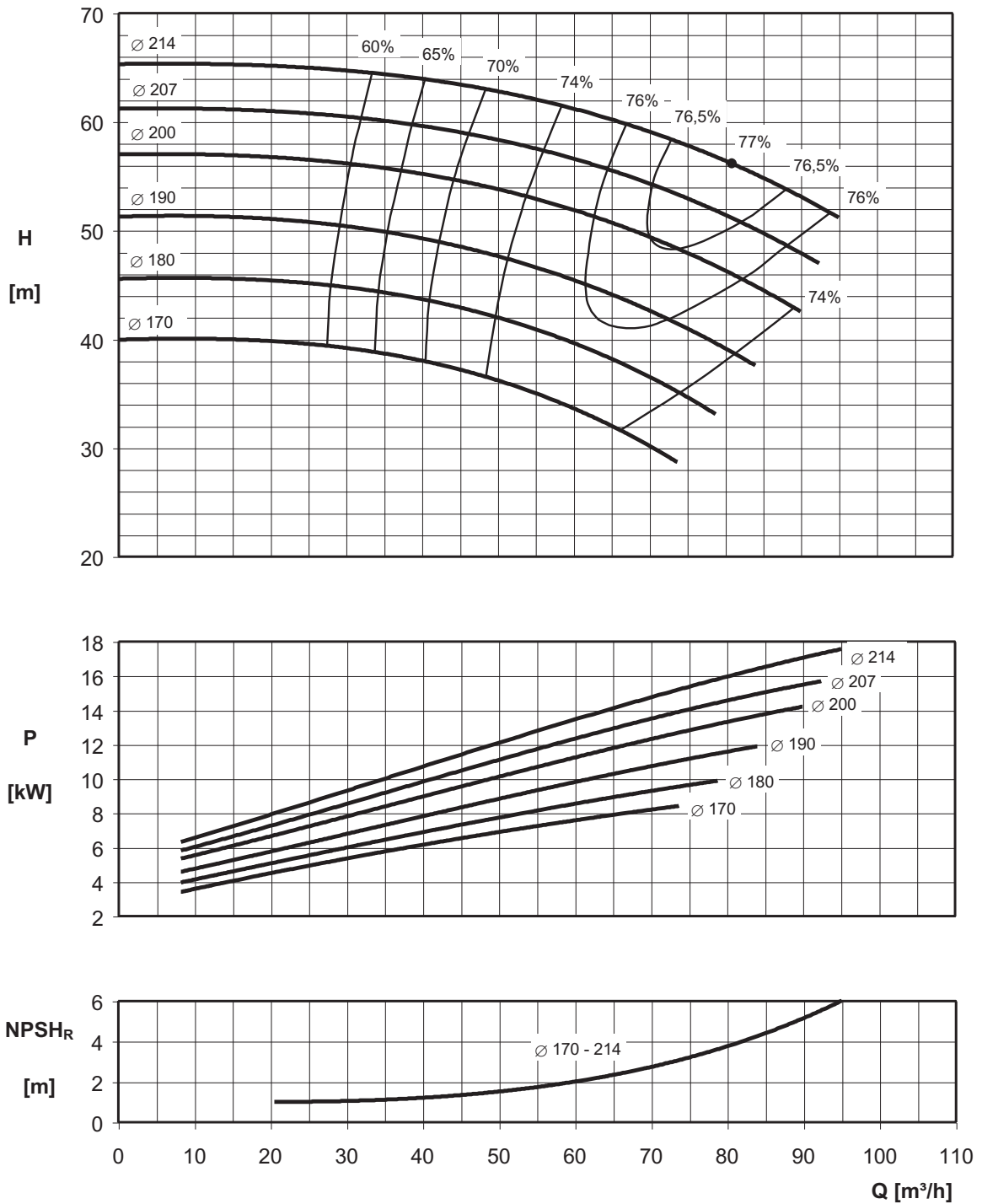

Rotation speed $\approx 2900 \text{ min}^{-1}$
 Test standard: ISO 9906 – Annex A

ENR 50-250 MEI > 0.40

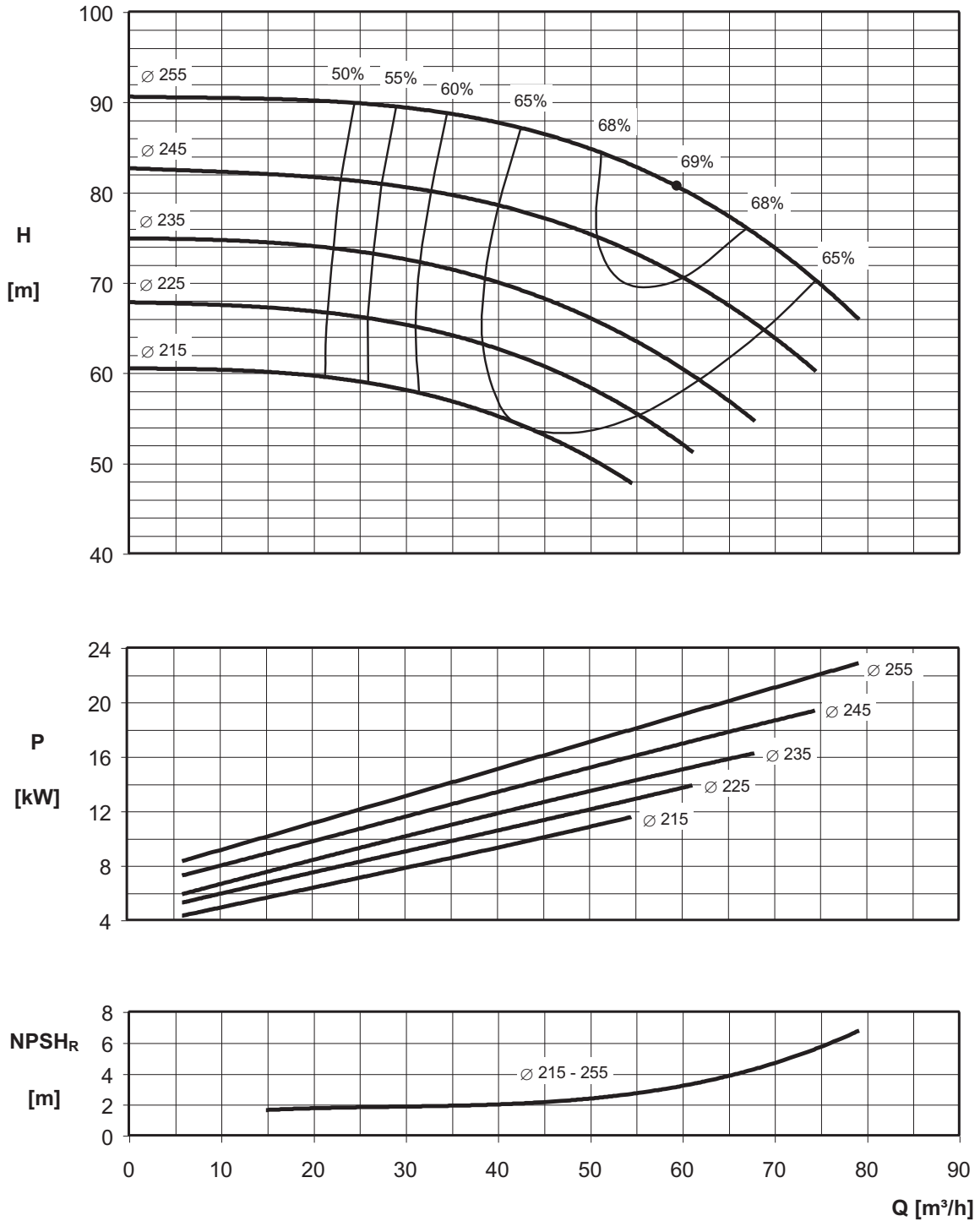

Rotation speed $\approx 2900 \text{ min}^{-1}$
 Test standard: ISO 9906 – Annex A

ENR 50-315 MEI > 0.40

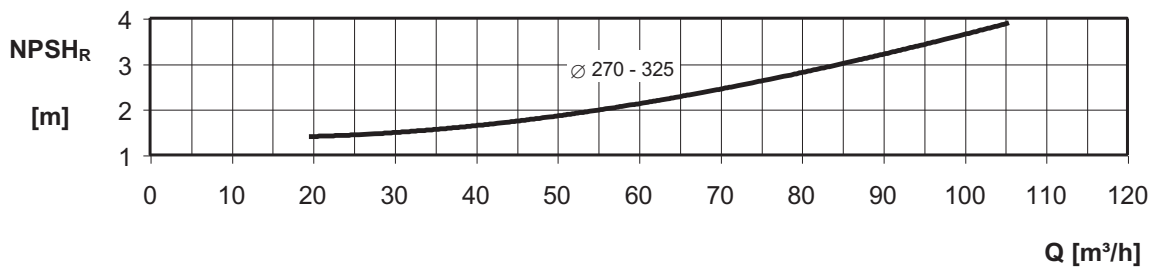
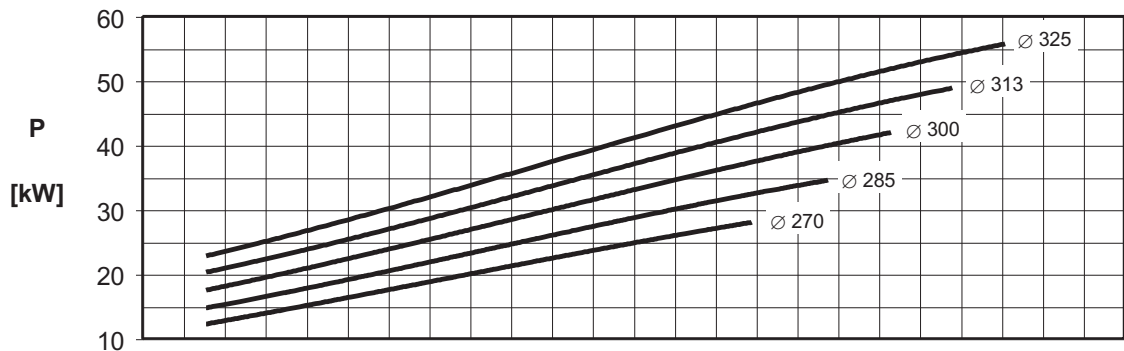
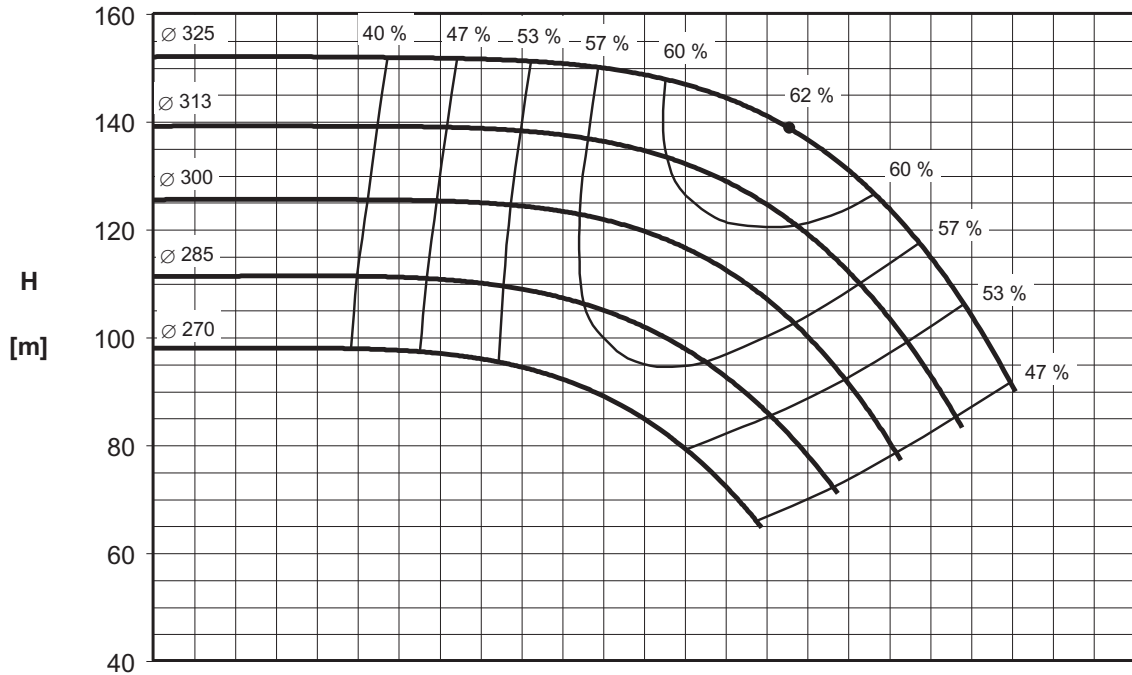

Rotation speed $\approx 2900 \text{ min}^{-1}$
 Test standard: ISO 9906 – Annex A

ENR 65-125 MEI > 0.40

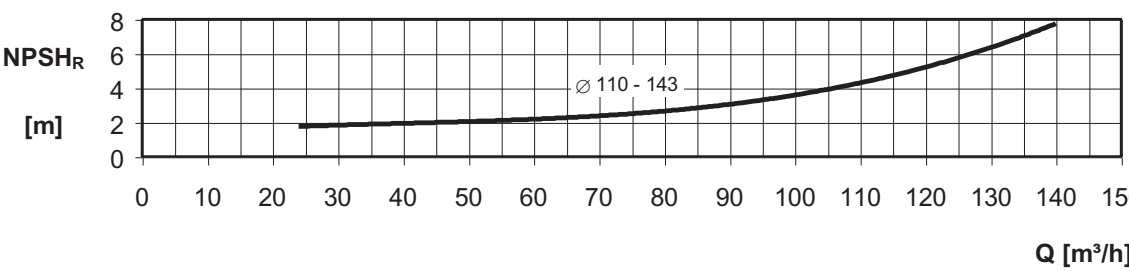
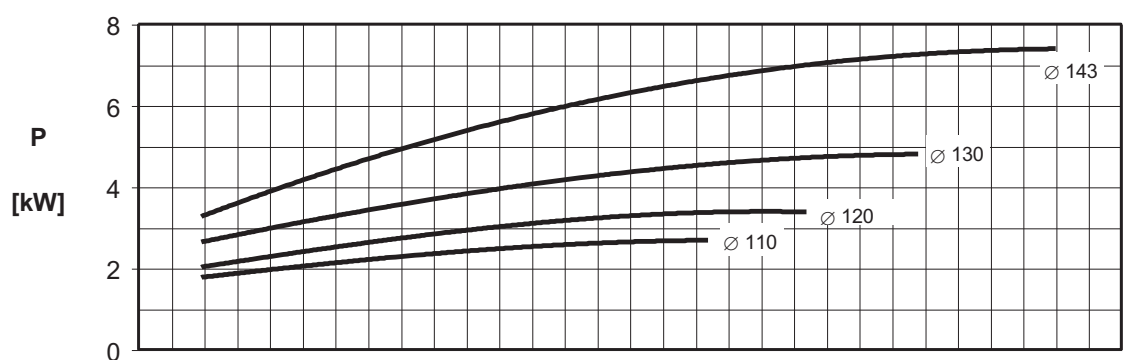
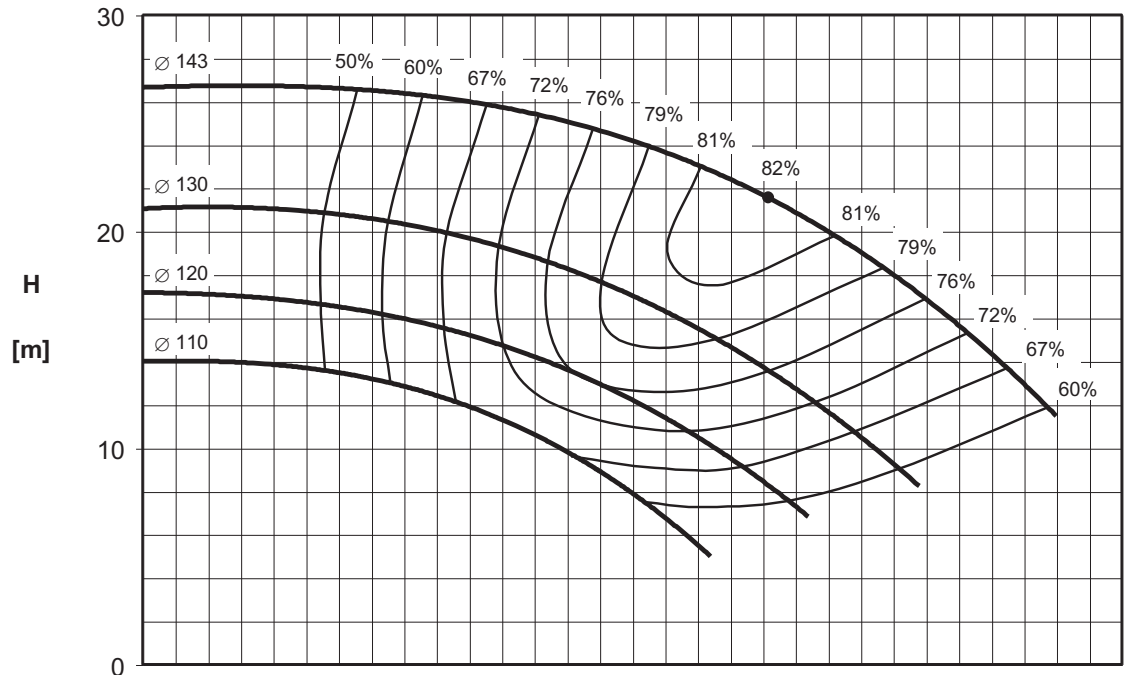

Rotation speed $\approx 2900 \text{ min}^{-1}$
 Test standard: ISO 9906 – Annex A

ENR 65-160 MEI > 0.40

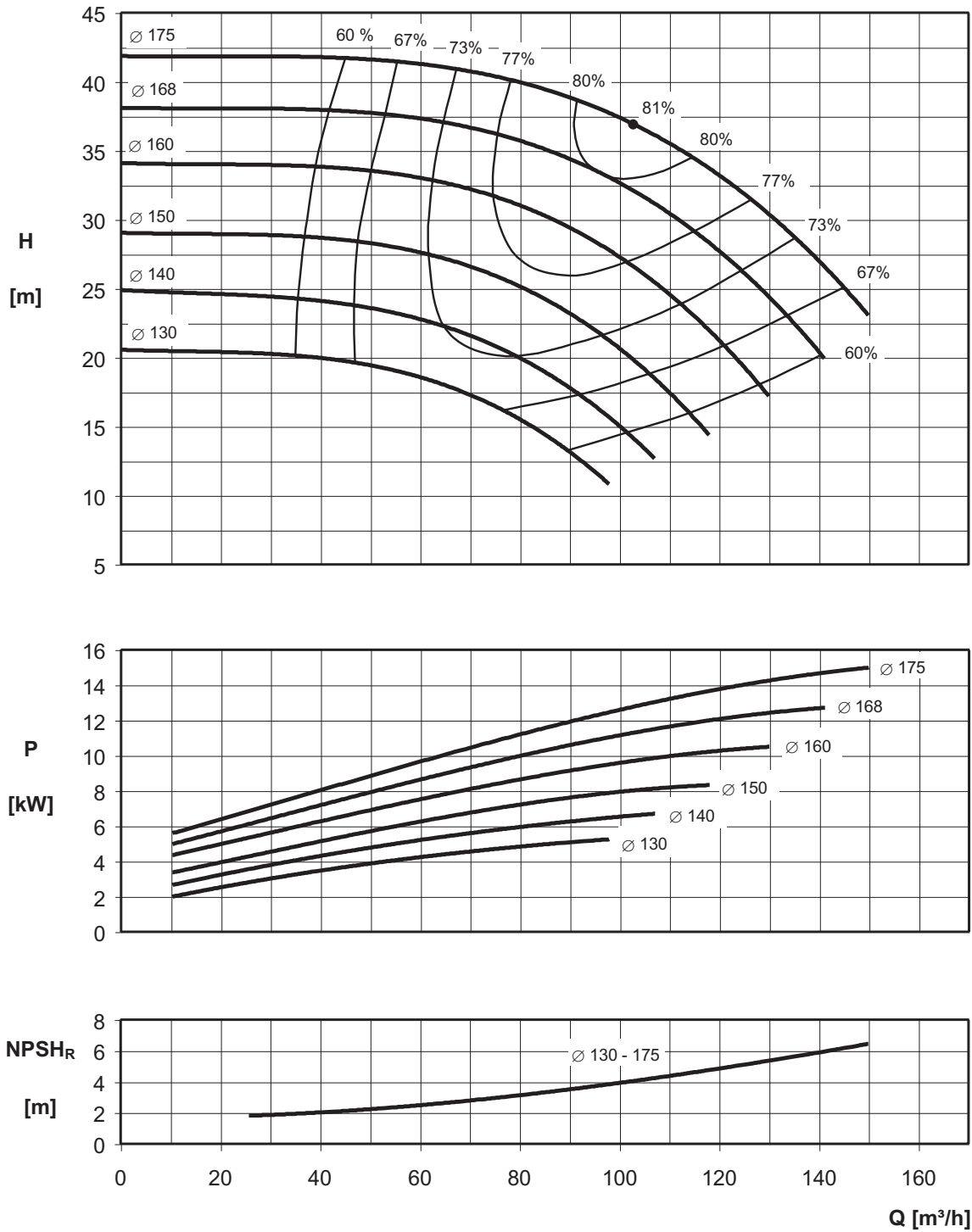

Rotation speed $\approx 2900 \text{ min}^{-1}$
 Test standard: ISO 9906 – Annex A

ENR 65-200 MEI > 0.40

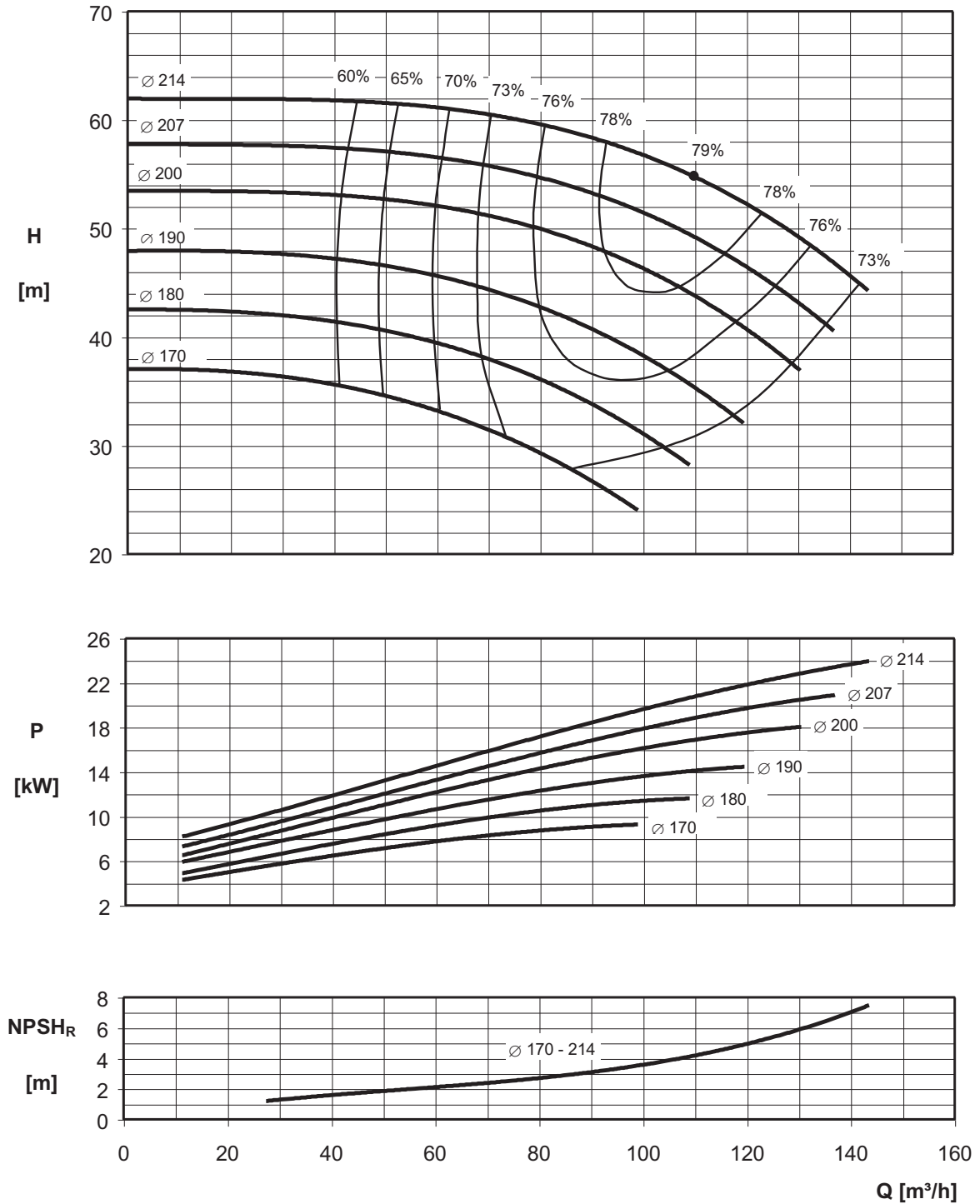

Rotation speed $\approx 2900 \text{ min}^{-1}$
 Test standard: ISO 9906 – Annex A

ENR 65-250 MEI > 0.40

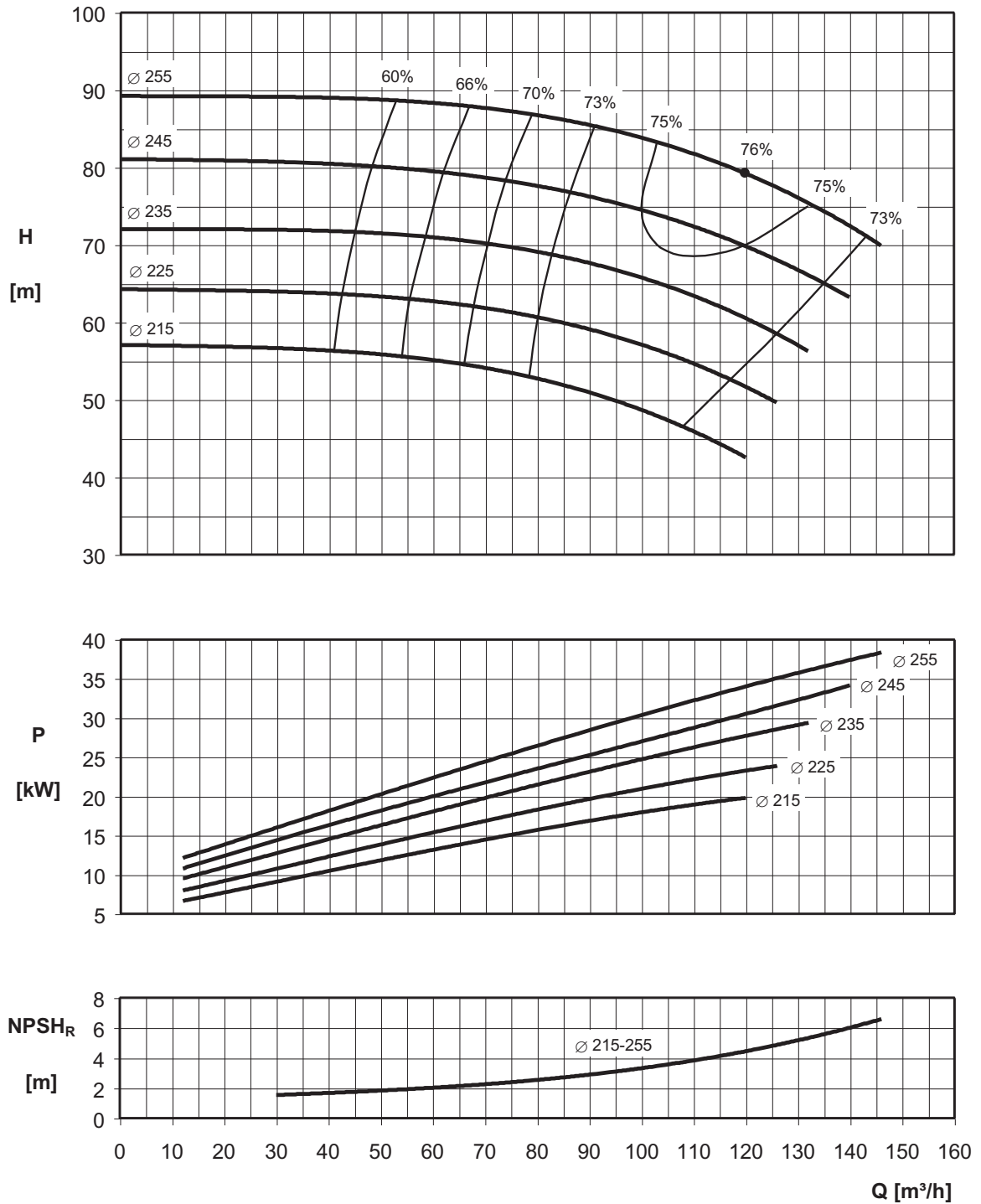

Rotation speed $\approx 2900 \text{ min}^{-1}$
 Test standard: ISO 9906 – Annex A

ENR 80-160 MEI > 0.40

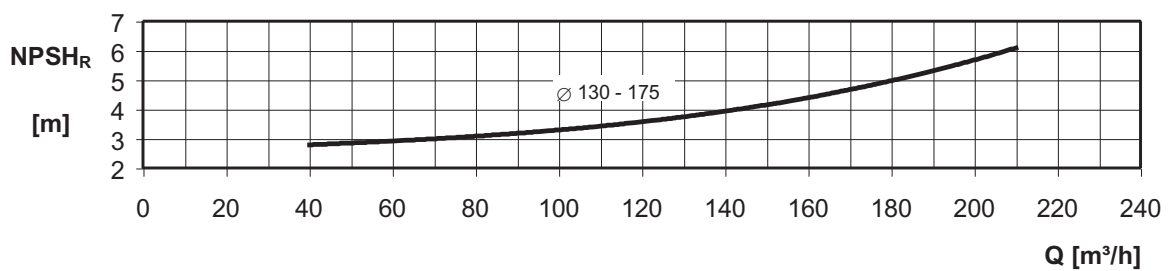
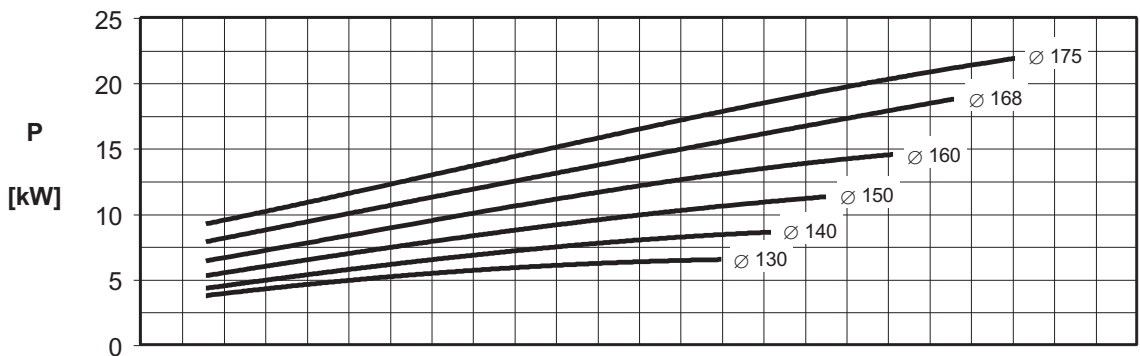
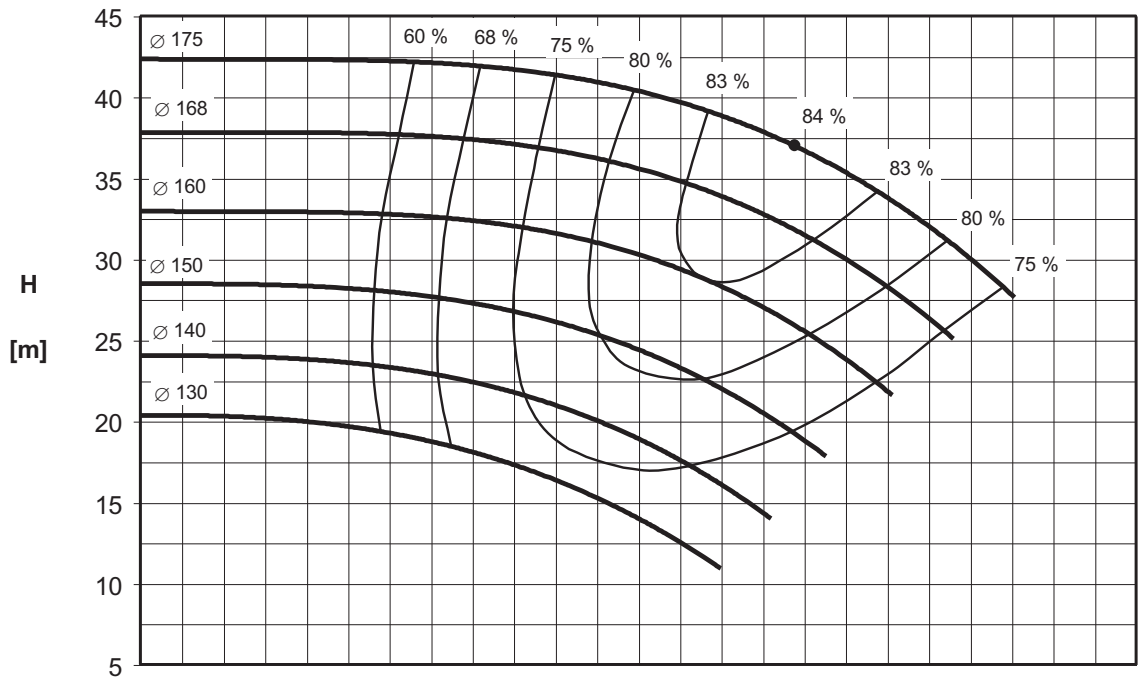

Rotation speed $\approx 2900 \text{ min}^{-1}$
 Test standard: ISO 9906 – Annex A

ENR 80-200 MEI > 0.40

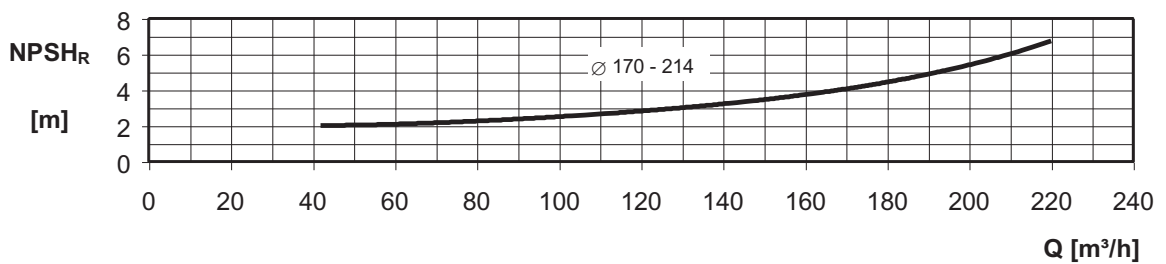
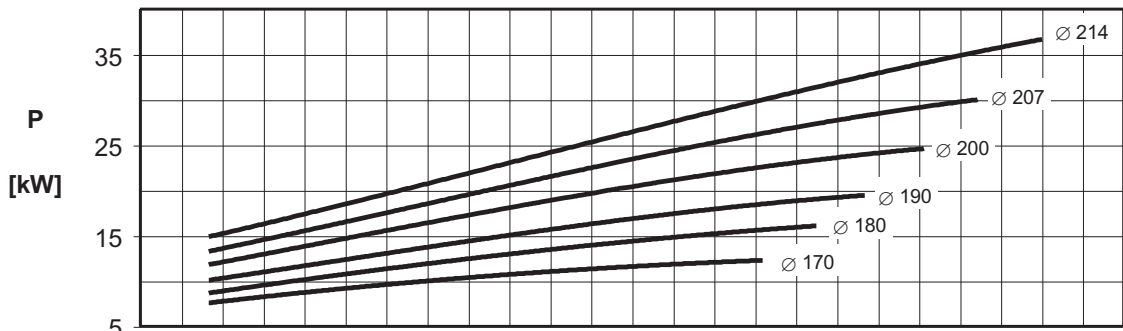
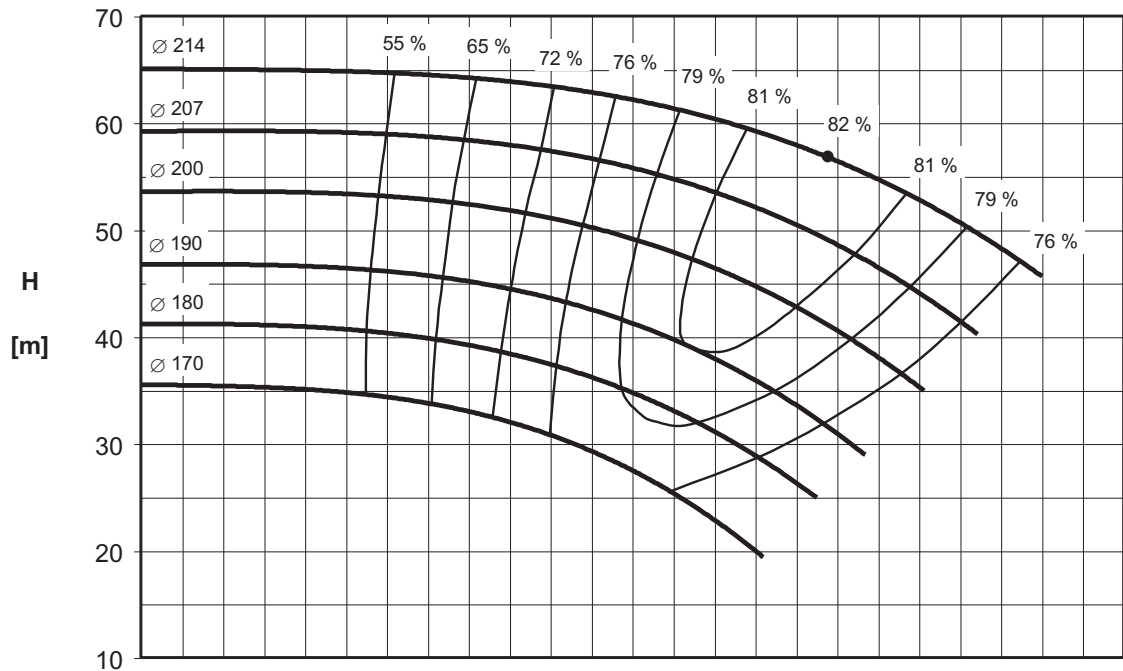

Rotation speed $\approx 2900 \text{ min}^{-1}$
 Test standard: ISO 9906 – Annex A

ENR 80-250 MEI > 0.40

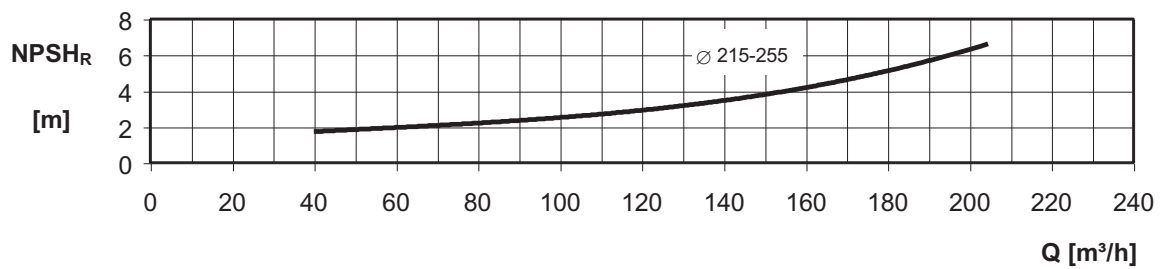
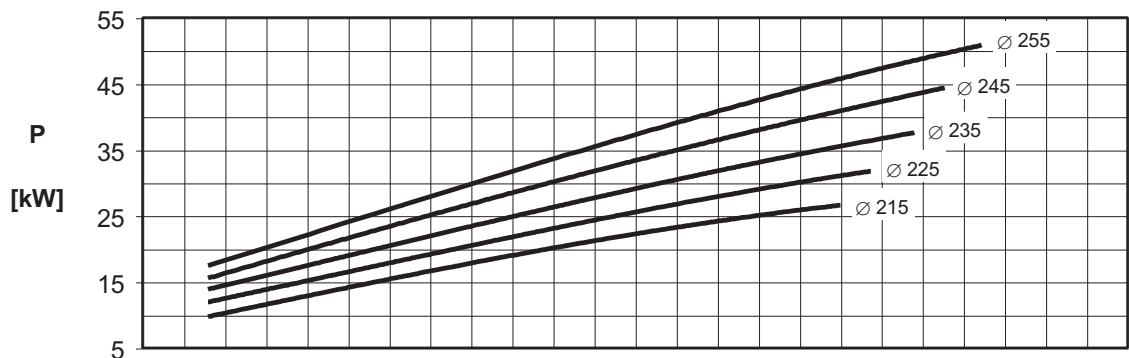
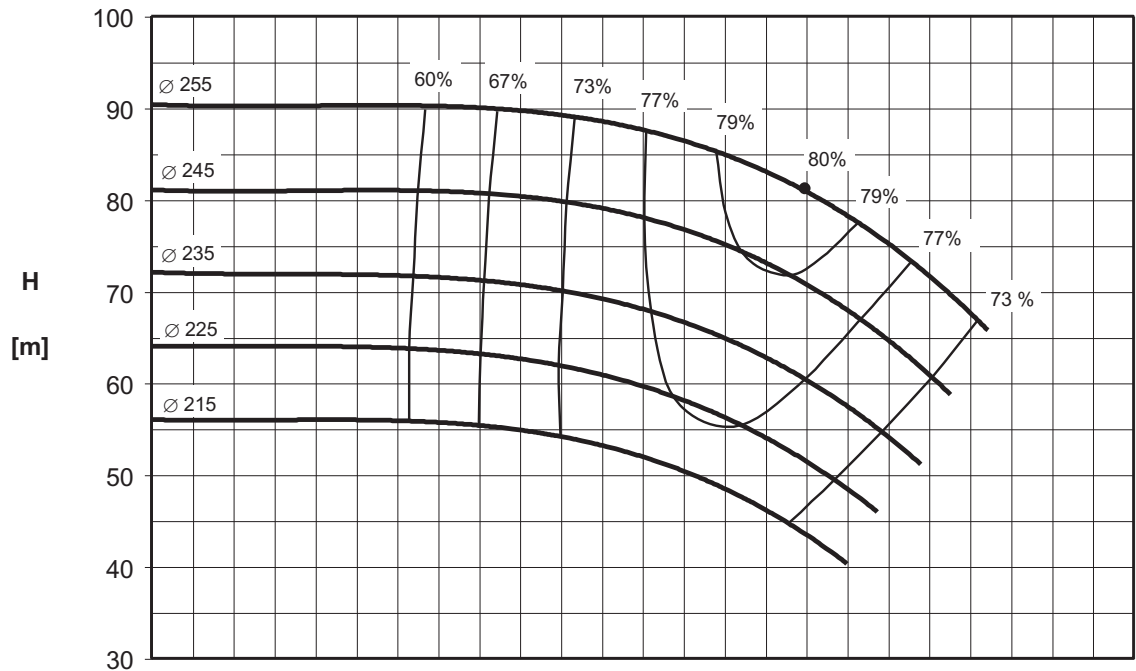

Rotation speed $\approx 2900 \text{ min}^{-1}$
 Test standard: ISO 9906 – Annex A

ENR 100-160 MEI > 0.40

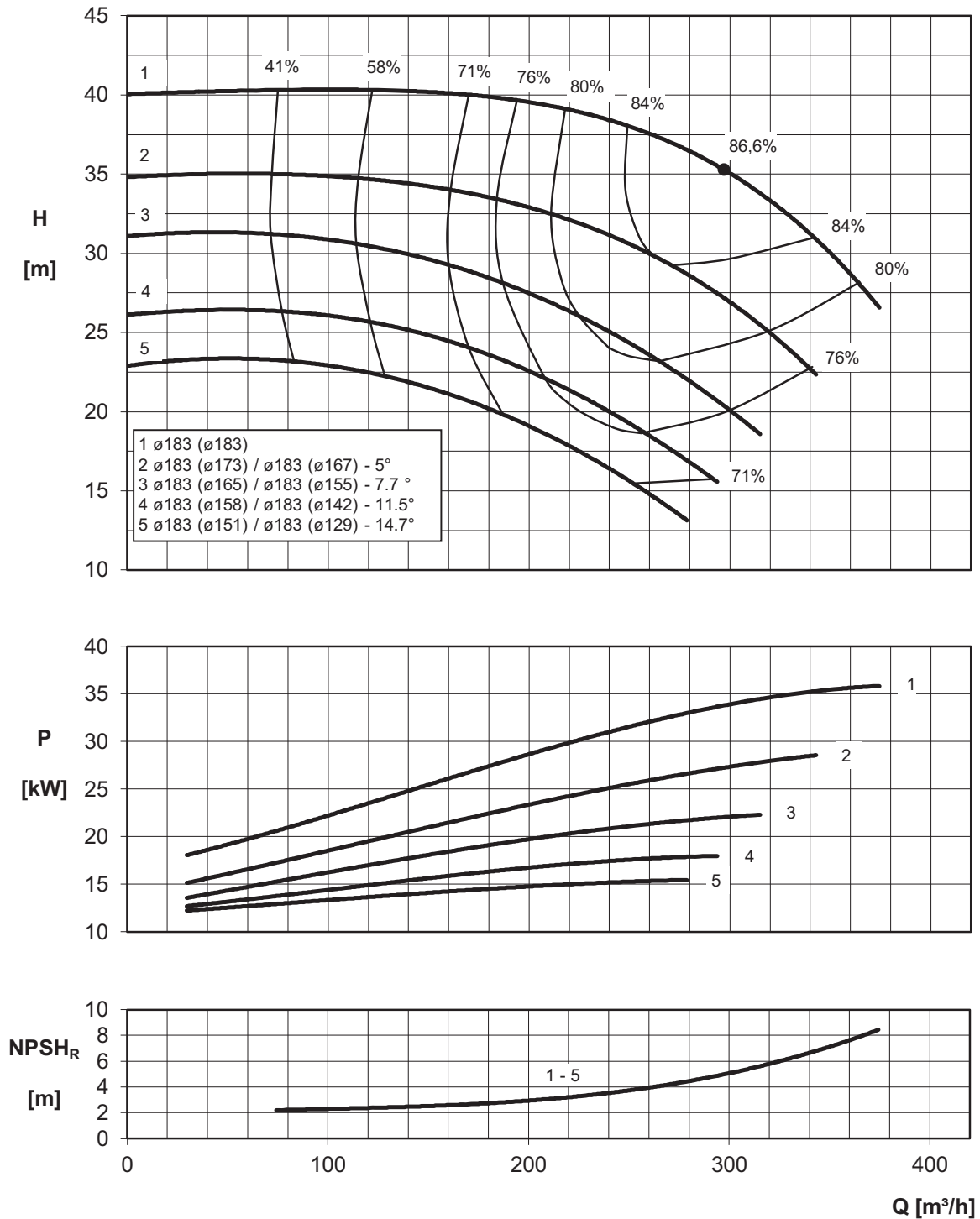

Rotation speed $\approx 2900 \text{ min}^{-1}$
 Test standard: ISO 9906 – Annex A

ENR 100-200 MEI > 0.40

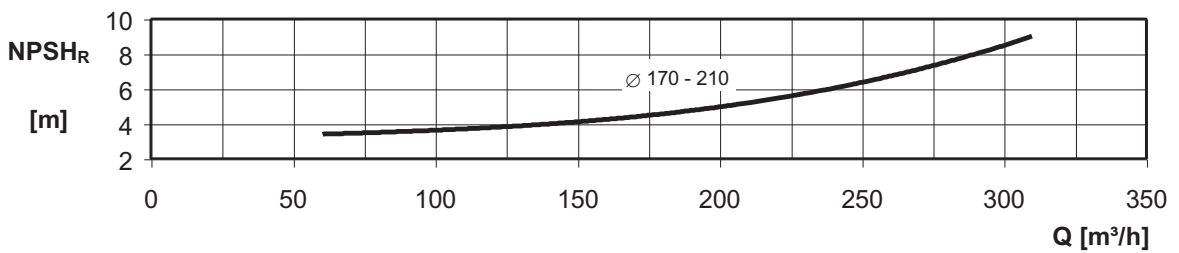
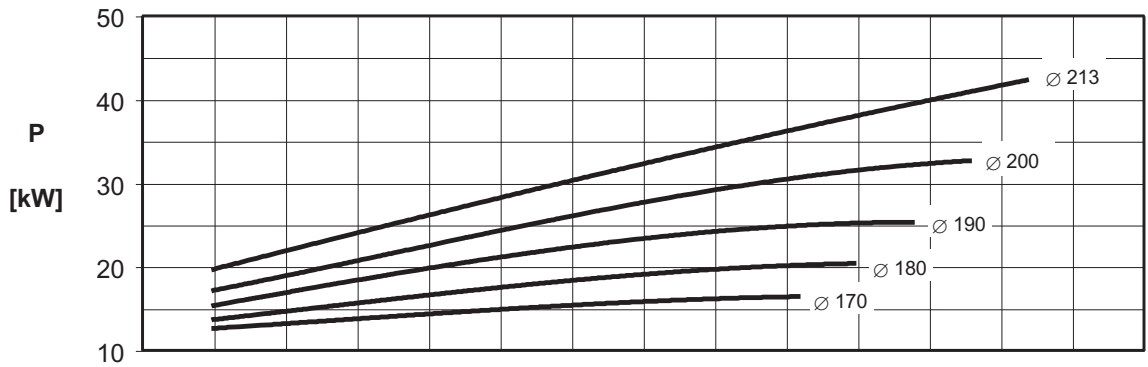
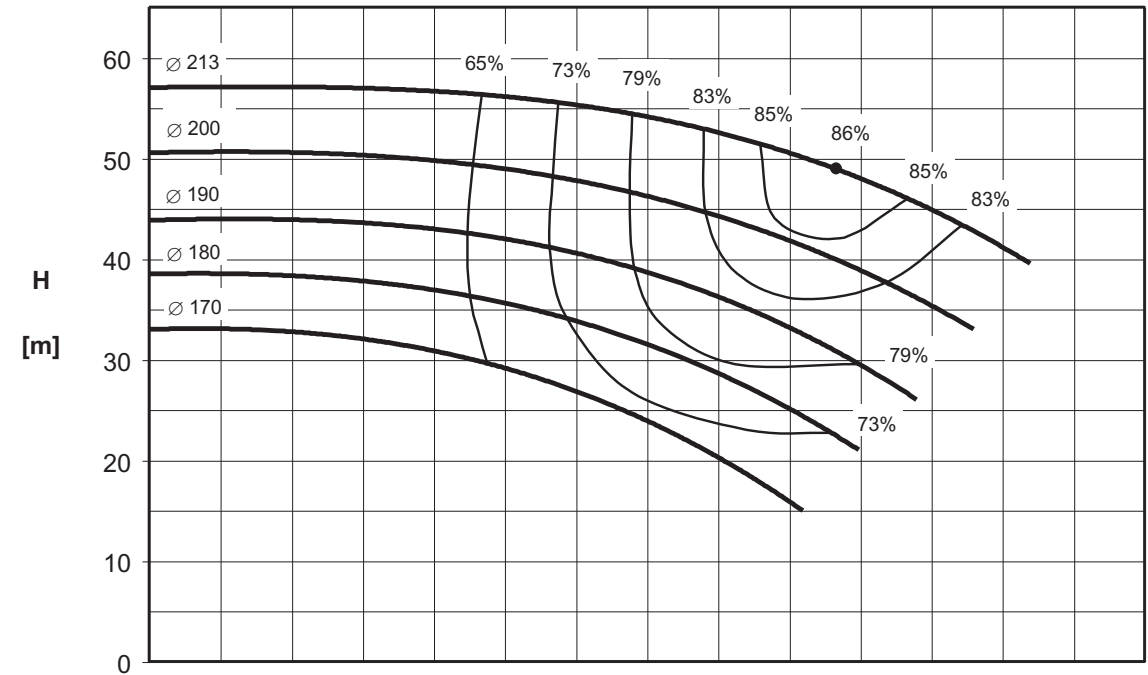

Rotation speed $\approx 2900 \text{ min}^{-1}$
 Test standard: ISO 9906 – Annex A

ENR 100-250 MEI > 0.40

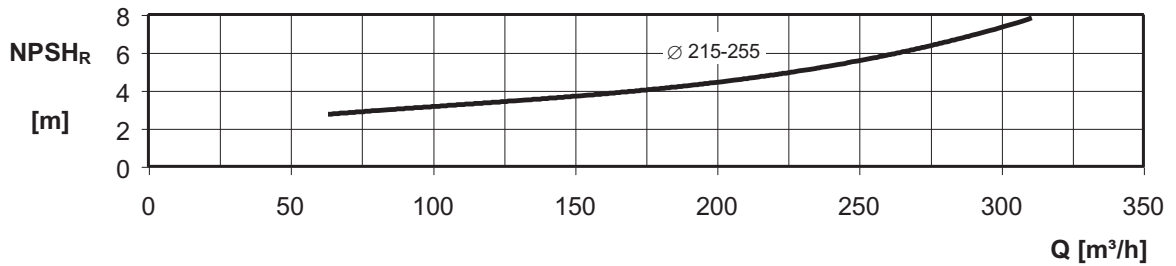
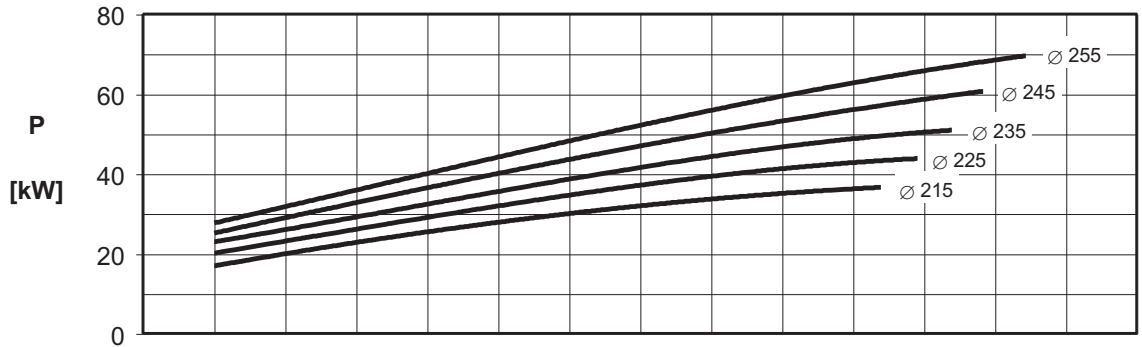
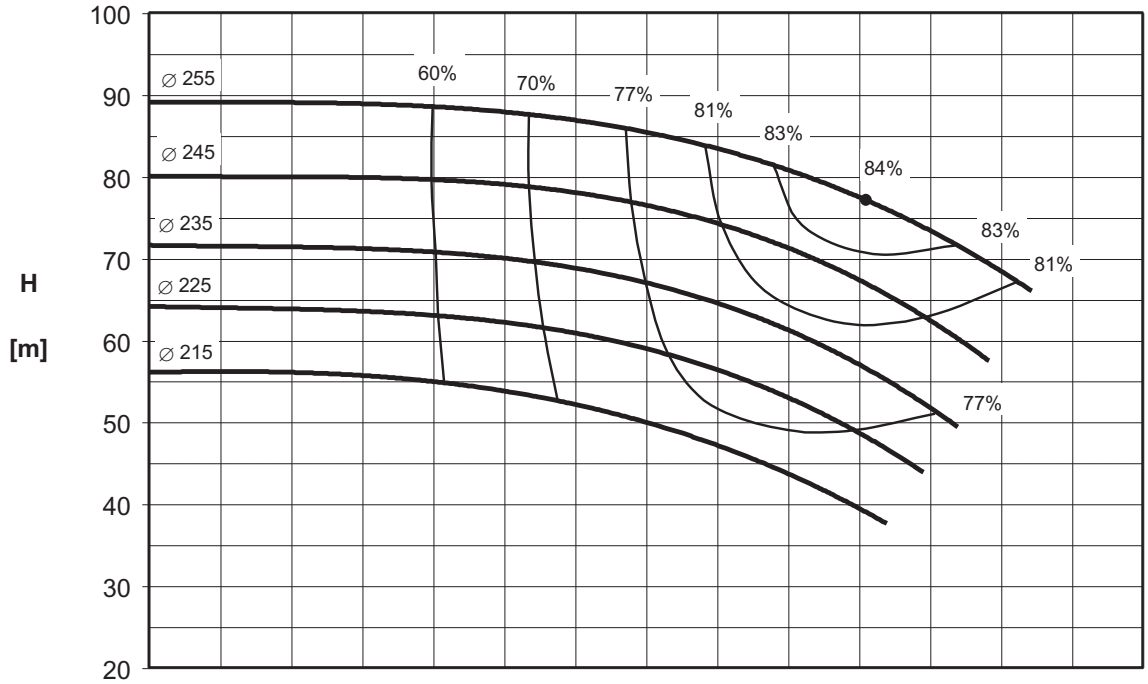

Rotation speed $\approx 2900 \text{ min}^{-1}$
 Test standard: ISO 9906 – Annex A

ENR 125-200 MEI > 0.40

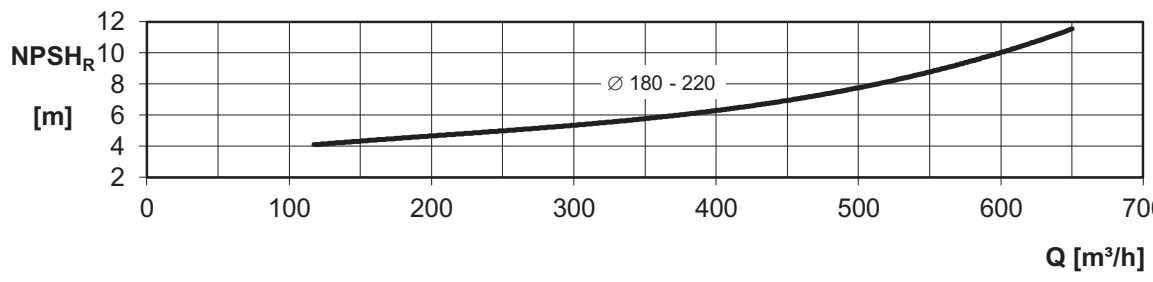
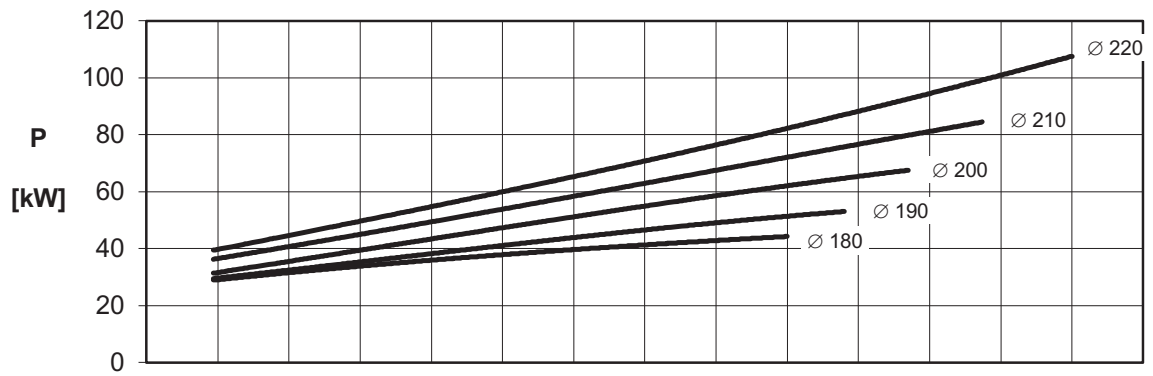
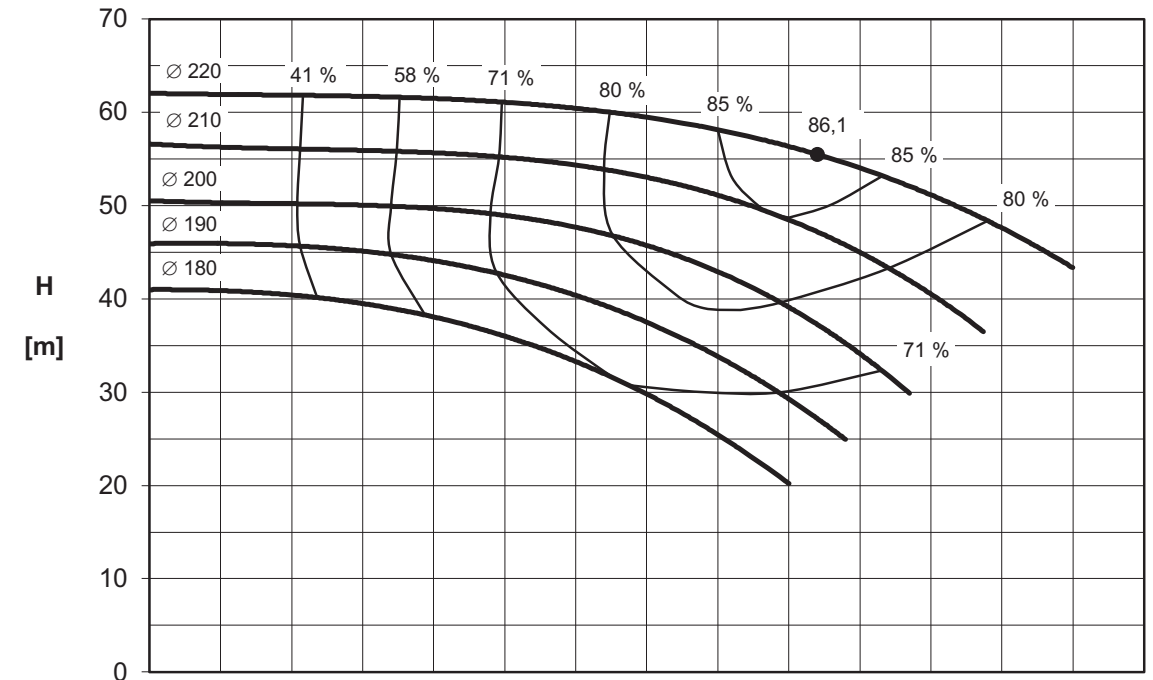

Rotation speed $\approx 2900 \text{ min}^{-1}$
 Test standard: ISO 9906 – Annex A

SECTIONAL VIEW

25 – 35 - 45

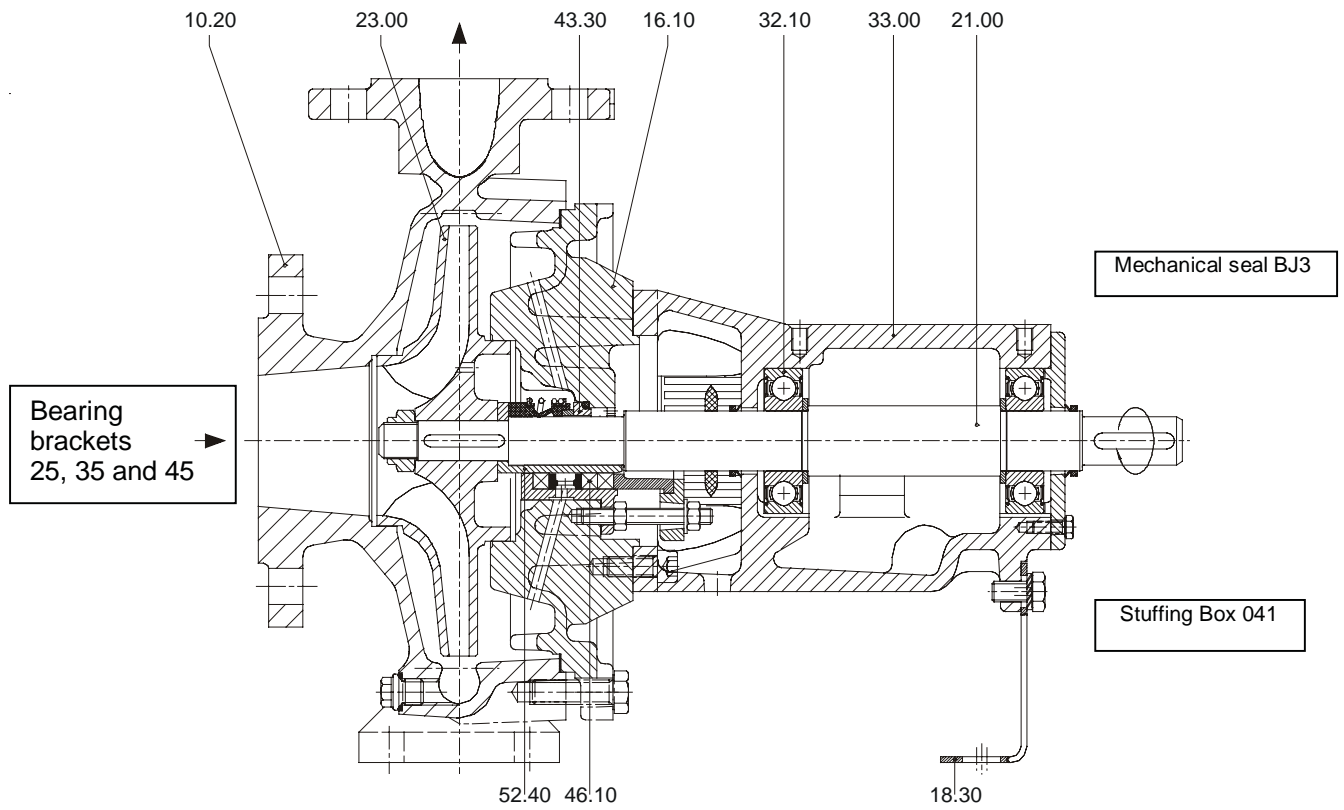

N°	PART NAME
10.20	volute casing
16.10	casing cover
18.30	support foot
21.00	shaft
23.00	impeller
32.10	ball bearing
33.00	bearing bracket
43.30	mechanical seal
46.10	stuffing box
52.40	shaft sleeve (stuffing box)

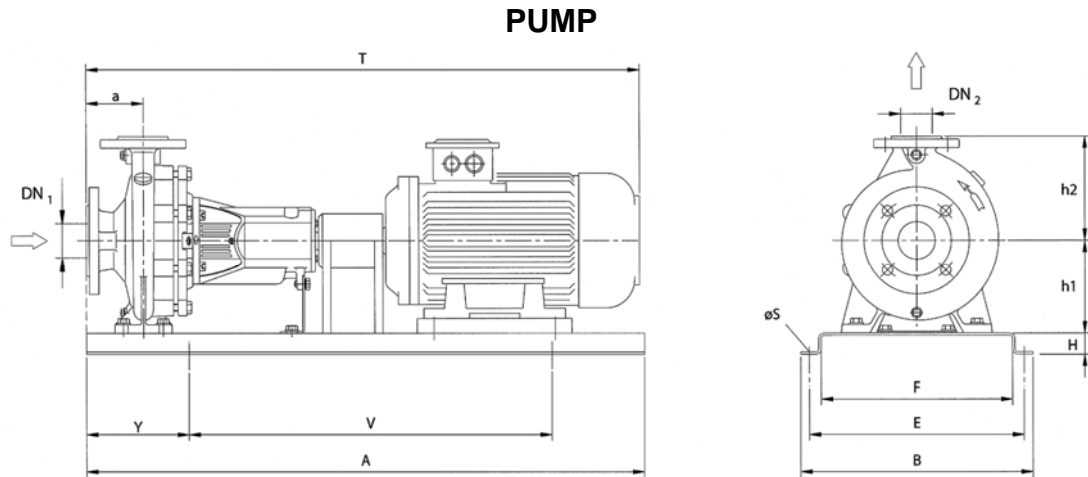

Dimension table 32 - 40

Model	Motor		Dimensions [mm]														[kgf]
	[Kw]	MEC	DN2	DN1	a	h2	h1	Standard Coupling							T		
								A	B	F	Y	V	E	H	S		
ENR 32-125	0,75	80	32	50	80	140	112	900	390	300	150	600	350	50	18	714	70,0
ENR 32-125	1,1	80	32	50	80	140	112	900	390	300	150	600	350	50	18	714	70,0
ENR 32-125	1,5	90S	32	50	80	140	112	900	390	300	150	600	350	50	18	764	73,0
ENR 32-125	2,2	90L	32	50	80	140	112	900	390	300	150	600	350	50	18	764	76,0
ENR 32-160	1,5	90S	32	50	80	160	132	900	390	300	150	600	350	50	18	764	74,0
ENR 32-160	2,2	90L	32	50	80	160	132	900	390	300	150	600	350	50	18	764	77,0
ENR 32-160	3	100L	32	50	80	160	132	900	390	300	150	600	350	50	18	844	87,0
ENR 32-160	4	112	32	50	80	160	132	900	490	380	150	600	440	50	18	844	99,0
ENR 32-160	5,5	132S	32	50	80	160	132	900	490	380	150	600	440	50	18	926	110,0
ENR 32-200	2,2	90L	32	50	80	180	160	900	390	300	150	600	350	50	18	764	84,0
ENR 32-200	3	100L	32	50	80	180	160	900	390	300	150	600	350	50	18	844	91,0
ENR 32-200	4	112	32	50	80	180	160	900	490	380	150	600	440	50	18	844	103,0
ENR 32-200	5,5	132S	32	50	80	180	160	900	490	380	150	600	440	50	18	926	121,0
ENR 32-200	7,5	132S	32	50	80	180	160	900	490	380	150	600	440	50	18	926	121,0
ENR 32-200	11	160M	32	50	80	180	160	1120	490	380	190	740	440	50	22	1092	167,0
ENR 32-250	7,5	132S	32	50	100	225	180	900	490	380	150	600	440	50	18	946	132,0
ENR 32-250	11	160M	32	50	100	225	180	1120	610	480	190	740	550	50	22	1112	187,0
ENR 32-250	15	160M	32	50	100	225	180	1120	610	480	190	740	550	50	22	1112	187,0
ENR 32-250	18,5	160L	32	50	100	225	180	1120	610	480	190	740	550	50	22	1112	201,0
ENR 40-125	1,1	80	40	65	80	140	112	900	390	300	150	600	350	50	18	714	71,0
ENR 40-125	1,5	90S	40	65	80	140	112	900	390	300	150	600	350	50	18	764	74,0
ENR 40-125	2,2	90L	40	65	80	140	112	900	390	300	150	600	350	50	18	764	77,0
ENR 40-125	3	100L	40	65	80	140	112	900	390	300	150	600	350	50	18	844	87,0
ENR 40-125	5,5	132S	40	65	80	140	132	900	490	380	150	600	440	50	18	926	114,0
ENR 40-160	1,5	90S	40	65	80	160	132	900	390	300	150	600	350	50	18	764	82,0
ENR 40-160	2,2	90L	40	65	80	160	132	900	390	300	150	600	350	50	18	764	83,0
ENR 40-160	3	100L	40	65	80	160	132	900	390	300	150	600	350	50	18	844	93,0
ENR 40-160	4	112	40	65	80	160	132	900	490	380	150	600	440	50	18	844	104,0
ENR 40-160	5,5	132S	40	65	80	160	132	900	490	380	150	600	440	50	18	926	115,0

Dimension table 40 - 50

Model	Motor		Dimensions [mm]														[kgf]
	[Kw]	MEC	DN2	DN1	a	h2	h1	Standard coupling									
								A	B	F	Y	V	E	H	S	T	
ENR 40-200	3	100L	40	65	100	180	160	900	490	380	150	600	440	50	18	864	97,0
ENR 40-200	4	112	40	65	100	180	160	900	490	380	150	600	440	50	18	864	106,0
ENR 40-200	5,5	132S	40	65	100	180	160	900	490	380	150	600	440	50	18	946	121,0
ENR 40-200	7,5	132S	40	65	100	180	160	900	490	380	150	600	440	50	18	946	121,0
ENR 40-200	11	160M	40	65	100	180	160	1120	490	380	190	740	440	50	22	1112	167,0
ENR 40-200	15	160M	40	65	100	180	160	1120	490	380	190	740	440	50	22	1112	167,0
ENR 40-250	7,5	132S	40	65	100	225	180	900	490	380	150	600	440	50	18	946	12,0
ENR 40-250	11	160M	40	65	100	225	180	1120	490	380	190	740	440	50	22	1112	178,0
ENR 40-250	15	160M	40	65	100	225	180	1120	490	380	190	740	440	50	22	1112	178,0
ENR 40-250	18,5	160L	40	65	100	225	180	1120	610	480	190	740	550	50	22	1112	201,0
ENR 40-250	22	180M	40	65	100	225	180	1120	610	480	190	740	550	50	22	1150	224,0
ENR 40-315	15	160M	40	65	125	250	225	1400	610	480	230	940	550	75	26	1247	242,0
ENR 40-315	18,5	160L	40	65	125	250	225	1400	610	480	230	940	550	75	26	1247	256,0
ENR 40-315	22	180M	40	65	125	250	225	1400	610	480	230	940	550	75	26	1285	280,0
ENR 40-315	30	200L	40	65	125	250	225	1400	610	480	230	940	550	75	26	1322	345,0
ENR 40-315	37	200L	40	65	125	250	225	1400	610	480	230	940	550	75	26	1322	345,0
ENR 50-125	1,5	90S	50	65	100	160	132	900	390	300	150	600	350	50	18	784	82,0
ENR 50-125	2,2	90L	50	65	100	160	132	900	390	300	150	600	350	50	18	784	83,0
ENR 50-125	3	100L	50	65	100	160	132	900	390	300	150	600	350	50	18	864	93,0
ENR 50-125	4	112	50	65	100	160	132	900	490	380	150	600	440	50	18	864	104,0
ENR 50-125	5,5	132S	50	65	100	160	132	900	490	380	150	600	440	50	18	946	115,0
ENR 50-125	7,5	132S	50	65	100	160	132	900	490	380	150	600	440	50	18	946	115,0
ENR 50-160	2,2	90L	50	65	100	180	160	900	490	380	150	600	440	50	18	784	87,0
ENR 50-160	3	100L	50	65	100	180	160	900	490	380	150	600	440	50	18	864	97,0
ENR 50-160	4	112	50	65	100	180	160	900	490	380	150	600	440	50	18	864	103,0
ENR 50-160	5,5	132S	50	65	100	180	160	900	490	380	150	600	440	50	18	946	119,0
ENR 50-160	7,5	132S	50	65	100	180	160	900	490	380	150	600	440	50	18	946	119,0
ENR 50-160	11	160M	50	65	100	180	160	1120	490	380	190	740	440	50	22	1112	165,0
ENR 50-160	15	160M	50	65	100	180	180	1120	490	380	190	740	440	50	22	1112	165,0
ENR 50-200	3	100L	50	65	100	200	160	900	490	380	150	600	440	50	18	864	102,0
ENR 50-200	4	112	50	65	100	200	160	900	490	380	150	600	440	50	18	864	109,0
ENR 50-200	5,5	132S	50	65	100	200	160	900	490	380	150	600	440	50	18	946	123,0
ENR 50-200	7,5	132S	50	65	100	200	160	900	490	380	150	600	440	50	18	946	123,0
ENR 50-200	11	160M	50	65	100	200	160	1120	490	380	190	740	440	50	22	1112	169,0
ENR 50-200	15	160M	50	65	100	200	160	1120	490	380	190	740	440	50	22	1112	169,0
ENR 50-200	18,5	160L	50	65	100	200	160	1120	490	380	190	740	440	50	22	1112	183,0
ENR 50-200	22	180M	50	65	100	200	180	1120	610	480	190	740	550	50	22	1150	217,0
ENR 50-250	15	160M	50	65	100	225	180	1120	610	480	190	740	550	50	22	1112	194,0
ENR 50-250	18,5	160L	50	65	100	225	180	1120	610	480	190	740	550	50	22	1112	207,0
ENR 50-250	22	180M	50	65	100	225	180	1120	610	480	190	740	550	50	22	1150	232,0
ENR 50-250	30	200L	50	65	100	225	200	1120	610	480	190	740	550	50	22	1187	296,0
ENR 50-315	22	180M	50	65	125	280	225	1400	610	480	230	940	550	75	26	1285	280,0
ENR 50-315	30	200L	50	65	125	280	225	1400	610	480	230	940	550	75	26	1322	345,0
ENR 50-315	37	200L	50	65	125	280	225	1400	610	480	230	940	550	75	26	1322	345,0
ENR 50-315	45	225M	50	65	125	280	225	1400	730	600	230	940	670	75	26	1429	404,0
ENR 50-315	55	250M	50	65	125	280	250	1600	660	530	270	1060	600	75	26	1429	438,0
ENR 50-315	75	280S	50	65	125	280	280	1800	730	600	300	1200	670	100	26	1559	572,0

Dimension table 65 - 80 – 100

Model	Motor		Dimensions [mm]														[kgf]
	[Kw]	MEC	DN2	DN1	a	h2	h1	Standard coupling									
								A	B	F	Y	V	E	H	S	T	
ENR 65-125	3	100L	65	80	100	180	160	900	490	380	150	600	440	50	18	864	95,0
ENR 65-125	4	112	65	80	100	180	160	900	490	380	150	600	440	50	18	864	102,0
ENR 65-125	5,5	132S	65	80	100	180	160	900	490	380	150	600	440	50	18	946	117,0
ENR 65-125	7,5	132S	65	80	100	180	160	900	490	380	150	600	440	50	18	946	117,0
ENR 65-125	11	160M	65	80	100	180	160	1120	490	380	190	740	440	50	22	1112	163,0
ENR 65-160	5,5	132S	65	80	100	200	160	900	490	380	150	600	440	50	18	946	122,0
ENR 65-160	7,5	132S	65	80	100	200	160	900	490	380	150	600	440	50	18	946	122,0
ENR 65-160	11	160M	65	80	100	200	160	1120	490	380	190	740	440	50	22	1112	168,0
ENR 65-160	15	160M	65	80	100	200	160	1120	490	380	190	740	440	50	22	1112	168,0
ENR 65-160	18,5	160L	65	80	100	200	160	1120	490	380	190	740	440	50	22	1112	182,0
ENR 65-200	11	160M	65	80	100	225	180	1120	610	480	190	740	550	50	22	1112	186,0
ENR 65-200	15	160M	65	80	100	225	180	1120	610	480	190	740	550	50	22	1112	186,0
ENR 65-200	18,5	160L	65	80	100	225	180	1120	610	480	190	740	550	50	22	1112	200,0
ENR 65-200	22	180M	65	80	100	225	180	1120	610	480	190	740	550	50	22	1150	225,0
ENR 65-200	30	200L	65	80	100	225	200	1120	610	480	190	740	550	50	22	1187	288,0
ENR 65-250	18,5	160L	65	80	100	250	200	1400	610	480	230	940	550	75	26	1222	249,0
ENR 65-250	22	180M	65	80	100	250	200	1400	610	480	230	940	550	75	26	1260	273,0
ENR 65-250	30	200L	65	80	100	250	200	1400	610	480	230	940	550	75	26	1297	337,0
ENR 65-250	37	200L	65	80	100	250	200	1400	610	480	230	940	550	75	26	1297	337,0
ENR 65-250	45	225M	65	80	100	250	225	1400	730	600	230	940	670	75	26	1404	396,0
ENR 80-160	7,5	132S	80	100	125	225	180	1120	490	380	190	740	440	50	22	971	143,0
ENR 80-160	11	160M	80	100	125	225	180	1120	610	480	190	740	550	50	22	1137	182,0
ENR 80-160	15	160M	80	100	125	225	180	1120	610	480	190	740	550	50	22	1137	182,0
ENR 80-160	18,5	160L	80	100	125	225	180	1120	610	480	190	740	550	50	22	1137	196,0
ENR 80-160	22	180M	80	100	125	225	180	1120	610	480	190	740	550	50	22	1175	220,0
ENR 80-160	30	200L	80	100	125	225	200	1120	610	480	190	740	550	50	22	1212	284,0
ENR 80-200	15	160M	80	100	125	250	180	1400	610	480	230	940	550	75	26	1247	224,0
ENR 80-200	18,5	160L	80	100	125	250	180	1400	610	480	230	940	550	75	26	1247	238,0
ENR 80-200	22	180M	80	100	125	250	180	1400	610	480	230	940	550	75	26	1285	262,0
ENR 80-200	30	200L	80	100	125	250	200	1400	610	480	230	940	550	75	26	1322	327,0
ENR 80-200	37	200L	80	100	125	250	200	1400	610	480	230	940	550	75	26	1322	327,0
ENR 80-200	45	225M	80	100	125	250	225	1400	730	600	230	940	670	75	26	1429	385,0
ENR 80-250	22	180M	80	100	125	280	200	1400	610	480	230	940	550	75	26	1285	275,0
ENR 80-250	30	200L	80	100	125	280	200	1400	610	480	230	940	550	75	26	1322	338,0
ENR 80-250	37	200L	80	100	125	280	200	1400	610	480	230	940	550	75	26	1322	338,0
ENR 80-250	45	225M	80	100	125	280	225	1400	730	600	230	940	670	75	26	1429	397,0
ENR 80-250	55	250M	80	100	125	280	250	1600	660	530	270	1060	600	75	26	1429	431,0
ENR 80-250	75	280S	80	100	125	280	280	1800	730	600	300	1200	670	100	26	1559	565,0
ENR 100-160	18,5	160L	100	125	125	280	200	1400	610	480	230	940	550	75	26	1247	242,0
ENR 100-160	22	180M	100	125	125	280	200	1400	610	480	230	940	550	75	26	1285	266,0
ENR 100-160	30	200L	100	125	125	280	200	1400	610	480	230	940	550	75	26	1322	330,0
ENR 100-160	37	200L	100	125	125	280	200	1400	610	480	230	940	550	75	26	1322	330,0
ENR 100-200	18,5	160L	100	125	125	280	200	1400	610	480	230	940	550	75	26	1247	245,0
ENR 100-200	22	180M	100	125	125	280	200	1400	610	480	230	940	550	75	26	1285	269,0
ENR 100-200	30	200L	100	125	125	280	200	1400	610	480	230	940	550	75	26	1322	333,0
ENR 100-200	37	200L	100	125	125	280	200	1400	610	480	230	940	550	75	26	1322	333,0
ENR 100-200	45	225M	100	125	125	280	225	1400	730	600	230	940	670	75	26	1429	392,0
ENR 100-200	75	280S	100	125	125	280	280	1800	730	600	300	1200	670	100	26	1559	560,0

Dimension table 100 – 125

MODEL	MOTOR		DIMENSIONS [mm]															
	[Kw]	MEC	DN2	DN1	a	h2	h1	STANDARD COUPLING										[kgf]
								A	B	F	Y	V	E	H	S	T		
ENR 100-250	30	200L	100	125	140	280	225	1400	730	600	230	940	670	75	26	1337	368,0	
ENR 100-250	37	200L	100	125	140	280	225	1400	730	600	230	940	670	75	26	1337	368,0	
ENR 100-250	45	225M	100	125	140	280	225	1600	660	530	270	1060	600	75	26	1444	417,0	
ENR 100-250	55	250M	100	125	140	280	250	1600	660	530	270	1060	600	75	26	1444	447,0	
ENR 100-250	75	280S	100	125	140	280	280	1800	730	600	300	1200	670	100	26	1574	581,0	
ENR 100-250	90	280M	100	125	140	280	280	1800	730	600	300	1200	670	100	26	1574	627,0	
ENR 125-200	37	200L	125	150	140	315	250	1400	730	600	230	940	670	75	26	1337	383,0	
ENR 125-200	45	225M	125	150	140	315	250	1600	660	530	270	1060	600	75	26	1444	432,0	
ENR 125-200	55	250M	125	150	140	315	250	1600	660	530	270	1060	600	75	26	1444	462,0	
ENR 125-200	75	280S	125	150	140	315	280	1800	730	600	300	1200	670	100	26	1574	595,0	
ENR 125-200	90	280M	125	150	140	315	280	1800	730	600	300	1200	670	100	26	1574	641,0	
ENR 125-200	110	315S	125	150	140	315	315	1800	850	700	300	1200	780	100	26	1574	670,0	

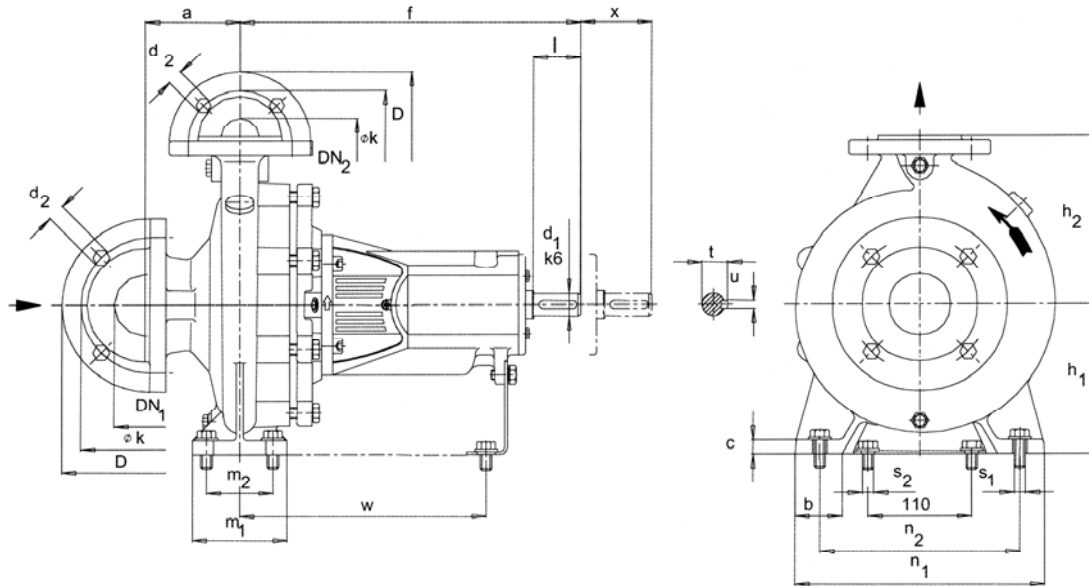

Model	Supp	Dimensions [mm]																				Weight [kgf]
		Pump							Support							Shaft protuberance						
		DN2	DN1	a	f	h2	h1	b	c	m1	m2	n1	n2	s1	s2	w	x	d1	l	t	u	
ENR 32-125	25	32	50	80	360	112	140	50	15	100	70	190	140	M12	M12	260	100	24	50	27	8	31,0
ENR 32-160	25	32	50	80	360	132	160	50	15	100	70	240	190	M12	M12	260	100	24	50	27	8	33,0
ENR 32-200	25	32	50	80	360	160	180	50	15	100	70	240	190	M12	M12	260	100	24	50	27	8	34,0
ENR 32-250	25	32	50	100	360	180	225	65	15	125	95	320	250	M12	M12	260	100	24	50	27	8	46,0
ENR 40-125	25	40	65	80	360	112	140	50	15	100	70	210	160	M12	M12	260	100	24	50	27	8	28,0
ENR 40-160	25	40	65	80	360	132	160	50	15	100	70	240	190	M12	M12	260	100	24	50	27	8	30,0
ENR 40-200	25	40	65	100	360	160	180	50	15	100	70	265	212	M12	M12	260	100	24	50	27	8	36,0
ENR 40-250	25	40	65	100	360	180	225	65	15	125	95	320	250	M12	M12	260	100	24	50	27	8	46,0
ENR 40-315	35	40	65	125	470	225	250	65	18	125	95	345	280	M12	M12	340	100	32	80	35	10	73,0
ENR 50-125	25	50	65	100	360	132	160	50	15	100	70	240	190	M12	M12	260	100	24	50	27	8	30,0
ENR 50-160	25	50	65	100	360	160	180	50	15	100	70	265	212	M12	M12	260	100	24	50	27	8	36,0
ENR 50-200	25	50	65	100	360	160	200	50	15	100	70	265	212	M12	M12	260	100	24	50	27	8	40,0
ENR 50-250	25	50	65	100	360	180	225	65	15	125	95	320	250	M12	M12	260	100	24	50	27	8	50,0
ENR 50-315	35	50	65	125	470	225	280	65	17	125	95	345	280	M12	M12	340	100	32	80	35	10	88,0
ENR 65-125	25	65	80	100	360	160	180	65	15	125	95	280	212	M12	M12	260	100	24	50	27	8	33,0
ENR 65-160	25	65	80	100	360	160	200	65	15	125	95	280	212	M12	M12	260	100	24	50	27	8	39,0
ENR 65-200	25	65	80	100	360	180	225	65	15	125	95	320	250	M12	M12	260	140	24	50	27	8	45,0
ENR 65-250	35	65	80	100	470	200	250	80	15	160	120	360	280	M16	M12	340	140	32	80	35	10	70,0
ENR 80-160	25	80	100	125	360	180	225	65	15	125	95	320	250	M12	M12	260	140	24	50	27	8	43,0
ENR 80-200	35	80	100	125	470	180	250	65	15	125	95	345	280	M12	M12	340	140	32	80	35	10	60,0
ENR 80-250	35	80	100	125	470	200	280	80	18	160	120	400	315	M16	M12	340	140	32	80	35	10	75,0
ENR 100-160	35	100	125	125	470	200	280	80	18	160	120	360	280	M16	M12	340	140	32	80	35	10	78,0
ENR 100-200	35	100	125	125	470	200	280	80	18	160	120	360	280	M16	M12	340	140	32	80	35	10	70,0
ENR 100-250	35	100	125	140	470	225	280	80	18	160	120	400	315	M16	M12	340	140	32	80	35	10	85,0
ENR 125-200	35	125	150	140	470	250	315	80	18	160	120	400	315	M16	M12	340	140	32	80	35	10	100,0

MOTOR DATA ENR 32 - 40 - 50

Pump type Three Phase	Power		Efficiency Three Phase	Efficiency (%) Three phase η %			Input [kW]	Full load current [A]			Locked rotor current [A]		
	[kW]	[HP]		50%	75%	100%		230 V	400 V	690 V	230 V	400 V	690 V
	ENR 32-125/0,75	0,75		1	IE2	77,3		78,5	80,5	0,92	2,9	1,7	-
ENR 32-125/1,1	1,1	1,5	IE2	79,5	81,2	81,5	1,35	4,3	2,5	-	41,1	23,8	-
ENR 32-125/1,5	1,5	2	IE2	81,0	82,8	82,8	1,77	5,5	3,2	-	56,0	32,3	-
ENR 32-125/2,2	2,2	3	IE2	82,5	84,0	84,0	2,59	7,6	4,4	-	77,0	44,4	-
ENR 32-160/1,5	1,5	2	IE2	81,0	82,8	82,8	1,77	5,5	3,2	-	56,0	32,3	-
ENR 32-160/2,2	2,2	3	IE2	82,5	84,0	84,0	2,59	7,6	4,4	-	77,0	44,4	-
ENR 32-160/3	3	4	IE2	84,1	85,8	85,5	3,43	10,2	5,9	-	105,3	60,8	-
ENR 32-160/4	4	5,5	IE2	85,5	87,0	86,8	4,63	13,2	7,6	-	140,9	81,3	-
ENR 32-160/5,5	5,5	7,5	IE2	86,0	88,0	87,9	6,29	-	10,2	5,9	-	87,7	50,6
ENR 32-200/2,2	2,2	3	IE2	82,5	84,0	84,0	2,59	7,6	4,4	-	77,0	44,4	-
ENR 32-200/3	3	4	IE2	84,1	85,8	85,5	3,43	10,2	5,9	-	105,3	60,8	-
ENR 32-200/4	4	5,5	IE2	85,5	87,0	86,8	4,63	13,2	7,6	-	140,9	81,3	-
ENR 32-200/5,5	5,5	7,5	IE2	86,0	88,0	87,9	6,29	-	10,2	5,9	-	87,7	50,6
ENR 32-200/7,5	7,5	10	IE2	86,3	88,6	88,4	8,51	-	13,8	8,0	-	122,8	70,9
ENR 32-200/11	11	15	IE2	88,9	90,2	90,0	12,30	-	20,4	11,8	-	189,7	109,5
ENR 32-250/7,5	7,5	10	IE2	86,3	88,6	88,4	8,51	-	13,8	8,0	-	122,8	70,9
ENR 32-250/11	11	15	IE2	88,9	90,2	90,0	12,30	-	20,4	11,8	-	189,7	109,5
ENR 32-250/15	15	20	IE2	90,0	91,0	90,8	16,58	-	27,2	15,7	-	261,1	150,8
ENR 32-250/18,5	18,5	25	IE2	90,3	91,6	91,2	20,30	-	33,3	19,2	-	319,7	184,6
ENR 40-125/1,1	1,1	1,5	IE2	79,5	81,2	81,5	1,35	4,3	2,5	-	41,1	23,8	-
ENR 40-125/1,5	1,5	2	IE2	81,0	82,8	82,8	1,77	5,5	3,2	-	56,0	32,3	-
ENR 40-125/2,2	2,2	3	IE2	82,5	84,0	84,0	2,59	7,6	4,4	-	77,0	44,4	-
ENR 40-125/3	3	4	IE2	84,1	85,8	85,5	3,43	10,2	5,9	-	105,3	60,8	-
ENR 40-125/5,5	5,5	7,5	IE2	86,0	88,0	87,9	6,29	-	10,2	5,9	-	87,7	50,6
ENR 40-160/1,5	1,5	2	IE2	81,0	82,8	82,8	1,77	5,5	3,2	-	56,0	32,3	-
ENR 40-160/2,2	2,2	3	IE2	82,5	84,0	84,0	2,59	7,6	4,4	-	77,0	44,4	-
ENR 40-160/3	3	4	IE2	84,1	85,8	85,5	3,43	10,2	5,9	-	105,3	60,8	-
ENR 40-160/4	4	5,5	IE2	85,5	87,0	86,8	4,63	13,2	7,6	-	140,9	81,3	-
ENR 40-160/5,5	5,5	7,5	IE2	86,0	88,0	87,9	6,29	-	10,2	5,9	-	87,7	50,6
ENR 40-200/3	3	4	IE2	84,1	85,8	85,5	3,43	10,2	5,9	-	105,3	60,8	-
ENR 40-200/4	4	5,5	IE2	85,5	87,0	86,8	4,63	13,2	7,6	-	140,9	81,3	-
ENR 40-200/5,5	5,5	7,5	IE2	86,0	88,0	87,9	6,29	-	10,2	5,9	-	87,7	50,6
ENR 40-200/7,5	7,5	10	IE2	86,3	88,6	88,4	8,51	-	13,8	8,0	-	122,8	70,9
ENR 40-200/11	11	15	IE2	88,9	90,2	90,0	12,30	-	20,4	11,8	-	189,7	109,5
ENR 40-200/15	15	20	IE2	90,0	91,0	90,8	16,58	-	27,2	15,7	-	261,1	150,8
ENR 40-250/7,5	7,5	10	IE2	86,3	88,6	88,4	8,51	-	13,8	8,0	-	122,8	70,9
ENR 40-250/11	11	15	IE2	88,9	90,2	90,0	12,30	-	20,4	11,8	-	189,7	109,5
ENR 40-250/15	15	20	IE2	90,0	91,0	90,8	16,58	-	27,2	15,7	-	261,1	150,8
ENR 40-250/18,5	18,5	25	IE2	90,3	91,6	91,2	20,30	-	33,3	19,2	-	319,7	184,6
ENR 40-250/22	22	30	IE2	90,9	91,8	91,4	24,07	-	39,0	22,5	-	292,8	169,0
ENR 40-315/15	15	20	IE2	90,0	91,0	90,8	16,58	-	27,2	15,7	-	261,1	150,8
ENR 40-315/18,5	18,5	25	IE2	90,3	91,6	91,2	20,30	-	33,3	19,2	-	319,7	184,6
ENR 40-315/22	22	30	IE2	90,9	91,8	91,4	24,07	-	39,0	22,5	-	292,8	169,0
ENR 40-315/30	30	40	IE2	91,3	92,3	92,4	32,50	-	53,3	30,8	-	357,1	206,2
ENR 40-315/37	37	50	IE2	91,6	92,9	92,8	39,91	-	64,0	37,0	-	403,2	232,8
ENR 50-125/1,5	1,5	2	IE2	81,0	82,8	82,8	1,77	5,5	3,2	-	56,0	32,3	-
ENR 50-125/2,2	2,2	3	IE2	82,5	84,0	84,0	2,59	7,6	4,4	-	77,0	44,4	-
ENR 50-125/3	3	4	IE2	84,1	85,8	85,5	3,43	10,2	5,9	-	105,3	60,8	-
ENR 50-125/4	4	5,5	IE2	85,5	87,0	86,8	4,63	13,2	7,6	-	140,9	81,3	-
ENR 50-125/5,5	5,5	7,5	IE2	86,0	88,0	87,9	6,29	-	10,2	5,9	-	87,7	50,6
ENR 50-125/7,5	7,5	10	IE2	86,3	88,6	88,4	8,51	-	13,8	8,0	-	122,8	70,9

MOTOR DATA ENR 50 - 65

Pump type Three Phase	Power		Efficiency Three Phase	Efficiency (%) Three phase η %			Input [kW]	Full load current [A]			Locked rotor current [A]		
	[kW]	[HP]		50%	75%	100%		230 V	400 V	690 V	230 V	400 V	690 V
ENR 50-160/2,2	2,2	3	IE2	82,5	84,0	84,0	2,59	7,6	4,4	-	77,0	44,4	-
ENR 50-160/3	3	4	IE2	84,1	85,8	85,5	3,43	10,2	5,9	-	105,3	60,8	-
ENR 50-160/4	4	5,5	IE2	85,5	87,0	86,8	4,63	13,2	7,6	-	140,9	81,3	-
ENR 50-160/5,5	5,5	7,5	IE2	86,0	88,0	87,9	6,29	-	10,2	5,9	-	87,7	50,6
ENR 50-160/7,5	7,5	10	IE2	86,3	88,6	88,4	8,51	-	13,8	8,0	-	122,8	70,9
ENR 50-160/11	11	15	IE2	88,9	90,2	90,0	12,30	-	20,4	11,8	-	189,7	109,5
ENR 50-160/15	15	20	IE2	90,0	91,0	90,8	16,58	-	27,2	15,7	-	261,1	150,8
ENR 50-200/3	3	4	IE2	84,1	85,8	85,5	3,43	10,2	5,9	-	105,3	60,8	-
ENR 50-200/4	4	5,5	IE2	85,5	87,0	86,8	4,63	13,2	7,6	-	140,9	81,3	-
ENR 50-200/5,5	5,5	7,5	IE2	86,0	88,0	87,9	6,29	-	10,2	5,9	-	87,7	50,6
ENR 50-200/7,5	7,5	10	IE2	86,3	88,6	88,4	8,51	-	13,8	8,0	-	122,8	70,9
ENR 50-200/11	11	15	IE2	88,9	90,2	90,0	12,30	-	20,4	11,8	-	189,7	109,5
ENR 50-200/15	15	20	IE2	90,0	91,0	90,8	16,58	-	27,2	15,7	-	261,1	150,8
ENR 50-200/18,5	18,5	25	IE2	90,3	91,6	91,2	20,30	-	33,3	19,2	-	319,7	184,6
ENR 50-200/22	22	30	IE2	90,9	91,8	91,4	24,07	-	39,0	22,5	-	292,8	169,0
ENR 50-250/15	15	20	IE2	90,0	91,0	90,8	16,58	-	27,2	15,7	-	261,1	150,8
ENR 50-250/18,5	18,5	25	IE2	90,3	91,6	91,2	20,30	-	33,3	19,2	-	319,7	184,6
ENR 50-250/22	22	30	IE2	90,9	91,8	91,4	24,07	-	39,0	22,5	-	292,8	169,0
ENR 50-250/30	30	40	IE2	91,3	92,3	92,4	32,50	-	53,3	30,8	-	357,1	206,2
ENR 50-315/22	22	30	IE2	90,9	91,8	91,4	24,07	-	39,0	22,5	-	292,8	169,0
ENR 50-315/30	30	40	IE2	91,3	92,3	92,4	32,50	-	53,3	30,8	-	357,1	206,2
ENR 50-315/37	37	50	IE2	91,6	92,9	92,8	39,91	-	64,0	37,0	-	403,2	232,8
ENR 50-315/45	45	60	IE2	92,8	93,3	93,2	48,28	-	78,3	45,2	-	540,3	311,9
ENR 50-315/55	55	75	IE2	92,9	93,8	93,7	58,67	-	94,1	54,3	-	752,8	434,6
ENR 50-315/75	75	100	IE2	93,2	94,5	94,1	79,69	-	127,8	73,8	-	1022,4	590,3
ENR 65-125/3	3	4	IE2	84,1	85,8	85,5	3,43	10,2	5,9	-	105,3	60,8	-
ENR 65-125/4	4	5,5	IE2	85,5	87,0	86,8	4,63	13,2	7,6	-	140,9	81,3	-
ENR 65-125/5,5	5,5	7,5	IE2	86,0	88,0	87,9	6,29	-	10,2	5,9	-	87,7	50,6
ENR 65-125/7,5	7,5	10	IE2	86,3	88,6	88,4	8,51	-	13,8	8,0	-	122,8	70,9
ENR 65-125/11	11	15	IE2	88,9	90,2	90,0	12,30	-	20,4	11,8	-	189,7	109,5
ENR 65-160/5,5	5,5	7,5	IE2	86,0	88,0	87,9	6,29	-	10,2	5,9	-	87,7	50,6
ENR 65-160/7,5	7,5	10	IE2	86,3	88,6	88,4	8,51	-	13,8	8,0	-	122,8	70,9
ENR 65-160/11	11	15	IE2	88,9	90,2	90,0	12,30	-	20,4	11,8	-	189,7	109,5
ENR 65-160/15	15	20	IE2	90,0	91,0	90,8	16,58	-	27,2	15,7	-	261,1	150,8
ENR 65-160/18,5	18,5	25	IE2	90,3	91,6	91,2	20,30	-	33,3	19,2	-	319,7	184,6
ENR 65-200/11	11	15	IE2	88,9	90,2	90,0	12,30	-	20,4	11,8	-	189,7	109,5
ENR 65-200/15	15	20	IE2	90,0	91,0	90,8	16,58	-	27,2	15,7	-	261,1	150,8
ENR 65-200/18,5	18,5	25	IE2	90,3	91,6	91,2	20,30	-	33,3	19,2	-	319,7	184,6
ENR 65-200/22	22	30	IE2	90,9	91,8	91,4	24,07	-	39,0	22,5	-	292,8	169,0
ENR 65-200/30	30	40	IE2	91,3	92,3	92,4	32,50	-	53,3	30,8	-	357,1	206,2
ENR 65-250/18,5	18,5	25	IE2	90,3	91,6	91,2	20,30	-	33,3	19,2	-	319,7	184,6
ENR 65-250/22	22	30	IE2	90,9	91,8	91,4	24,07	-	39,0	22,5	-	292,8	169,0
ENR 65-250/30	30	40	IE2	91,3	92,3	92,4	32,50	-	53,3	30,8	-	357,1	206,2
ENR 65-250/37	37	50	IE2	91,6	92,9	92,8	39,91	-	64,0	37,0	-	403,2	232,8
ENR 65-250/45	45	60	IE2	92,8	93,3	93,2	48,28	-	78,3	45,2	-	540,3	311,9

MOTOR DATA ENR 80 - 100 - 125

Pump type Three Phase	Power		Efficiency Three Phase	Efficiency (%) Three phase η %			Input [kW]	Full load current [A]			Locked rotor current [A]		
	[kW]	[HP]		50%	75%	100%		230 V	400 V	690 V	230 V	400 V	690 V
ENR 80-160/7,5	7,5	10	IE2	86,3	88,6	88,4	8,51	-	13,8	8,0	-	122,8	70,9
ENR 80-160/11	11	15	IE2	88,9	90,2	90,0	12,30	-	20,4	11,8	-	189,7	109,5
ENR 80-160/15	15	20	IE2	90,0	91,0	90,8	16,58	-	27,2	15,7	-	261,1	150,8
ENR 80-160/18,5	18,5	25	IE2	90,3	91,6	91,2	20,30	-	33,3	19,2	-	319,7	184,6
ENR 80-160/22	22	30	IE2	90,9	91,8	91,4	24,07	-	39,0	22,5	-	292,8	169,0
ENR 80-160/30	30	40	IE2	91,3	92,3	92,4	32,50	-	53,3	30,8	-	357,1	206,2
ENR 80-200/15	15	20	IE2	90,0	91,0	90,8	16,58	-	27,2	15,7	-	261,1	150,8
ENR 80-200/18,5	18,5	25	IE2	90,3	91,6	91,2	20,30	-	33,3	19,2	-	319,7	184,6
ENR 80-200/22	22	30	IE2	90,9	91,8	91,4	24,07	-	39,0	22,5	-	292,8	169,0
ENR 80-200/30	30	40	IE2	91,3	92,3	92,4	32,50	-	53,3	30,8	-	357,1	206,2
ENR 80-200/37	37	50	IE2	91,6	92,9	92,8	39,91	-	64,0	37,0	-	403,2	232,8
ENR 80-200/45	45	60	IE2	92,8	93,3	93,2	48,28	-	78,3	45,2	-	540,3	311,9
ENR 80-250/22	22	30	IE2	90,9	91,8	91,4	24,07	-	39,0	22,5	-	292,8	169,0
ENR 80-250/30	30	40	IE2	91,3	92,3	92,4	32,50	-	53,3	30,8	-	357,1	206,2
ENR 80-250/37	37	50	IE2	91,6	92,9	92,8	39,91	-	64,0	37,0	-	403,2	232,8
ENR 80-250/45	45	60	IE2	92,8	93,3	93,2	48,28	-	78,3	45,2	-	540,3	311,9
ENR 80-250/55	55	75	IE2	92,9	93,8	93,7	58,67	-	94,1	54,3	-	752,8	434,6
ENR 80-250/75	75	100	IE2	93,2	94,5	94,1	79,69	-	127,8	73,8	-	1022,4	590,3
ENR 100-160/18,5	18,5	25	IE2	90,3	91,6	91,2	20,30	-	33,3	19,2	-	319,7	184,6
ENR 100-160/22	22	30	IE2	90,9	91,8	91,4	24,07	-	39,0	22,5	-	292,8	169,0
ENR 100-160/30	30	40	IE2	91,3	92,3	92,4	32,50	-	53,3	30,8	-	357,1	206,2
ENR 100-160/37	37	50	IE2	91,6	92,9	92,8	39,91	-	64,0	37,0	-	403,2	232,8
ENR 100-200/18,5	18,5	25	IE2	90,3	91,6	91,2	20,30	-	33,3	19,2	-	319,7	184,6
ENR 100-200/22	22	30	IE2	90,9	91,8	91,4	24,07	-	39,0	22,5	-	292,8	169,0
ENR 100-200/30	30	40	IE2	91,3	92,3	92,4	32,50	-	53,3	30,8	-	357,1	206,2
ENR 100-200/37	37	50	IE2	91,6	92,9	92,8	39,91	-	64,0	37,0	-	403,2	232,8
ENR 100-200/45	45	60	IE2	92,8	93,3	93,2	48,28	-	78,3	45,2	-	540,3	311,9
ENR 100-200/75	75	100	IE2	93,2	94,5	94,1	79,69	-	127,8	73,8	-	1022,4	590,3
ENR 100-250/30	30	40	IE2	91,3	92,3	92,4	32,50	-	53,3	30,8	-	357,1	206,2
ENR 100-250/37	37	50	IE2	91,6	92,9	92,8	39,91	-	64,0	37,0	-	403,2	232,8
ENR 100-250/45	45	60	IE2	92,8	93,3	93,2	48,28	-	78,3	45,2	-	540,3	311,9
ENR 100-250/55	55	75	IE2	92,9	93,8	93,7	58,67	-	94,1	54,3	-	752,8	434,6
ENR 100-250/75	75	100	IE2	93,2	94,5	94,1	79,69	-	127,8	73,8	-	1022,4	590,3
ENR 100-250/90	90	120	IE2	94	94,3	94,4	95,33	-	151,2	87,3	-	1164,2	672,2
ENR 125-200/37	37	50	IE2	91,6	92,9	92,8	39,91	-	64,0	37,0	-	403,2	232,8
ENR 125-200/45	45	60	IE2	92,8	93,3	93,2	48,28	-	78,3	45,2	-	540,3	311,9
ENR 125-200/55	55	75	IE2	92,9	93,8	93,7	58,67	-	94,1	54,3	-	752,8	434,6
ENR 125-200/75	75	100	IE2	93,2	94,5	94,1	79,69	-	127,8	73,8	-	1022,4	590,3
ENR 125-200/90	90	120	IE2	94	94,3	94,4	95,33	-	151,2	87,3	-	1164,2	672,2
ENR 125-200/110	110	150	IE2	93,7	94,6	94,8	115,98	-	186,0	107,4	-	1432,2	826,9

NOISE DATA

Power		L _{pA} - dB(A) *
[kW]	[HP]	
0,75	1	<70
1,1	1,5	
1,5	2	
2,2	3	
3	4	72
4	5,5	78
5,5	7,5	80
7,5	10	
11	15	
15	20	81
18,5	25	
22	30	83
30	40	
37	55	85
45	60	86
55	75	88
75	100	90
90	125	92
110	150	

* Mean value of several measures at 1m distance around the pump. Tolerance ± 2.5 dB.