



EUROMAG
INTERNATIONAL

Measure > Sense > Innovate



ELECTROMAGNETIC FLOW METERS

www.fluidtechnics.nl
info@fluidtechnics.nl

+31(0)184669328

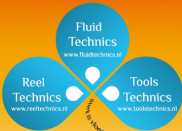

FluidTechnics
sterk in vloeierend werk

MUT 7000

Instruction manual

Version 1.0 - Ed. 01/2022

ENGLISH

Translation of the original instruction

TD-222-0-ENG

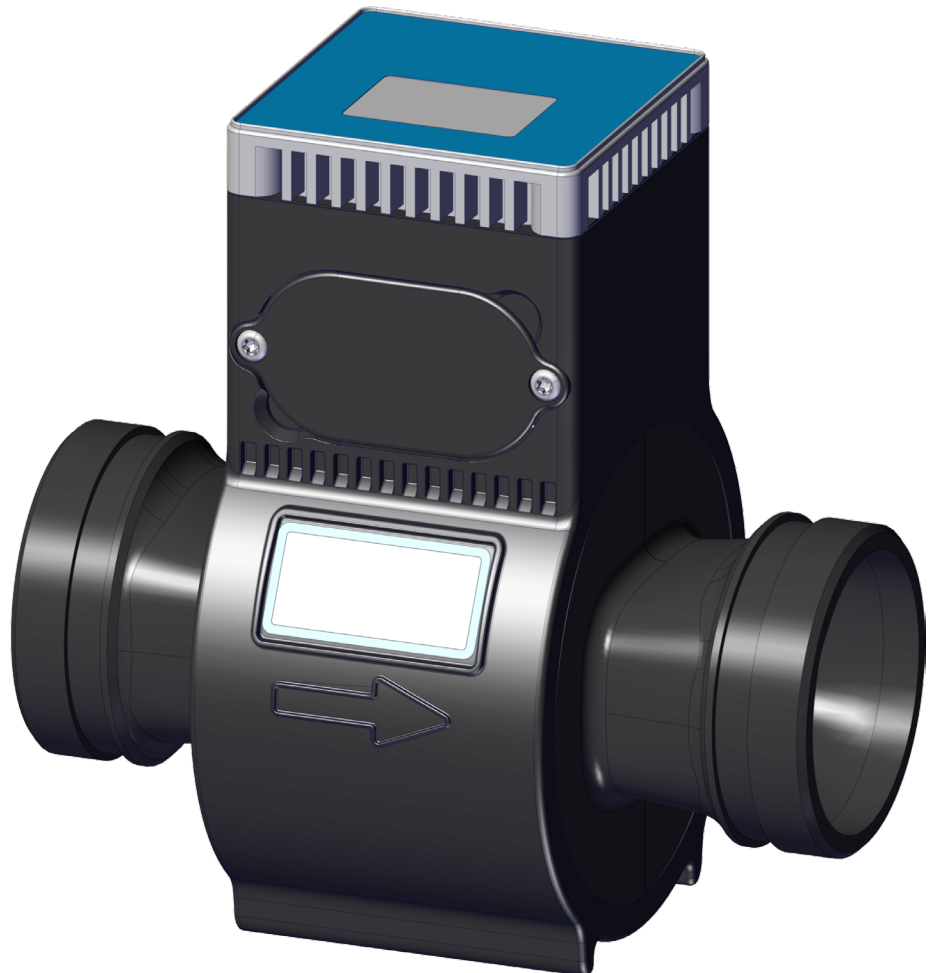

CAREFULLY READ THESE INSTRUCTIONS AND KEEP THEM IN A SAFE PLACE



Modbus





This document must be delivered to the user before machine installation and commissioning.

Symbols used in this manual

In order to draw the attention of all personnel working with the equipment supplied by EUROMAG INTERNATIONAL, the points of particular importance described in this manual are highlighted with graphic signs and different colors that will make them easily identifiable.

Legend



CAUTION! This sign indicates a risk of electric shock! All operations marked with this sign must be performed exclusively by qualified technical personnel.



CAUTION/WARNING. This symbol indicates vital information and points to be observed. Please refer to the related documents.



NOTE. This symbol indicates information and points of particular importance to be observed.

READ THE INSTRUCTIONS CAREFULLY AND KEEP THEM IN A SAFE PLACE

This manual can be downloaded from the web site www.euromag.com in the Area Download section.

We want you to save time and money!

We assure you that, having read this manual thoroughly, you will be able to perform correct installation and fully use the product in total safety.

1	INTRODUCTION	5
1.1	MANUFACTURER'S STATEMENT	5
1.2	PACKAGING VERIFICATION	5
1.3	PRELIMINARY NOTES	6
1.4	PRODUCT IDENTIFICATION	7
1.5	APPLICATIONS.....	8
2	PRODUCT DESCRIPTION	9
2.1	OPERATING PRINCIPLE	9
2.2	POWER SUPPLY	9
2.3	DATA SAFETY	10
3	TECHNICAL SPECIFICATIONS	11
3.1	OVERALL DIMENSION	11
3.2	CERTIFICATES AND APPROVALS.....	12
3.3	GENERAL TECHNICAL FEATURES	13
3.4	MEASURING ACCURACY	14
3.4.1	Reference conditions:	14
3.4.2	Accuracy class	14
3.4.3	MID Annex III (MI-001) - (Directive 2014/32/EU)	15
4	INSTALLATION	16
4.1	STORAGE AND MOVING	16
4.1.1	Storage	16
4.2	GENERAL INSTALLATION REQUIREMENTS	16
4.2.1	Vibrations	16
4.2.2	Magnetic fields	17
4.2.3	Negative pressure.....	17
4.2.4	Protection from direct sunlight	17
4.2.5	Operating temperatures	17
4.3	INSTALLATION CONDITIONS.....	18
4.3.1	Positioning in relation to the plant.....	18
4.3.2	Important guidelines for correct installation	18
4.4	INSTALLATION	22
4.4.1	Important instructions on installation.....	22
4.4.2	Sensor support.....	23
4.5	HOW TO AVOID AIR POCKETS IN THE PIPELINES	24
4.6	ELECTRICAL CONNECTION	28
4.6.1	Wiring diagram.....	28
4.6.2	Connection options I/O	30
4.6.2.1	Pulse output	30
4.6.2.2	RS485 - 2 wire interface	30
4.6.3	Electrical grounding of the meter	32
4.6.3.1	Plastic Pipe Installation using Grounding Rings	32
4.6.3.2	Metal Pipe Installation.....	33
4.6.4	Connection to the power supply.....	33
4.7	BATTERY INSTALLATION	34

5	METER PROGRAMMING	36
5.1	DISPLAY	36
5.2	FIRST ACTIVATION	37
5.3	USER INTERFACE	38
5.4	DISPLAY TEST	39
5.5	FUNCTIONS	39
5.5.1	List of functions available through display interface.....	41
5.6	BATTERY	42
5.7	ACCESS VIA MAG-NET APP	43
5.8	ACCESS VIA EUROMAG-LINK	44
5.8.1	Access via RS485.....	44
5.8.2	Access via Bluetooth.....	45
5.9	FIRMWARE UPDATE	47
5.10	DEVICE RESET	49
5.10.1	Reboot	49
5.11	METERS SUBJECT TO LEGAL METROLOGY.....	50
5.11.1	Metrological seals	50
5.11.2	Utility seals.....	50
6	MAINTENANCE	51
6.1	CABLE GLAND CLOSING AND GASKET CONDITION CHECK	51
6.2	BATTERY INSTALLATION/REPLACEMENT	51
7	TROUBLESHOOTING	52
7.1	MALFUNCTIONING AND POSSIBLE SOLUTIONS	52
7.2	SELF DIAGNOSTIC.....	53
8	SENDING THE CONVERTER TO THE MANUFACTURER	55
8.1	RETURN MERCHANDISE AUTHORIZATION.....	55
9	PRODUCT DISPOSAL	57

1 INTRODUCTION



IMPORTANT WARNING! It is very important that all personnel working with the equipment have read and understood the instructions and indications provided in this manual, and that they follow them prior to using the equipment itself. The manufacturer assumes no responsibility for the consequences resulting from improper use by the worker.

The worker will be responsible for the suitability of the device for particular purposes.

The warranty will be considered void in case of improper installation and use of devices (systems).

- The manufacturer shall bear no responsibility for any damage caused by improper use, improper installation or tampering of own products. Installation, connection, commissioning and maintenance must be carried out by personnel who are qualified and authorized for this purpose. The personnel in charge of the installation must make sure that the measurement system is properly connected as per the wiring diagram indicated in this document.
- The manufacturer shall bear no responsibility for any damages or injuries resulting from any misunderstanding of this manual. In order to avoid possible accidents to persons or things caused by incorrect interpretation of the instructions, the user must not proceed with operations and/or interventions on the meter if there are uncertainties or doubts regarding the operation(s) to be performed. We recommend contacting Assistance Service for clarifications in this regard for more precise instructions.
- The manufacturer will be held responsible only if the meter will be used in its original configuration.

For applications that require high working pressures or use of substances that may be dangerous for people, the environment, equipment or anything else: In case of pipe breakage, EUROMAG INTERNATIONAL recommends to take the necessary precautions such as adequate positioning, protection or installation of a guard or safety valve, before installing the meter.

The device contains live electrical components, therefore installation, checks and maintenance must be carried out by experienced and qualified personnel who are aware of all necessary precautions to be taken. Before opening any internal part, please disconnect the power supply.

1.1 MANUFACTURER'S STATEMENT

- » Stresses and loads possibly caused by earthquakes, strong winds, fire damage, vibrations and natural disasters were not taken into account in the phase of product designing.
- » Do not install the product in such a way that it acts as a focus for stresses on the pipes. External loads were not taken into account in the device configuration.
- » While the device is working, the pressure, supply voltage and/or temperature values indicated on the label or in this Operating Manual must not be exceeded.

1.2 PACKAGING VERIFICATION

At the moment of purchase and/or upon receipt of the product, the buyer is strongly advised to check the quality of the packaging which must be intact, without visible dents and completely and correctly closed. When opening the packaging, also check that the product complies with the information on the packing list in terms of completeness of components/accessories.



NOTE: All EUROMAG INTERNATIONAL software packages are available on the USB flash drive key that accompanies the product.

The software can also be downloaded from the website www.euromag.com by accessing the Download Area. A free registration will be required after which you can download the configuration software for your product.

1.3 PRELIMINARY NOTES

The **MUT7000** is a reduced bore electromagnetic flowmeter, made of thermoplastic material equipped with grooved connection system, available in sizes DN50/2" - DN150/6", and with an integrated electronic converter.

Like other electromagnetic flowmeters it has many important advantages compared to its mechanical counterparts, such as: exceptional long-term stability, maximum process reliability and zero maintenance. As a result, these sensors can provide accurate and reliable long-term measurements.

See the following paragraphs for more detailed information on correct installation.

Main parts of the **MUT7000** meter are:

- » Flow tube
- » Meter enclosure
- » Battery compartment
- » Label
- » Grounding stud
- » Connection cable/connector
- » Protective cover
- » Display

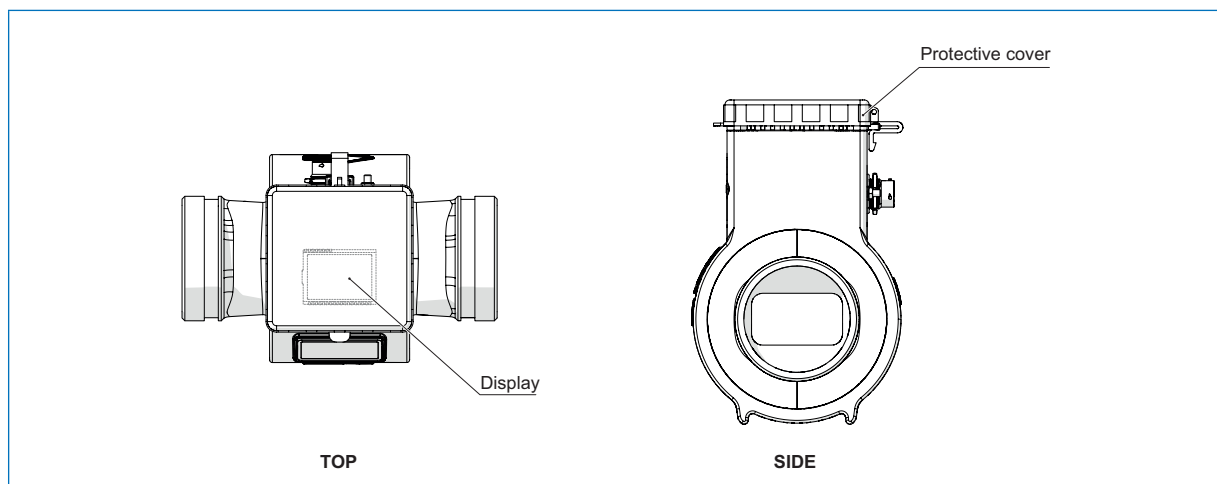
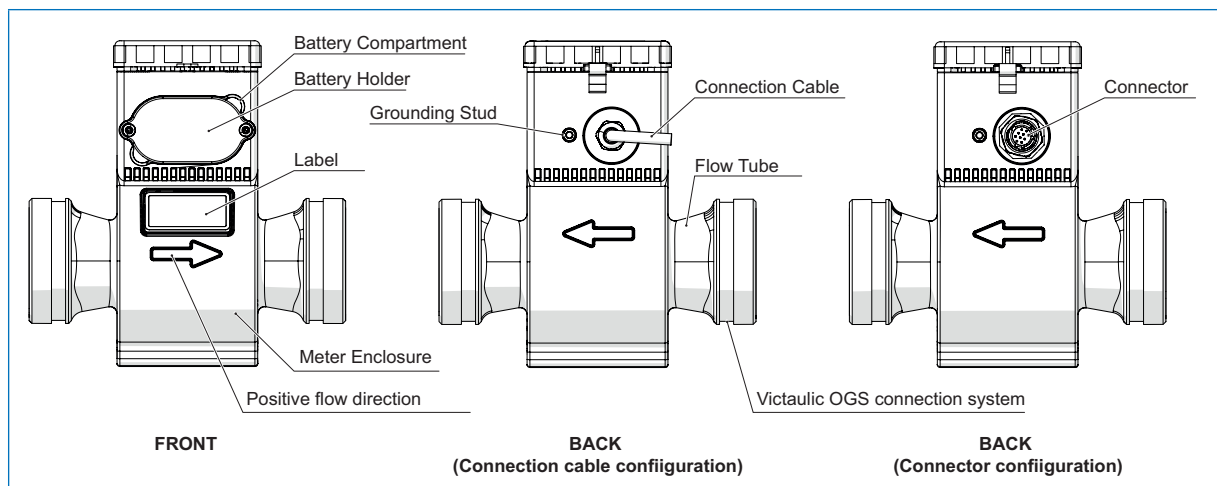

The **MUT7000** meter is equipped with a magnet for magnetic reed operation.

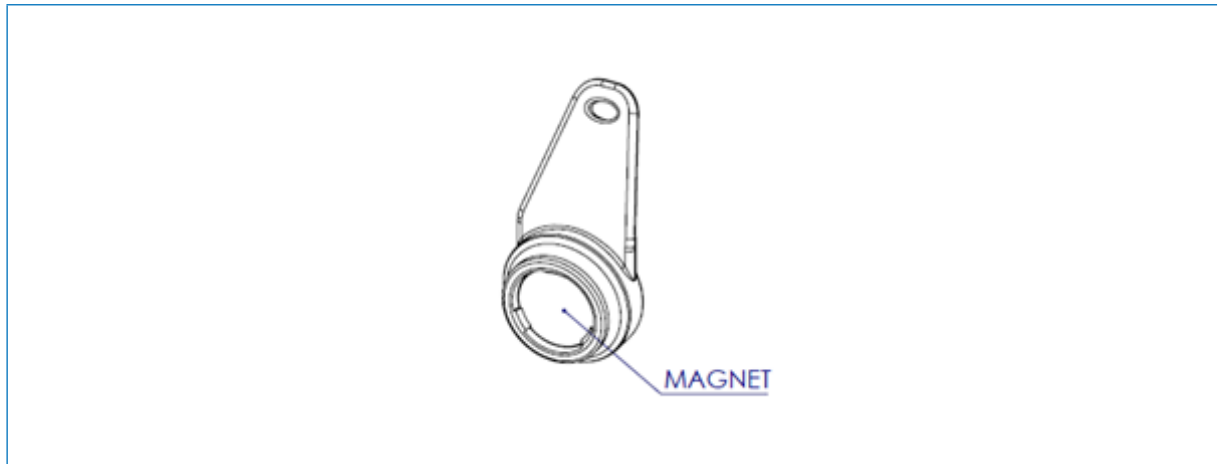

NOTES:

Electromagnetic flowmeters are designed specifically to operate under the following basic conditions:

1. The liquid must be conductive
2. The tube must always be completely full
3. The input and output distances must be according to the recommended settings
4. The grounding instructions must be followed

1.4 PRODUCT IDENTIFICATION

Each **MUT7000** manufactured by EUROMAG INTERNATIONAL has a STANDARD identification plate (Fig. 1) or MID (Fig. 2), that displays the following information:

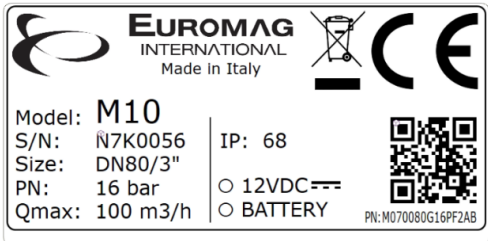
<p>STANDARD PLATE:</p> <ul style="list-style-type: none"> » CE conformity mark. » MODEL: Instrument Model » S/N: Meter Serial Number » Size: Nominal diameter » PN: Pressure class » Qmax: Max flow rate » IP: Degree of protection » 12Vdc / Battery: power supply, to be selected during commissioning » : This symbol means that the product must be disposed of according to the legal requirements. 	 <p>Fig. 1 STANDARD Identification Plate</p>
---	---

MID IDENTIFICATION PLATE:

- » **CE conformity mark**
- » **Model:** Instrument Model
- » **S/N:** Meter Serial Number
- » **DN80/3". PN16:** Nominal diameter and MAP
- » **Q3:** permanent flow rate
- » **R:** ratio
- » **Δp :** pressure loss class.
- » **M1 O:** Environmental Class
- » **E2:** Electromagnetic class
- » **T:** Non resettable totalizers
- » **P:** Resettable totalizers
- » **12Vdc / Battery:** power supply, to be selected during commissioning
- » **Rep.:** Date within battery must be replaced
- » : This symbol means that the product must be disposed of in accordance with the legal requirements.

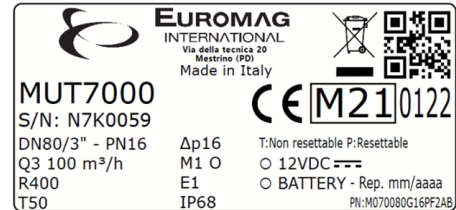

Fig. 2 MID



The identification plate must never be removed, damaged or changed. It must also be kept clean from any dirt deposits, as the data contained are the only safe and unambiguous way to recognize the type of flowmeter and it allows to complete the repair request form attached to this manual.

1.5 APPLICATIONS

MUT7000 is widely used for purposes in which it is important to measure the flow rate of electrically conductive liquids. Examples of typical applications for the **MUT7000** meter are:

- » Irrigation
- » Greenhouses
- » Waterworks
- » DMA District Metered Areas
- » Leak detection systems
- » Remote applications without access to electrical grid
- » Building and Cooling Systems

2 PRODUCT DESCRIPTION

2.1 OPERATING PRINCIPLE

MUT7000 has been designed with the aim of fulfillment of all the requirements of modern water management systems, through a flexible and hybrid electronics which, depending on the model, offers various power supply solutions.

An electromotive force is induced at the ends of a conducting fluid that moves with velocity v in a magnetic induction field B and can be expressed as:

$$e = kBDv$$

Where it is:

- B** is constant by construction;
- D** is constant and represents the distance between the electrodes **E1** and **E2** (equivalent to the diameter of the flowmeter);
- v** is the fluid velocity;
- k** is the calibration constant;

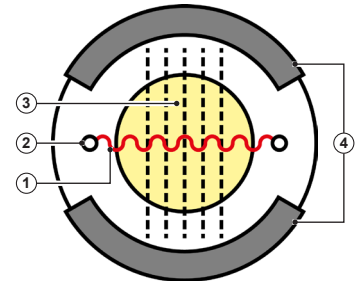

- ① - Electromotive force (proportional to the velocity);
- ② - Electrodes;
- ③ - Magnetic field;
- ④ - Coils;

emf «e» is proportional to the velocity «v»

2.2 POWER SUPPLY

The MUT 7000 meter is available with three different power supply setup:

- » Battery-powered via a lithium battery (LiSOCL2)
- » Mains powered 12Vdc ---
- » Mains powered 12Vdc with backup lithium battery

If the case of lithium battery power supply is used; it is necessary to consider the following cautions:

- » Lithium batteries are the primary energy source because of their high-energy density, and are made to meet the highest safety standards. However, they can be potentially hazardous if they are exposed to electrical or mechanical abuse. In many cases, this is associated with excessive heat production in which the increased internal pressure could lead to cell rupture.

These basic precautions need to be followed when handling and using lithium batteries:



IMPORTANT INSTRUCTIONS!

- Do not short-circuit, recharge, overload or reverse-connect the battery
- Do not expose the battery to temperatures higher than those specified, as it will incinerate
- Do not crush, puncture or open the cells or disassemble the battery packs
- Do not weld or solder the battery body or battery packs
- Do not expose the contents to water

The use of lithium batteries is regulated under the United Nations Model Regulations on the Transport of Dangerous Goods (UN Model Regulations on the Transport of Dangerous Goods), document ST/SG/AC.10/1/Rev.22.

These are basic precautions that should be followed during the transport of lithium batteries:



IMPORTANT NOTES!

- **Transport only in special packages with labels and special transport documents specific to current regulations.**
- **Be careful when handling, transporting and packing the batteries so as to avoid short-circuiting.**
- **The batteries comply with the requirements set out in the “UN Manual of Tests and Criteria, Part III, subsection 38.3” for air transport and with the provisions of the ADR regulations for transport by truck/ship.**



Remove the battery from the transmitter before sending the flow meter to EUROMAG INTERNATIONAL in case of maintenance or of any intervention under warranty.

2.3 DATA SAFETY



The MUT7000 meter guarantee the security of the collected and processed data as a result of the internal memory (EEPROM) on which the data are saved.

The integrated memory allows the storage of data with 100,000 log lines (the data are kept for more than 6 years with factory settings); when the memory is full, the new data will automatically overwrite the old data.

In order to prevent the loss of saved data, and to be able to better manage it on its management systems, the unit is supplied with a specialized software that allows users to communicate with the electronics of the MUT7000 via Bluetooth or RS485 communication interfaces, that can be connected to any PC, laptop and/or tablet with a Windows operating system, it is also possible to interface with the “Mag-Net” mobile software in iOS and Android smartphones and tablets.

Fast download, data management, easy programming and an advanced self-diagnosis system, that automatically perform a wide range of essential checks, make the MUT7000 converter a highly efficient and irreplaceable tool for fluid detection in water management systems.

A multi-level password system also allows controlled access to the data collected and guarantees confidentiality.

3 TECHNICAL SPECIFICATIONS

3.1 OVERALL DIMENSION

The overall dimensions of MUT 7000 are shown below.

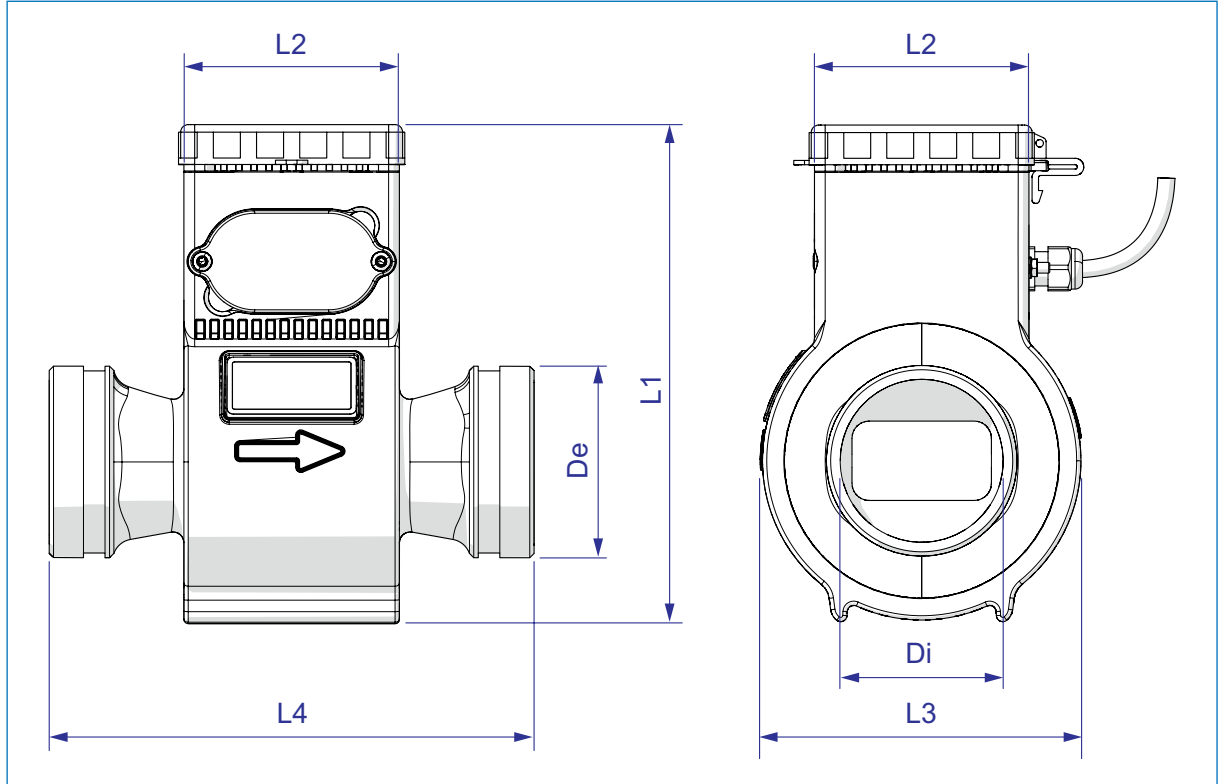

Size	De	L1	L2	L3	L4
DN50 / 2"	60.3	230	100	150	200
DN80 / 3"	88.6	230	100	150	225
DN100 / 4"	114.3	230	100	150	250
DN150 / 6" *	168.3	300	100	210	300

* DN150/6" Version are indicative

3.2 CERTIFICATES AND APPROVALS

<p style="text-align: center;">MARKING</p> 	The device complies with the requirements of the applicable EU directives. These are listed together with the applied standards in the relevant EU Declaration of Conformity.	
	Electromagnetic compatibility Directive 2014/30/EU	
	Harmonised standards:	EN 61326-1
	Radio Equipment Directive 2014/53/EU	
	Harmonised standards:	ETSI EN 301 489-1
		ETSI EN 301 489-17
	Measurement Instrument Directive 2014/32/EU	
	Harmonised standards:	EN ISO 4064 (OIML 49)
	RoHS Directive 2011/65/EU	
Harmonised standards:	EN IEC 63000	
Other certification and international standards	ISO 20456: Measurement of fluid flow in closed conduits	
	OIML R49: Water meters for cold potable water and hot water	
	OIML D11: General requirements for measuring instruments	
	EN IEC 60529: Degrees of protection provided by enclosures	
	Drinking Water Approvals: NSF 61, KTW, WRAS, ACS, DVGW W270 (Only materials, product to be evaluated)	

3.3 GENERAL TECHNICAL FEATURES

The table below contains the technical data of the MUT7000.

Features	MUT7000
Structure	<ul style="list-style-type: none"> Integral Flow meter
DN Range	<ul style="list-style-type: none"> DN50/2" ÷ DN150/6"
Nominal Pressure	<ul style="list-style-type: none"> 16 bar
Process Connection	<ul style="list-style-type: none"> Victaulic OGS
Fluid Conductivity	<ul style="list-style-type: none"> > 20 µS/cm
Process Temperature Range	<ul style="list-style-type: none"> 0 ÷ 80 °C (32 ÷ 176 °F)
Materials in contact with water	<ul style="list-style-type: none"> Flow tube: Glass fibre reinforced plastic Electrodes: AISI316L
Power supply	<ul style="list-style-type: none"> Battery Powered: 3.6 V Lithium Battery Mains Powered: 12Vdc (10.8 ÷ 13.2V), max 100mA
Consumption	<ul style="list-style-type: none"> 0,25W+1W (Mains powered)
Outputs	<ul style="list-style-type: none"> 2 passive outputs (1 programmable), SSR Type (dry contact), galvanically insulated Max. load +/- 35VDC, 100 mA protected against short circuits, minimum pulse duration 5ms. RS458 2 wire /half-duplex
Communication	<ul style="list-style-type: none"> Modbus RTU Slave Bluetooth
Display	<ul style="list-style-type: none"> LCD Segment display, with dedicated status icons, 8+6 digits
User Interfaces	<ul style="list-style-type: none"> Magnetic reed Bluetooth Mobile App Euromag Link Software
Process memory	<ul style="list-style-type: none"> 100,000 data lines Programmable frequency 1 ÷ 120 minutes (15 minutes factory standard)
Metrological certificate	<ul style="list-style-type: none"> OIML R49-1:2013 / MID 2014/32/EU - Class 2 (if requested)
Temperature range	<ul style="list-style-type: none"> Ambient: -20 ÷ 60 °C (-4 ÷ +140 °F) Process: 0 ÷ 80 °C (32 ÷ 176 °F) Storage: -40 ÷ 70 °C (-40 ÷ +158 °F)
Technical units	<ul style="list-style-type: none"> m, m3, l, ML, ft3, gal
Totalizers	<ul style="list-style-type: none"> 5 (2 Positive, 2 Negative, 1 Net)
Alarms and status icons	<ul style="list-style-type: none"> Status icons displayed and alarms recorded in the data logger
Self diagnostic	<ul style="list-style-type: none"> Excitation failure Excessive ambient temperature Wet electronic board Low battery level / Mains voltage out of range Pulses overlapping Bluetooth communication error Empty pipe Measurement error Software/memory malfunction Mains power interruption
Software for communication and programming	<ul style="list-style-type: none"> Bluetooth Mobile App - Mag-Net Euromag Link Software (through Bluetooth dongle, or RS485 interface)
Data Protection	<ul style="list-style-type: none"> Customizable password protection EEPROM Memory with safe data storage management

3.4 MEASURING ACCURACY

3.4.1 Reference conditions:

• Measuring liquid: water
• Conductivity: >200 $\mu\text{s}/\text{cm}$
• Temperature: 20°C
• Pressure: 1 bar / 10Mpa
• Upstream diameters: $\geq 5 \text{ DN}$
• Downstream diameters: $\geq 3 \text{ DN}$

3.4.2 Accuracy class

ISO 20456:	Q1÷Q2: $\pm 0,45\text{mm}/\text{s}$ Q2÷Q4: $\pm 0,5\% \pm 0.35\text{mm}/\text{s}$
ISO 4064/OIML R49:	R400 - Class 2

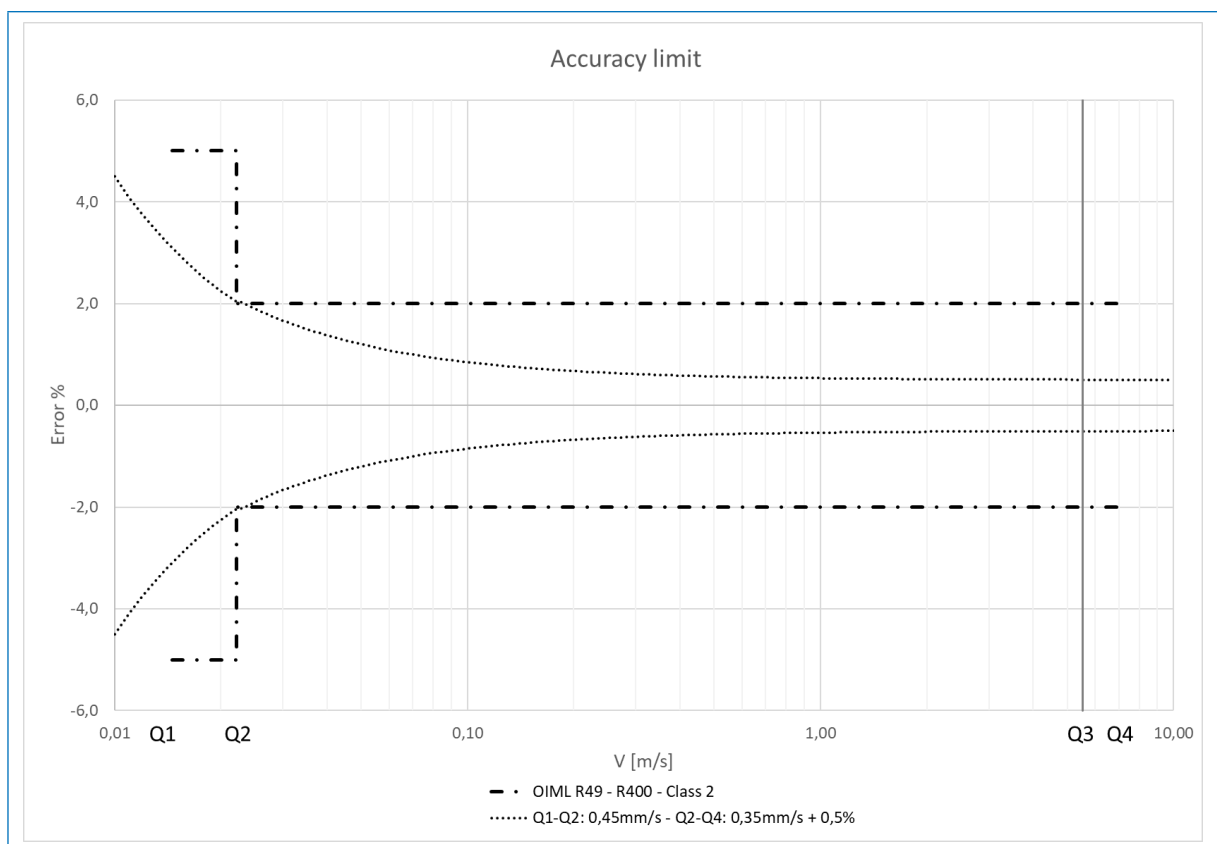

3.4.3 MID Annex III (MI-001) - (Directive 2014/32/EU)

Flow characteristics

Size	Ø In and Outlet [mm]	Flow rates [m ³ /h]				
		Minimum Q1	Transitional Q2	Permanent Q3	Overload Q4	Ratio Q3/Q1
DN50 / 2"	50	0,10	0,16	40	50	400
DN80 / 3"	80	0,25	0,40	100	125	400
DN100 / 4"	100	0,40	0,64	160	200	400
DN150 / 6"	150	1,00	1,60	400	500	400

Water temperature class

- » T50 (+0,1 °C / +50 °C)

Maximum admissible pressure (MAP)

- » 1,6 MPa (16 bar)

Orientation limitation

- » The sensor can be used in horizontal, vertical or diagonal position.

Flow profile sensitivity class

- » U0 and D0 (0 x DN upstream and 0 x DN downstream)

Reverse flow

- » The water meter is designed to measure reverse flow. The reverse flow is recorded on a separate volume totalization. Also for reverse flow another pulse output is used.

Pressure loss class

- » Δp 16 (0,016 MPa or 0,16 bar)

Temperature range ambient

- » 0°C/+55°C

4 INSTALLATION

4.1 STORAGE AND MOVING

4.1.1 Storage

i To ensure the correct maintenance of the device while waiting for its installation, it is necessary to comply with the storage provisions below:

- 1) Store the device in a dry place and protected from dust
- 2) Keep away from direct and continued sunlight
- 3) Keep the device in the original packaging until it is used
- 4) Temperature of the storage place: $-40 \div +70 \text{ }^{\circ}\text{C}$ ($-40 \div +158 \text{ }^{\circ}\text{F}$)

4.2 GENERAL INSTALLATION REQUIREMENTS

i **IMPORTANT NOTE! THE SENSOR MUST ALWAYS BE COMPLETELY FULL OF LIQUID!**



Fig. 3 The pipe must always be completely full of liquid

4.2.1 Vibrations

- DO NOT expose the flowmeter to vibrations and/or movements that could affect its performance and duration.

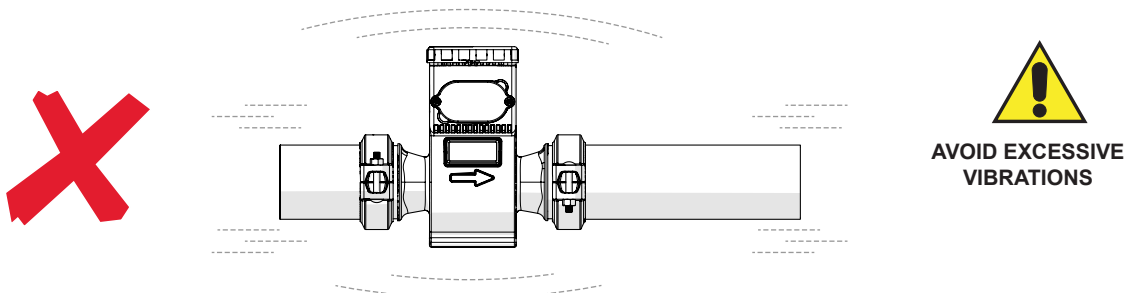

Fig. 4 Avoid vibrations

- Install a suitable anti-vibration protection if vibrations occur.

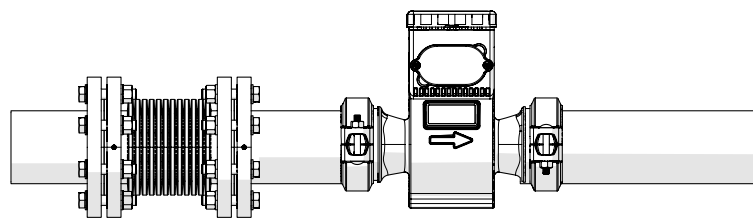

Fig. 5 Installation with anti-vibration protections

4.2.2 Magnetic fields

- AVOID exposing the flowmeter to strong or nearby magnetic fields.

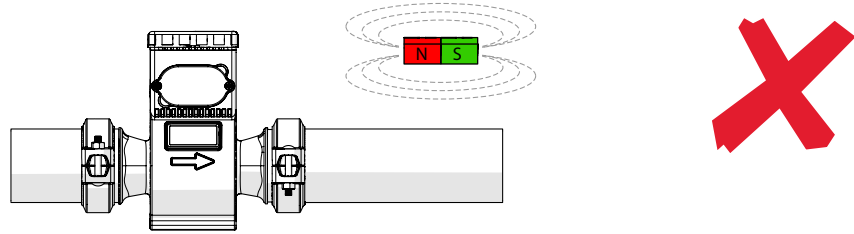

Fig. 6 Avoid magnetic fields

4.2.3 Negative pressure

- i Avoid vacuum conditions in the pipe. They can damage the coating of the flowmeter and move the electrodes from their correct position.

4.2.4 Protection from direct sunlight

- Protect the flowmeter if exposed to direct sunlight.

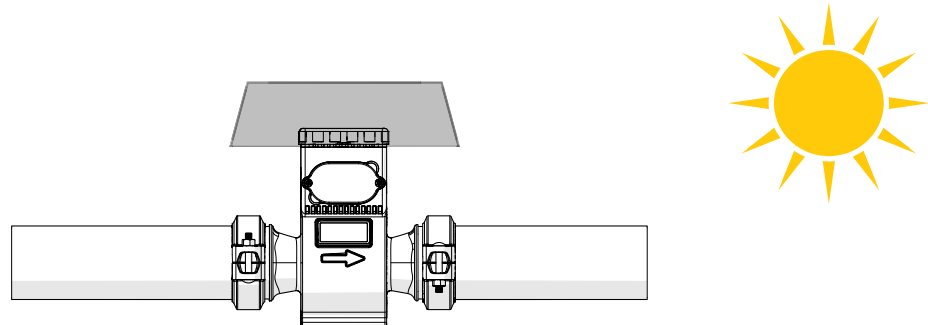

Fig. 7 Avoid direct exposure to sunlight

4.2.5 Operating temperatures

- For normal and efficient operating of the flowmeter:
 - » The ambient temperature must be limited within the range of $(-25 \div +60) ^\circ\text{C}$, $(-13 \div +140) ^\circ\text{F}$.

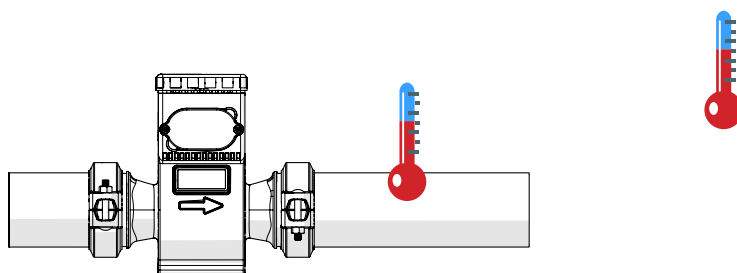

Fig. 8 Environment and fluid temperature limits

- » The process temperature must be limited within the range of $(0 \div +80) ^\circ\text{C}$, $(32 \div +176) ^\circ\text{F}$.

4.3 INSTALLATION CONDITIONS

4.3.1 Positioning in relation to the plant

- To ensure optimal working conditions, the flowmeter must be installed correctly inside the system. Correct and incorrect installation positions are described and illustrated below.**

The flowmeter must remain below the hypothetical blue line (piezometric level line), which connects the two levels of fluid to be measured (Fig. 9).

- NOTE: Avoid placing the flowmeter above the piezometric level line (Fig. 10).**

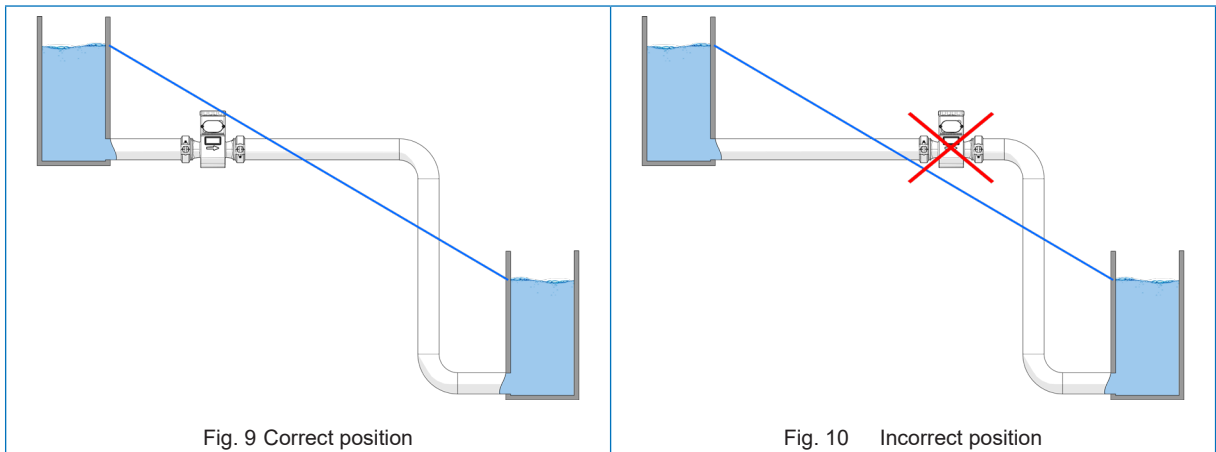

4.3.2 Important guidelines for correct installation

- The MUT7000 meter is designed to have the IP68 protection degree only when properly closed and tightened. The manufacturer does not assume any responsibility for an improper closing by third parties.**

For correct working conditions, please follow the important guidelines shown in the following figures. Improper installation may result in an inaccurate measurement.

For partially filled pipes or with downward flow and free exit, the flowmeter should be placed in a U-shaped tube (Fig. 11).

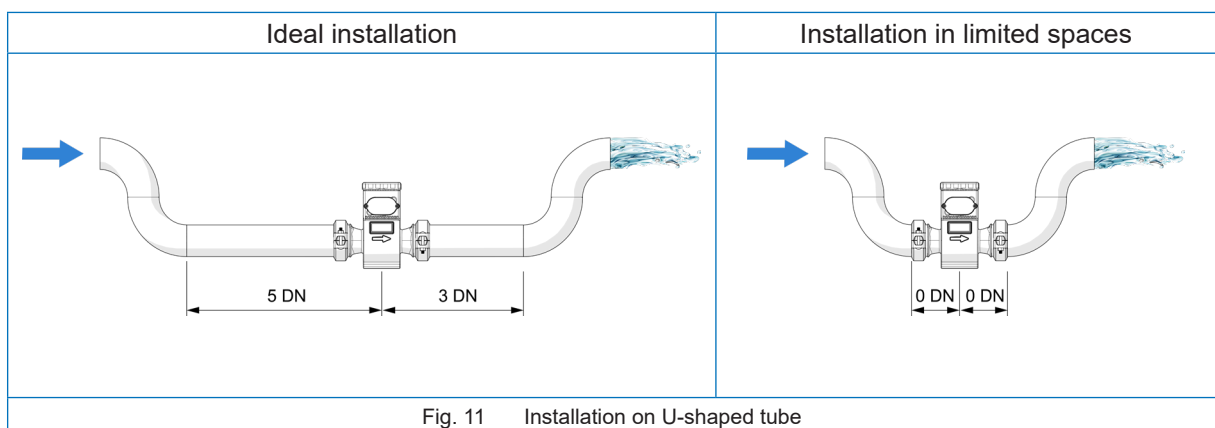

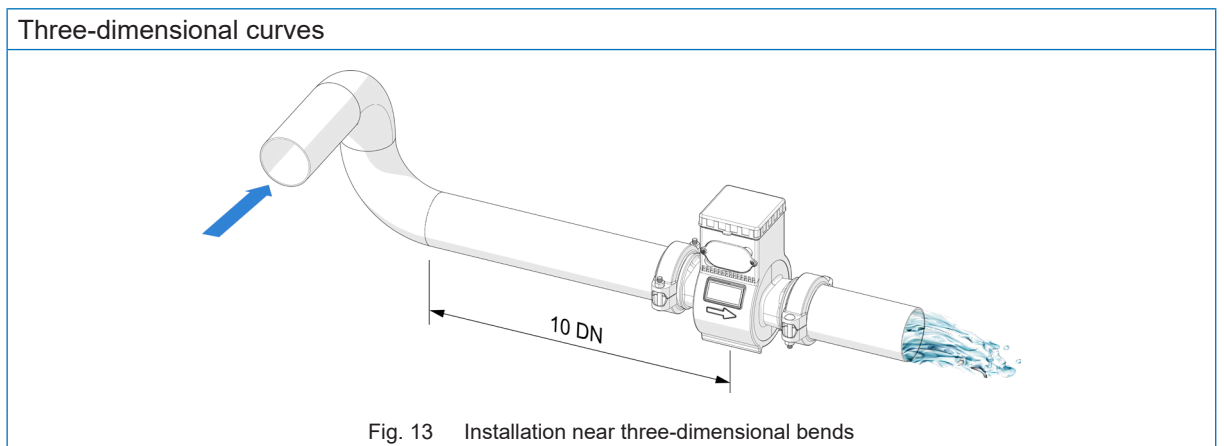
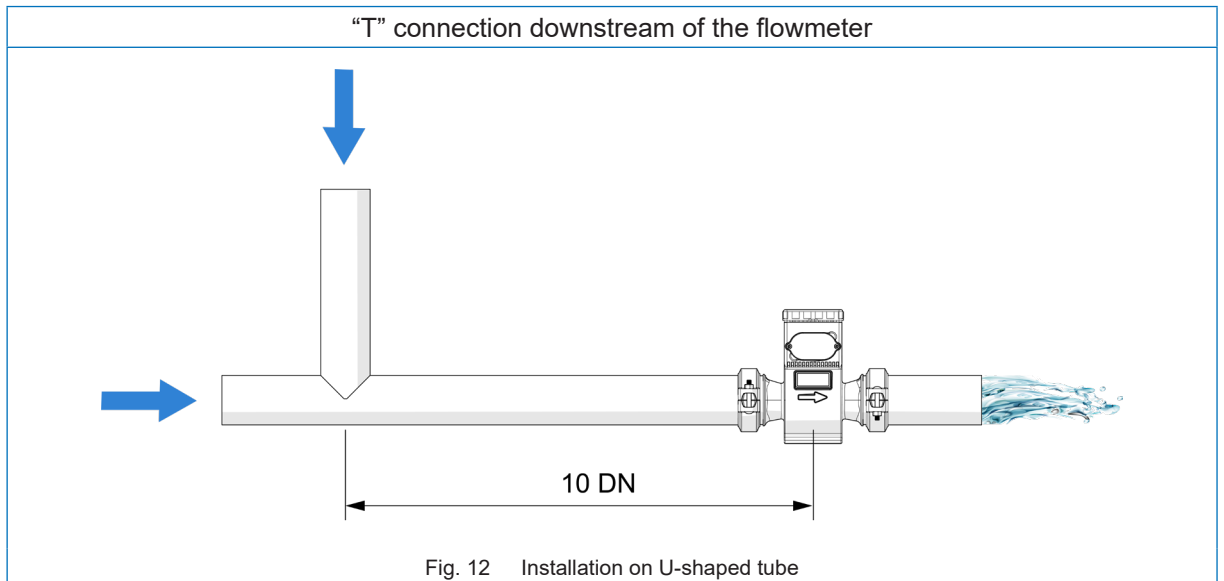

IMPORTANT NOTE: THE SENSOR MUST ALWAYS BE COMPLETELY FULL OF LIQUID!

To ensure that the sensor is always completely filled with liquid, it is important to install it in the correct position (✓) and avoid all possible incorrect positions (✗).

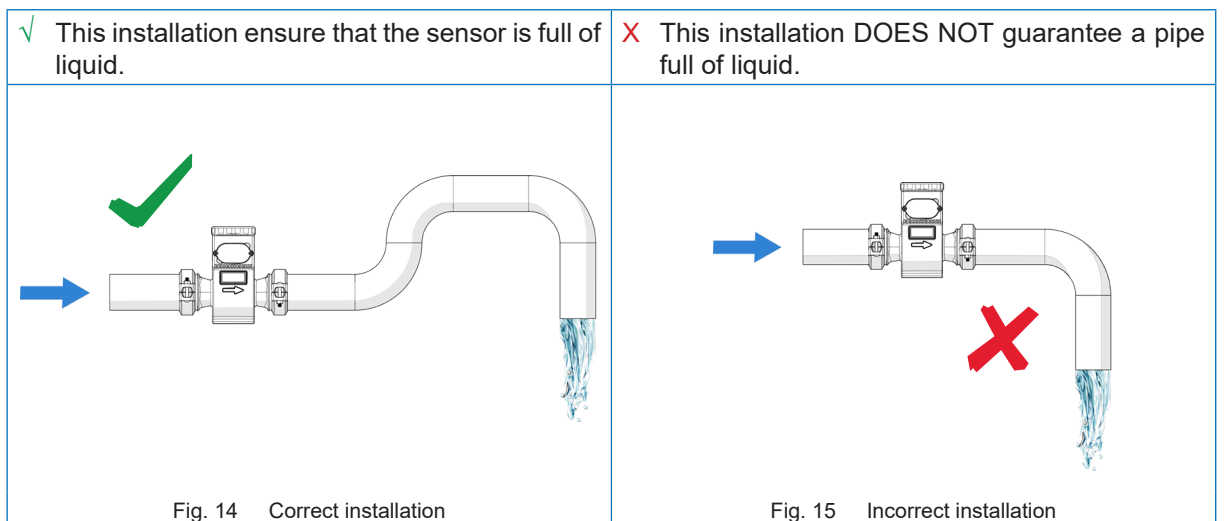

We recommend installing the sensor on a vertical/sloped pipe with an upward flow direction (Fig. 16) to minimize the wear and deposits in the sensor. Avoid the installation on vertical pipes with free exit (Fig. 17).

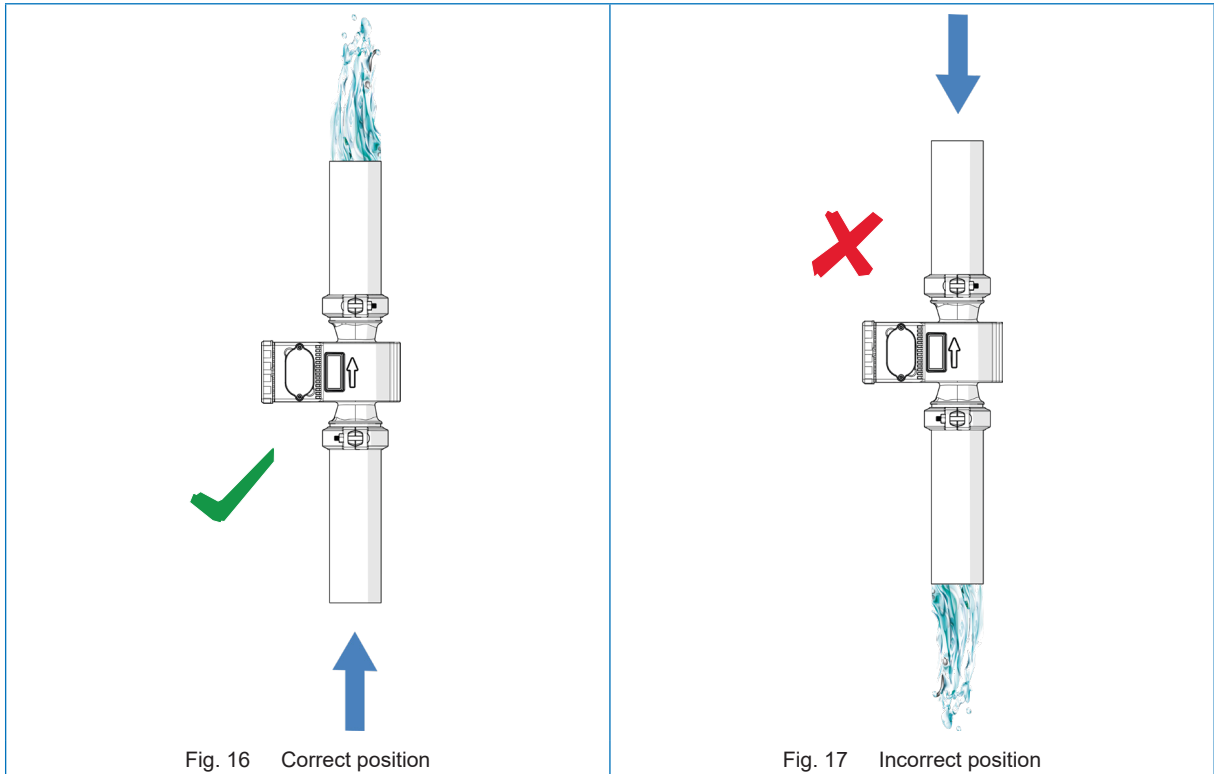

✓ The position on the left ensure that the sensor is full of liquid.

✗ Central and right positions DO NOT guarantee a pipe full of liquid.

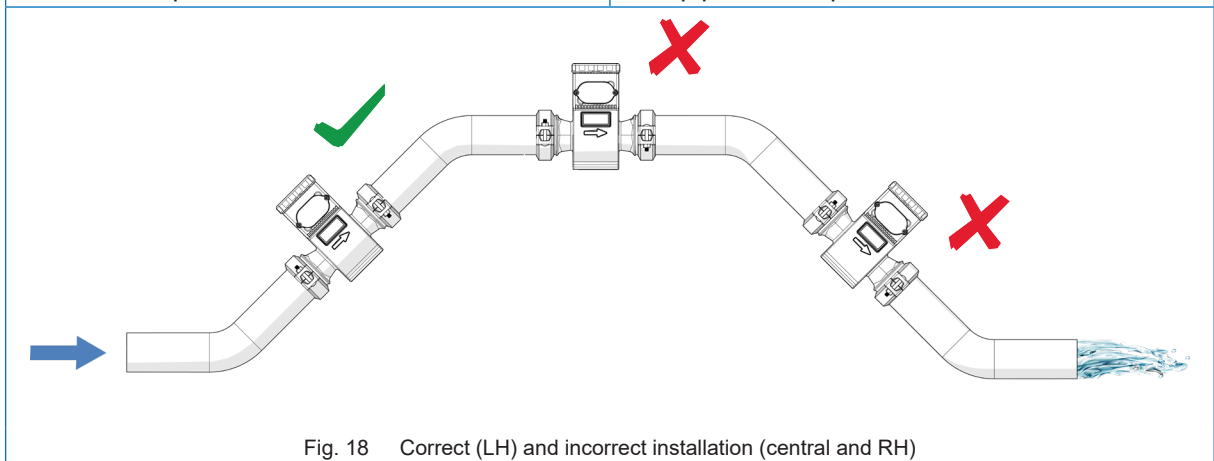

We recommend installing gate valves downstream of the meter.

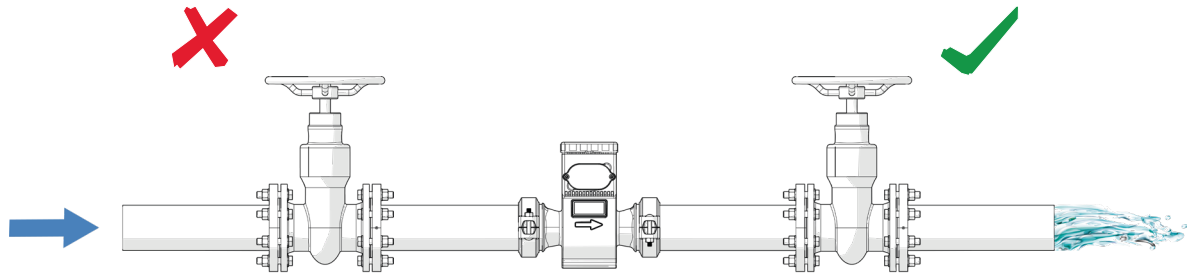

Fig. 19 Gate valves installation

✗ In order to avoid a vacuum, always install the sensor downstream of the pump and NEVER upstream.

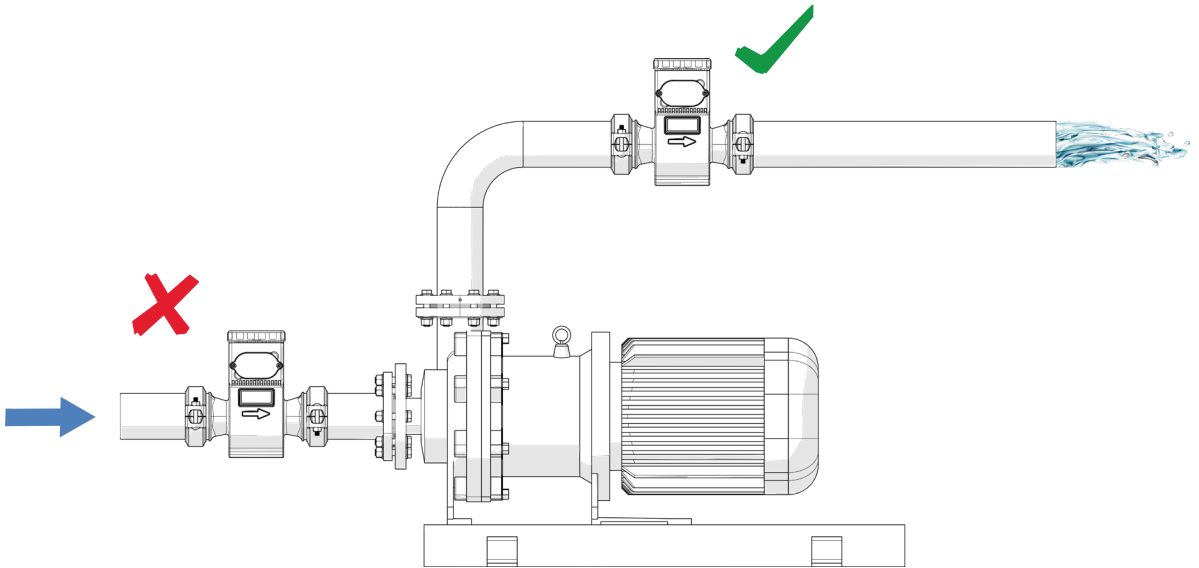

Fig. 20 Avoid negative pressure

✗ DO NOT install the sensor on vertical pipes with a free outlet or at the highest point of the pipe system.

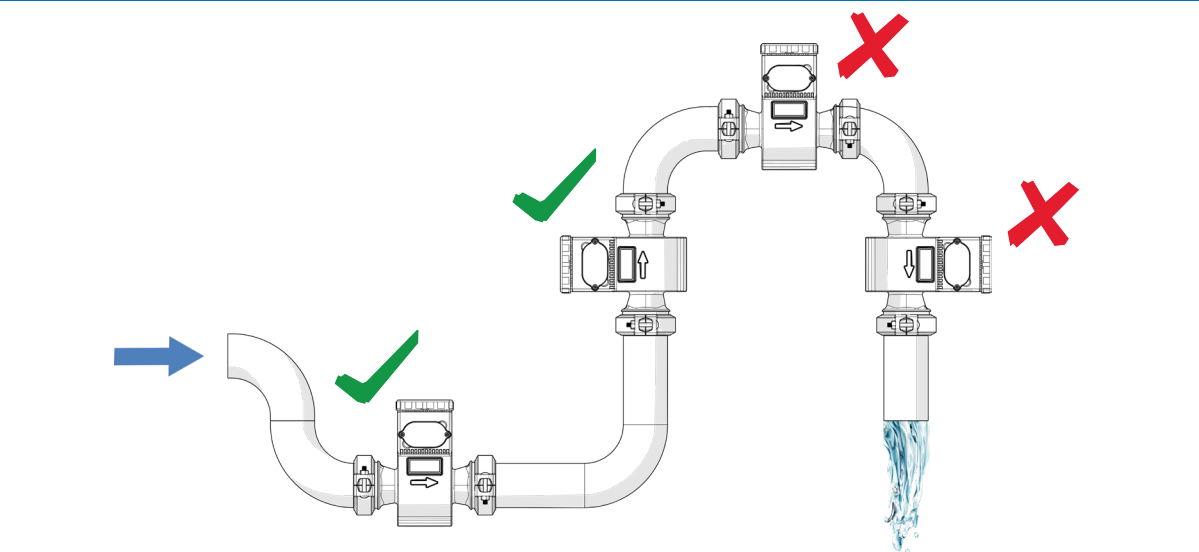

Fig. 21 Incorrect installation

4.4 INSTALLATION

4.4.1 Important instructions on installation

In case of inadequate distance between the sensor and the pipe, use elastic pipe fittings (Fig. 22). Do not try to move the pipe closer to the sensor by tightening the bolts (Fig. 23).



Do not try to move the pipe closer to the sensor by tightening the bolts.

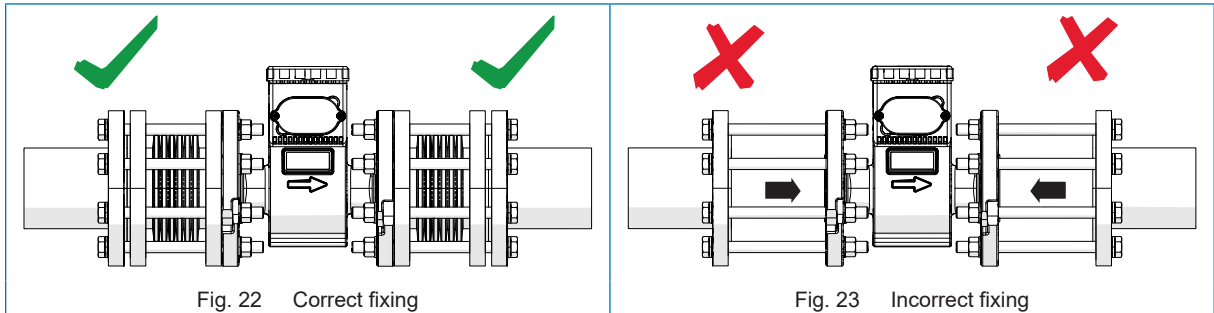

Also avoid the following positions (*):

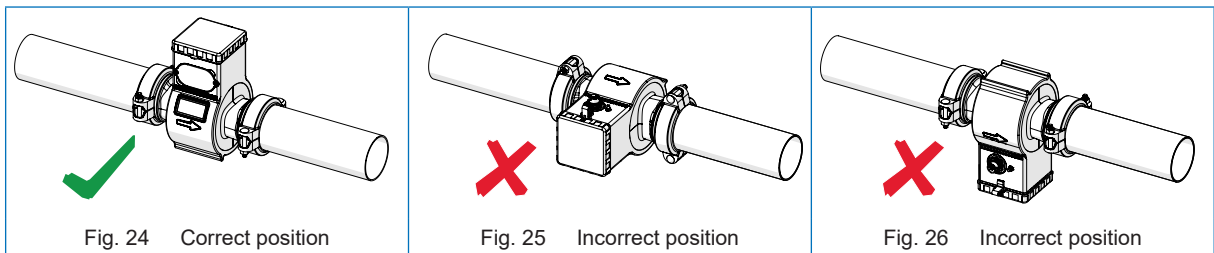

(*): **Note: Insertion meters can also be installed horizontally.**

Maximum allowable deviation of the pipe flange faces is 0.5 mm.

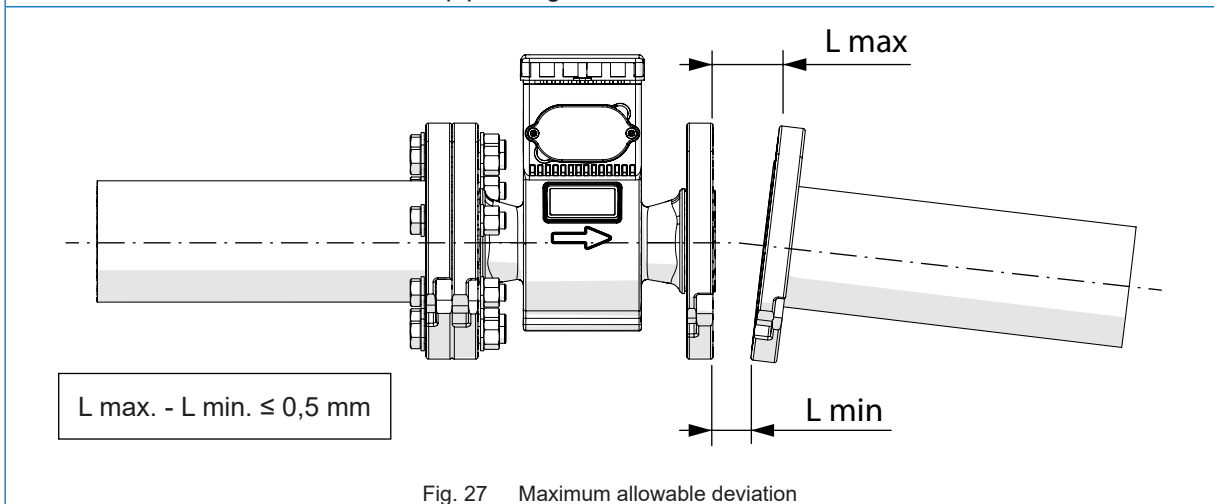

4.4.2 Sensor support

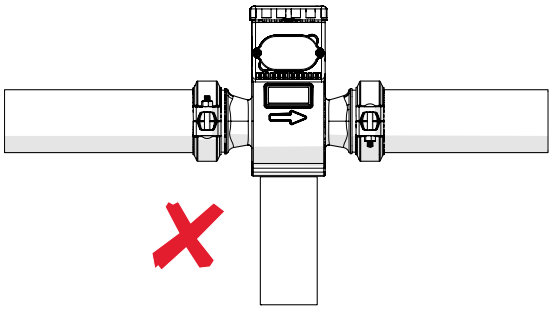
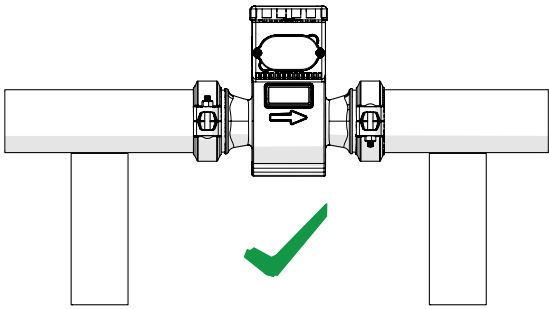
<p>✗ DO NOT USE the sensor as a support for the pipe.</p>	<p>✓ The pipe must be the support for the flowmeter.</p>
 <p>The diagram shows a cross-section of a flowmeter installed on a pipe. The flowmeter is mounted on top of the pipe, and the pipe is supported by a vertical bracket underneath. A large red 'X' is placed below the flowmeter, indicating that this installation is incorrect because the sensor is being used as a support for the pipe.</p>	 <p>The diagram shows a cross-section of a flowmeter installed on a pipe. The pipe is supported by two vertical brackets, one on each side, underneath. The flowmeter is mounted on top of the pipe. A large green checkmark is placed below the flowmeter, indicating that this installation is correct because the pipe is supported by the brackets and is not relying on the flowmeter for support.</p>
<p>Fig. 28 Incorrect installation</p>	<p>Fig. 29 Correct installation</p>

4.5 HOW TO AVOID AIR POCKETS IN THE PIPELINES

This paragraph is intended to help the designers and users of electromagnetic flowmeters to create the best installation layout that guarantees optimum performance of the meter, taking into particular consideration the problem of the presence of air pockets in the pipe.

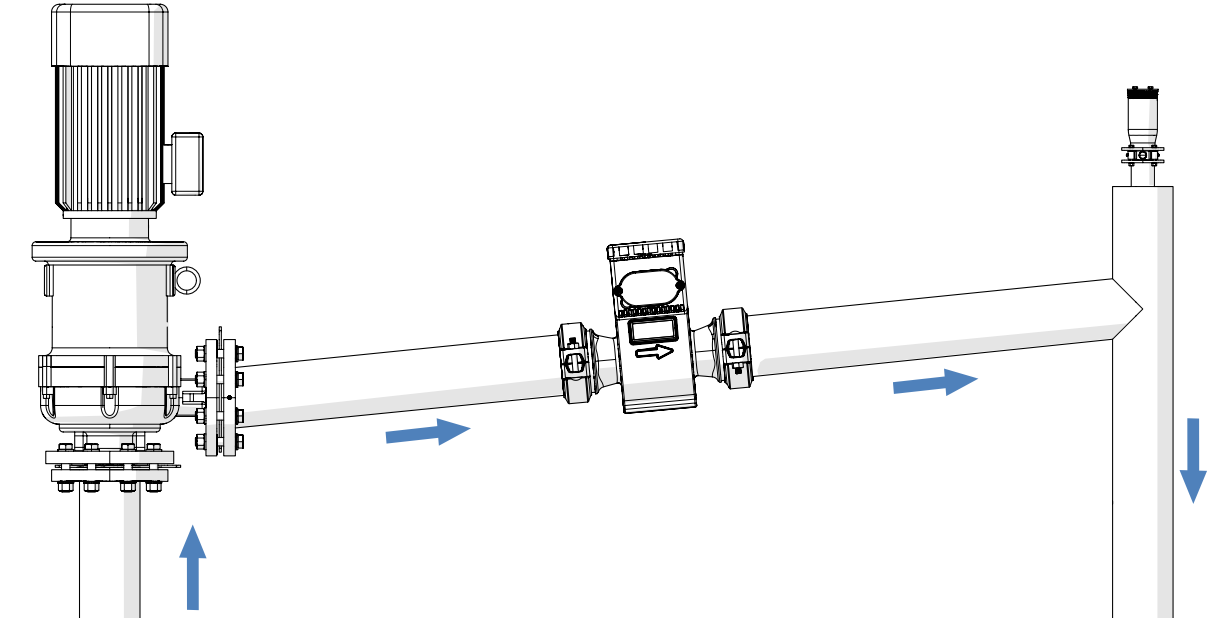

Fig. 30 Pumping stations with flowmeters and vent valves

i What are the problems caused by the air pockets entrapped in any flowmeter?

The presence of air pockets can cause serious reading errors or strong instability. In this case, the flowmeter could go into Error mode.

i How are air pockets removed, or moved away from the flowmeter?

The air pocket inside a pipe always moves toward the top of the pipe, and it is assumed that the air will always move if the flow passes along a horizontal pipe, but this is not the case. Instead, a specific water speed is required to move the air; the greater the diameter of the pipe, the higher the airspeed is required to move it away from the flowmeter.

Typically, most installations of flowmeters are simply sized on the diameter of the tube or on the flow rate in the pipe, which means that the speed is often less than 0.5 m/s, which can be very problematic if the air pockets occur.

As an example in a pipe with zero gradients, these are the specific water speeds necessary to move away the air pockets detected in the tube:

- DN50 → 0.4 m/s
- DN150 → 0.7 m/s
- DN300 → 1 m/s
- DN600 → 1.5 m/s



Fig. 31 Air pockets inside the pipe

The greater the diameter of the pipe, the higher the speed of the liquid will be required to move the air pockets away from the flowmeter.

It is also important to understand what kind of effect the water pressure has on the nature of the air pocket inside the pipe. The lower the pressure in the tube, the greater the size of the air pocket is, and the greater the effect it will have on the performance of the flowmeter. By increasing the pressure in the duct, the air pocket will compress, causing fewer problems.

This can be achieved by installing pressure control valves after the flowmeter to maintain constant pressure in any situation.

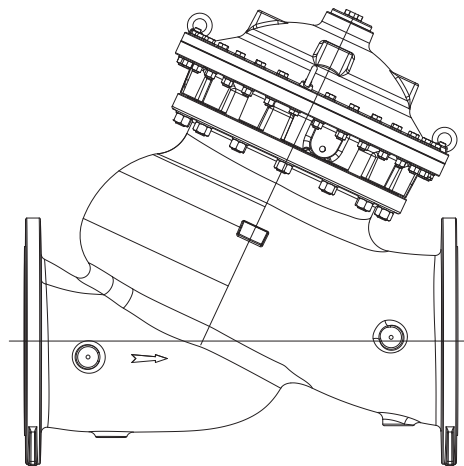

Fig. 32 Example of pressure control valves

One solution is to install the flowmeter on a pipe with an increasing slope so that the entrapped air pocket will move to the highest point. Then, through special vent valves, the air will be released from the pipe, maximizing the system capacity.

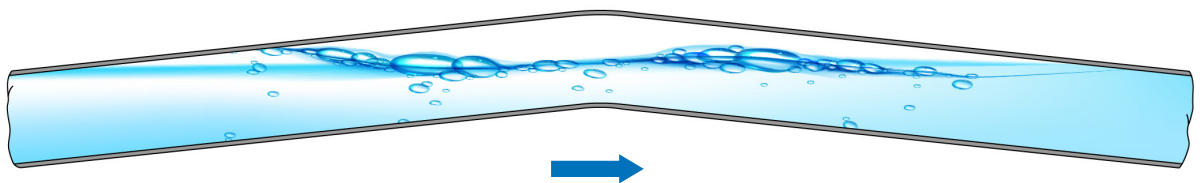

Fig. 33 Pipe with an increasing slope for application of vent valves

A minimum slope in an ascending flow of 1: 500 or higher is recommended in order to stimulate the entrapped air pocket to move away from the meter.

Drawings are made with an exaggerated slope for clarity

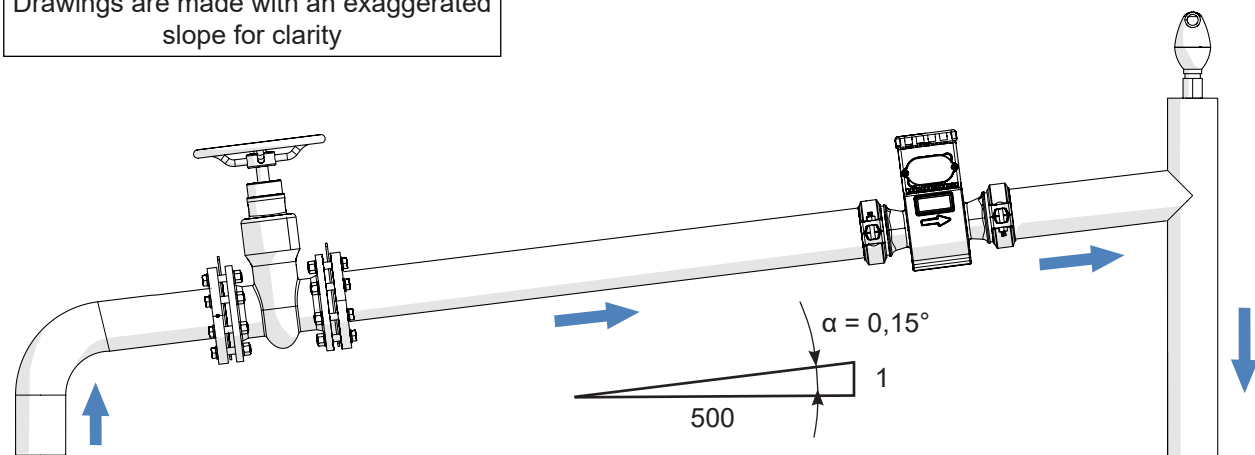

Fig. 34 Flowmeter with slight ascending slope with air vent at the top

A second solution is to mount the flowmeter vertically with an upward flow stream, which ensures that the air always moves quickly past the meter.



Importance of air vent valves.

The general principle of each installation is to ensure that the device is always full of water; however, this is not always possible since a part of the network could drain when the pumps are turned off.

It is, therefore, essential to ensure that the design incorporates a properly designed and sized air vent valve to release the air when the pump starts, making sure that the meter immediately starts reading.

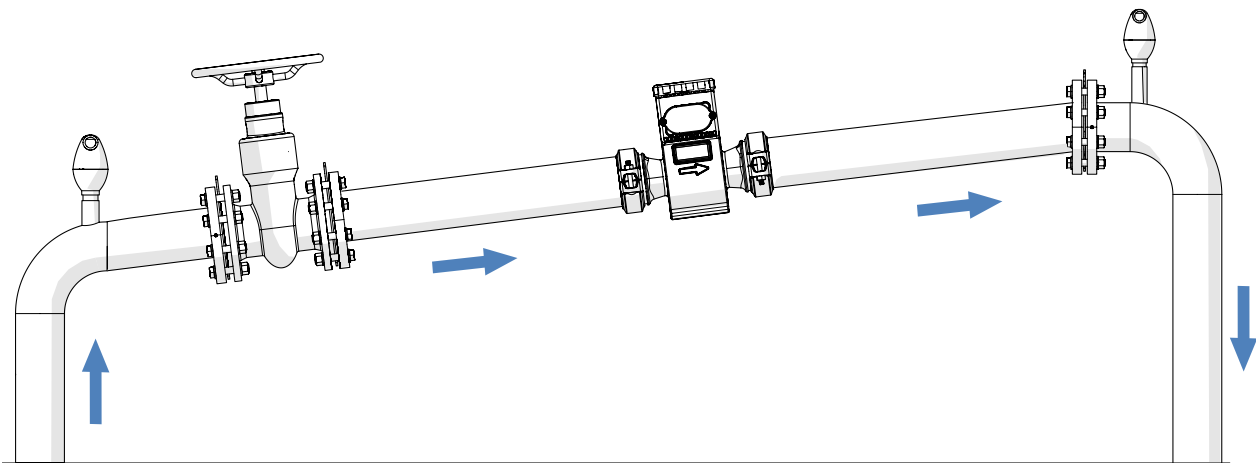

Fig. 35

The design of the vent valve is essential to ensure that the entrapped air pockets are released. Pneumatic valves or vacuum switches should be avoided. Instead, it is preferable to use combined pneumatic valves that incorporate an automatic orifice, as well as a large kinetic orifice. These valves ensure that the largest volumes of air are released quickly and effectively while filling the pipe.

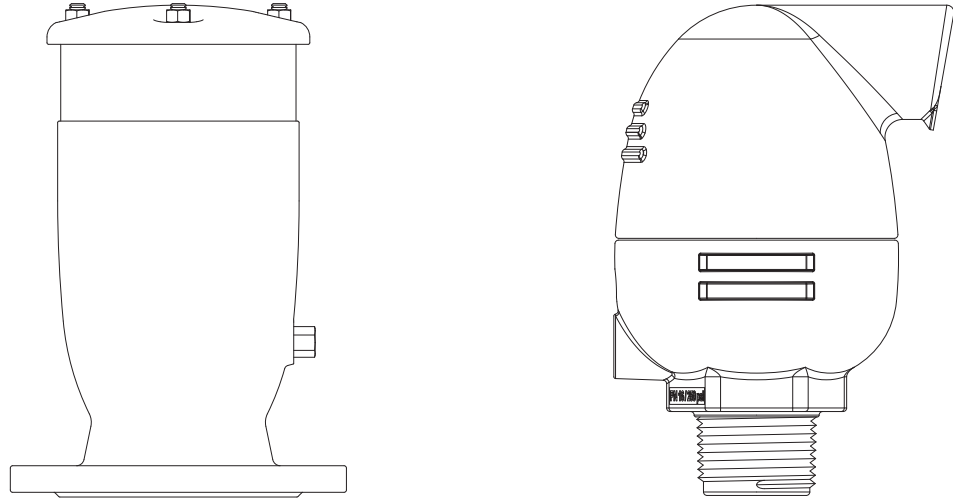





Fig. 36 Typical combined air vent valve, designed with automatic and kinetic air release functions

4.6 ELECTRICAL CONNECTION

-  In order to properly connect electrical elements of the MUT7000 meter to the power supply and I/O connections please refer to the wiring diagram shown in paragraph 4.6.1 (Fig. 38).
-  The use of cables not supplied or certified by Euromag International may jeopardize the correct functioning of the system, and it will void the warranty.
-  All interventions on electrical connections must be performed only when the device is disconnected from the mains and/or battery.

MUT7000 meter is available with 2 different connection option:

- 2m preinstalled shielded cable
- 8 pin connector (optional cable is available as accessory)

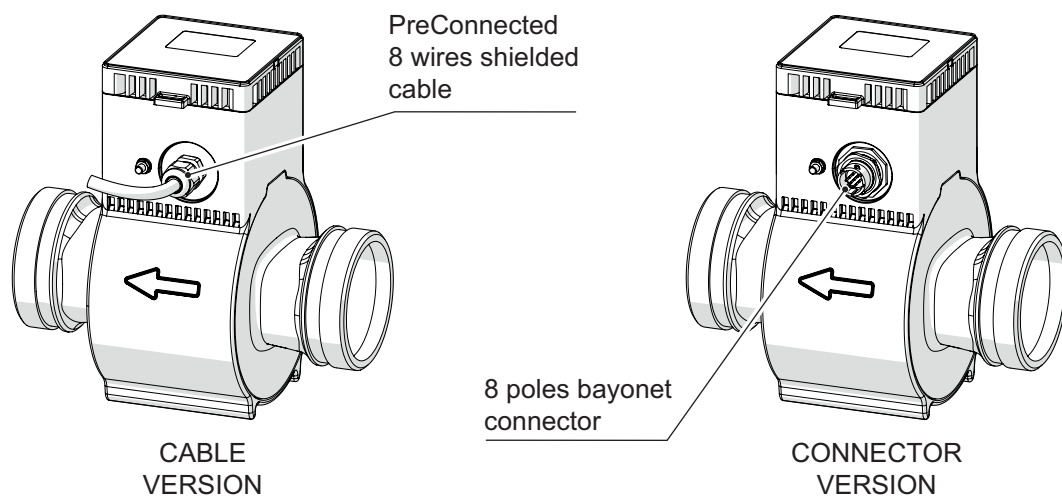

Fig. 37 Connection option

4.6.1 Wiring diagram

-  All interventions carried out on the electrical junction box or electrical components must be performed by properly trained specialized personnel.

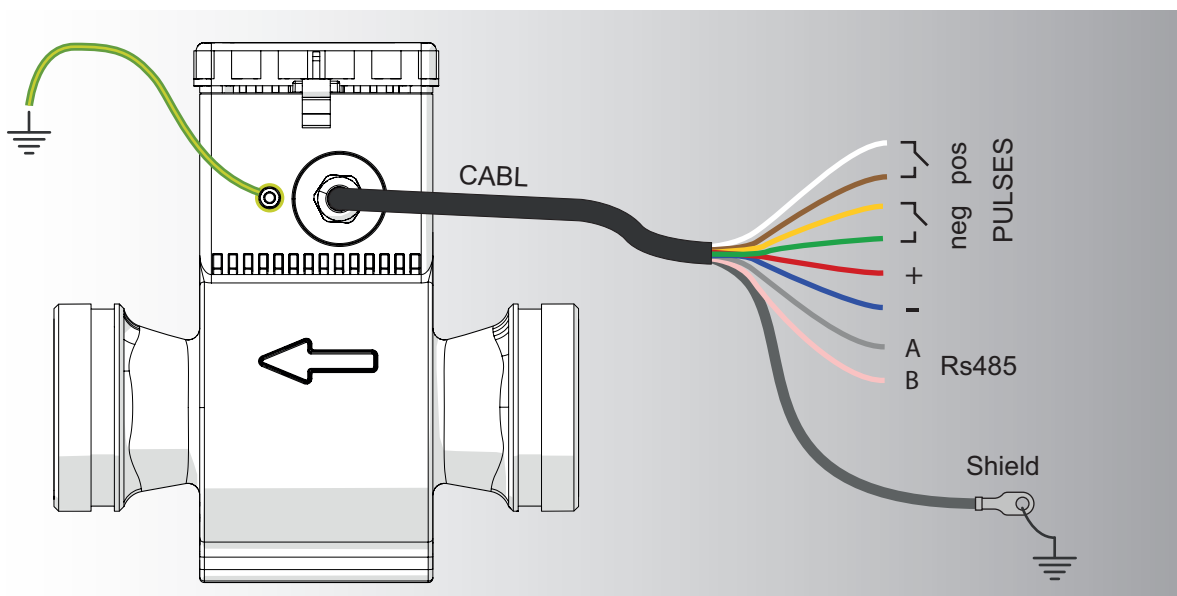

Fig. 38 Electrical Wiring

i The manufacturer has identified all the power cables and signal cables that have to be connected by marking them with a colour in order to ease the identification of the correct connection terminals (Fig. 38).

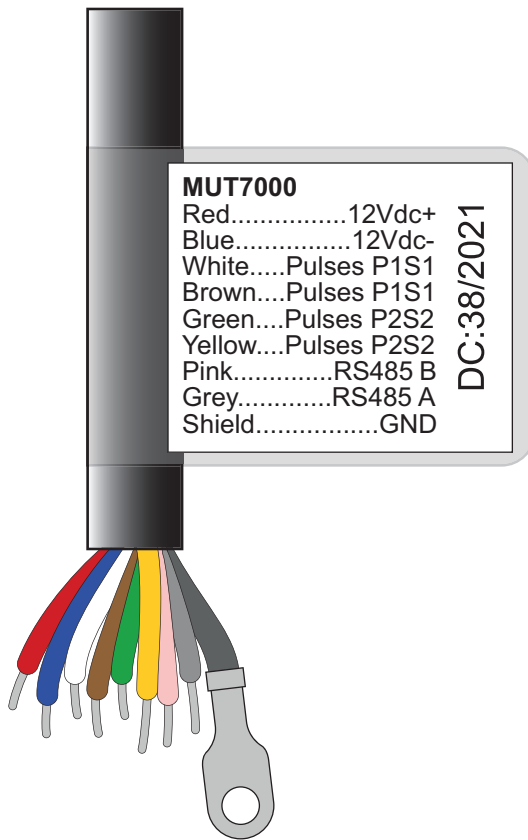

Fig. 39 Cable label

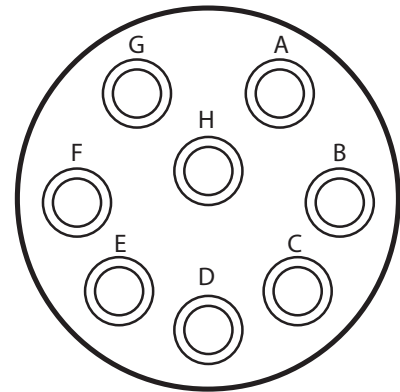

Fig. 40 Connector Pin-Out

Wire Color	Connector Pin	Function
Red	A	Supply voltage + 12Vdc
Blue	H	Supply voltage -
White	C	Pulse output 1
Brown	B	Pulse output 1
Green	G	Pulse output 2
Yellow	F	Pulse output 2
Pink	D	RS485 wire B
Grey	E	RS485 wire A
Shield	-	Shielding

Table 1 Cables and Connection Terminals Identification

Note: The cables supplied by Euromag International are not suitable for being run directly underground and/or underwater, and must not be exposed to direct sunlight. The technician in charge must therefore provide suitable protections such as: corrugated pipes, raceways, or shielded cables.

4.6.2 Connection options I/O

4.6.2.1 Pulse output

MUT7000 meter is equipped with 2 passive outputs (1 programmable) with following characteristics:

- Galvanically insulated SSR Type (dry contact)
- Max load +/- 35VDC, 100 mA, protected against short circuits
- Minimum pulse duration 5ms or max pulse frequency 100Hz

Pulse output 1:

Positive volume: generate a pulse every time the flowrate in positive direction generate a volume that exceeds the impulse volume

Pulse output 2:

Programmable by “EuromagLink” software or “Mag-Net” App

- » Negative volume
- » Positive volume
- » Error detection: 3 pulses/sec are generated if an error is detected

Pulse output is characterized by two parameters that must be set by the user according to the flow conditions in which the meter is operating

- » Pulse Volume (Vp)
- » Pulse Duration (Tp)



For battery powered meters, choose a pulse volume large enough so that the time interval between two consecutive pulses is greater than 1 second in order to preserve the battery life



Avoid pulse saturation, as it may lead to pulse accumulation which should not be provided in real time considering the actual flow rate.

Calculation of the Pulse Volume (Vp) and Pulse Duration (Tp) as a function of the flow rate:

$$\begin{aligned} \text{Mains powered: } V_p &\geq 2 Q_{MAX} \cdot T_p \\ \text{Battery powered: } V_p &\geq 20 Q_{MAX} \cdot T_p \end{aligned}$$

Where Tp must be in the range from 5ms to 500ms.

4.6.2.2 RS485 - 2 wire interface

Connection available between pink (D) and grey (E) terminals which are available through the cable or connector pins, not optoisolated.

Communication protocol:	ModBUS RTU Slave
Default configuration:	Baudrate: 9600 (Max 56700) - 8N1

Current Modbus configuration can be show following instruction on paragraph: “5.5 FUNCTIONS”

Functions: from 48 to 54

or using Mag-Net app or EuromagLink software

Modbus Address Table

See document: "MUT7000 MODBUS CMD04-03" for more detailed informations on Modbus protocol configuration.



MODBUS ADDRESS	PARAMETER	UNIT	NUM. BYTES	DATA TYPE
1662	Instantaneous flow rate in fixed unit	m ³ /h	4	Float
1664	Instantaneous fluid velocity	m/s	4	Float
1666	Instantaneous flow rate in technical unit	Tech. Unit	4	Float
1668	Instantaneous flow rate in % of full scale	% FS	4	Float
1672	Positive totalizer in fixed unit	m ³	4	Float
1674	Negative totalizer in fixed unit	m ³	4	Float
1676	Partial positive totalizer in fixed unit	m ³	4	Float
1678	Partial negative totalizer in fixed unit	m ³	4	Float
1680	Positive totalizer in technical unit	Tech. Unit	4	Float
1682	Negative totalizer in technical unit	Tech. Unit	4	Float
1684	Partial positive totalizer in technical unit	Tech. Unit	4	Float
1686	Partial negative totalizer in technical unit	Tech. Unit	4	Float



The communication interface RS485 is used in combination with Euromag-Link software or with other computer systems compatible with the MODBUS RTU standard; for further information, see the MODBUS address manual.

4.6.3 Electrical grounding of the meter

The purpose of grounding is to protect the system from external electromagnetic interference and to set the measurement reference of the meter. To achieve this requirement, a clean earth connection with the lowest possible resistance is required. We recommend using at least one $\geq 4\text{mm}^2$ / AWG11 cable to make the grounding connections. If the liquid is not electrically connected to the pipes (in plastic or with internal coating) grounding rings are required. Absent or incorrect grounding will result in erratic measurement or unpredictable failure (Fig. 41).

-  **The sensor must always be grounded! An incorrect grounding may lead to an incorrect measurement.**
-  **GROUNDING CABLE: Minimum section 2.5mm^2 (recommended: 4mm^2), grounding screws M5. Recommended ground resistance value is $\leq 5\Omega$**
-  **The flowmeter is equipped with a grounding electrode (third electrode). In the case of plastic or coated pipes, we recommended the use of ground rings.**

Earthing rings can be used on both ends of the pipes. The earthing rings are indispensable in the case of plastic or coated metal pipes to ensure good potential compensation. Earthing rings are supplied on request. Refer to the images on the following pages for more information.

4.6.3.1 Plastic Pipe Installation using Grounding Rings

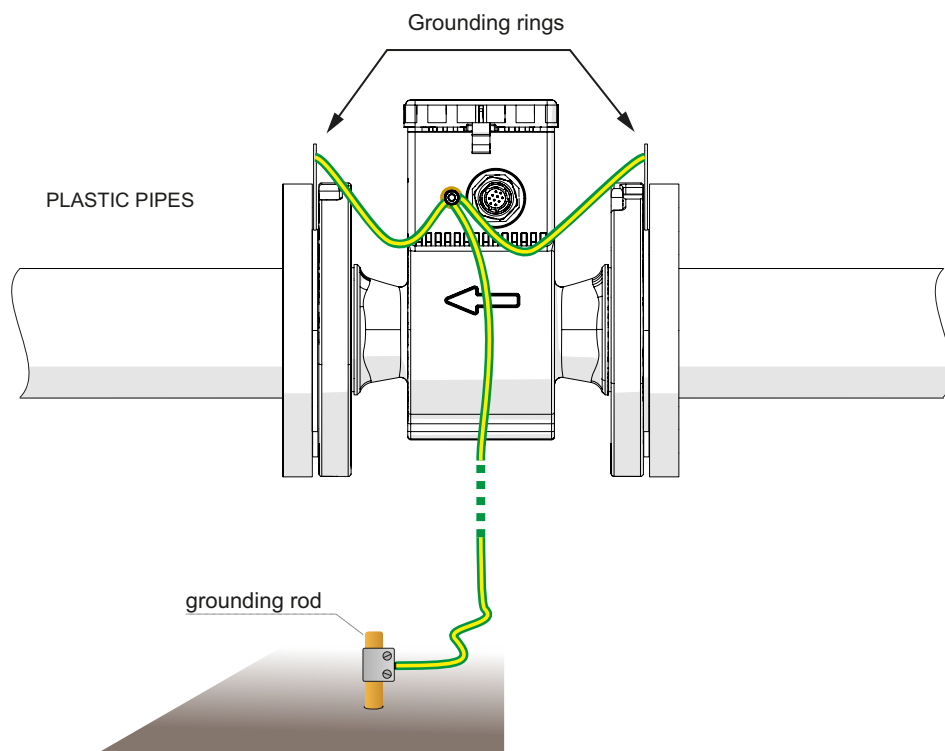

Fig. 41

4.6.3.2 Metal Pipe Installation

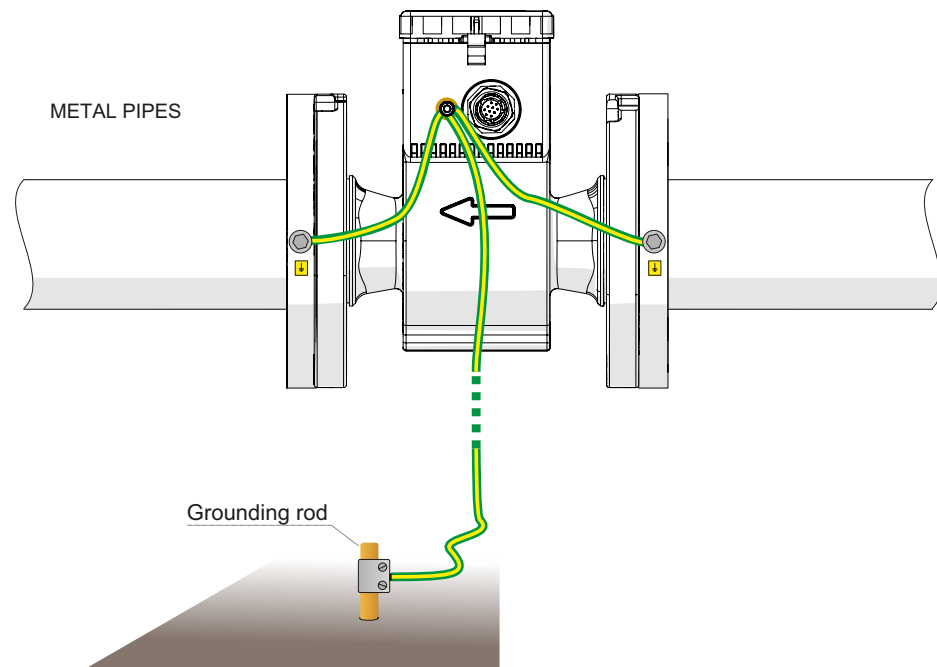

Fig. 42



For a correct device operation, it is necessary to carry out a connection in a well-executed manner.

4.6.4 Connection to the power supply



THE ELECTRICAL CONNECTION OF THE DEVICE MUST BE CARRIED OUT BY QUALIFIED TRAINED PERSONNEL.

Make sure that all electrical connections have been made correctly before connecting the unit to the power supply.

Power supply: 12VDC - 100mA (10.8 ÷ 13.2 V)

Power consumption: 0.25 ÷ 1 W

4.7 BATTERY INSTALLATION

Follow the instructions below to install the battery:

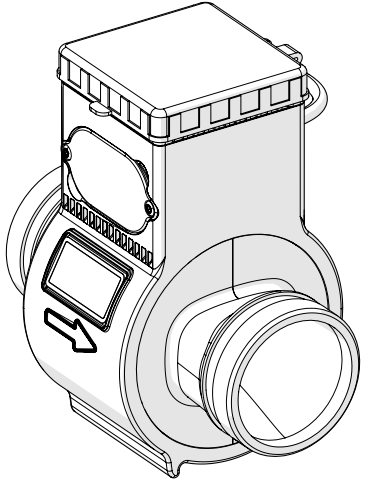
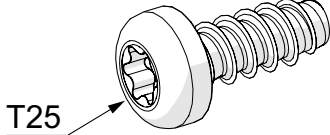
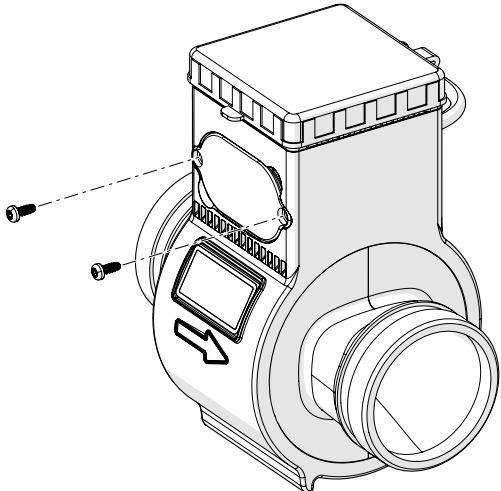
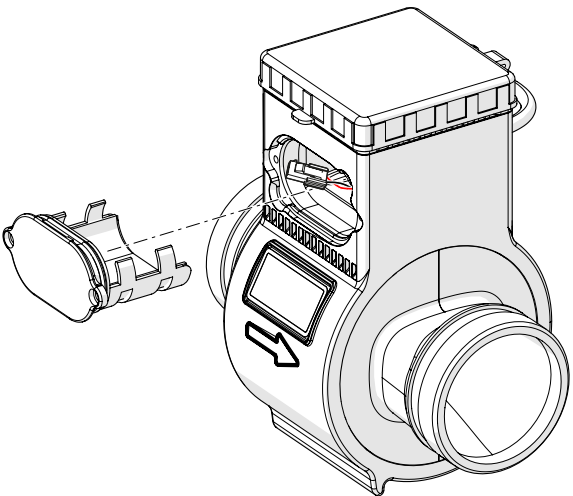
<p>0- Initial configuration</p>	
<p>1- Remove the 2 hex-lobular (T25) drive screws</p> 	
<p>2- Remove the battery compartment (If needed help yourself with a flat screwdriver to remove the cap)</p>	

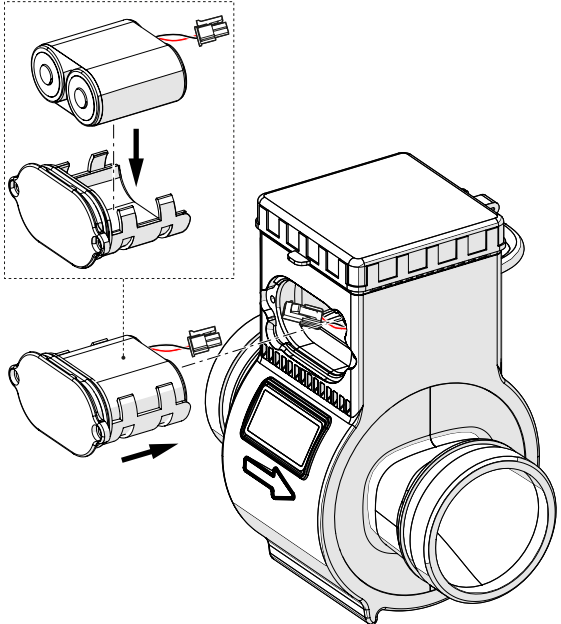
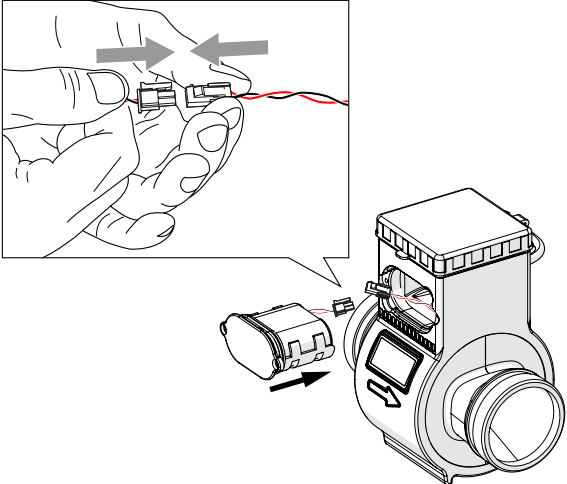
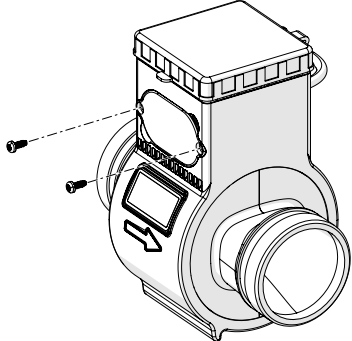
<p>3- Place the battery pack in its housing</p>	
<p>4- Connect the battery wire</p>	
<p>5- Close the battery compartment and tighten the screws (2.5Nm max)</p>	
<p>6- Once the battery has been replaced swipe the magnet to say YES (for more information see chapter 5.2 FIRST ACTIVATION)</p>	<div data-bbox="1075 1787 1353 2069" style="border: 1px solid black; padding: 10px;"> <p style="text-align: center;">rEPLbAtt nO YES</p> <p style="text-align: center;"><i>Replace battery:</i> -NO: do nothing -YES: swipe the magnet</p> </div>

5 METER PROGRAMMING

5.1 DISPLAY

MUT7000 is equipped with a two rows segment display and a magnetic switch (reed) on the right side of the display.

The LCD can visualize an 8 and a 6 digits numbers plus several information icons, allowing the user to display several information and set many parameters. On details, it is possible to show:

- Instantaneous flowrate
- Positive totalizer (T+)
- Negative totalizer (T-)
- Partial positive totalizer (P+)
- Partial negative totalizer (P-)
- Net totalizer (N)
- Time & date
- Parameters corresponding code and value

	Battery charge icon: See page 45		T: Totalizer P : Partial totalizers N : Net totalizer
	8 digits number		Generic error icon
	6 digits number		Sensor failure icon
	Volume technical unit		Empty pipe icon
	Flow rate technical unit		Sleep/awake icon: On→ awake Off→ sleep mode
	Bluetooth icon: 1s flashing→ Initializing Fixed → Ready configured 2s flashing → Connected		DC mains icon: On→ meter powered by DC mains
	RS485 icon: Flashing→ Communicating Fixed→Waiting for communication		

By swiping the magnet, it is possible to switch display views and execute some basic operations.

Four views are available:

- Measurement views (“5.3 USER INTERFACE”)
- Converter’s settings (“5.5 FUNCTIONS”)
- Firmware’s updating view (“5.9 FIRMWARE UPDATE”)
- Meter reset (“5.10.1 Reboot”)

5.2 FIRST ACTIVATION

After the physical installation of the instrument has been completed, the electronic converter can be powered on by plugging in the battery pack to the connector or by connect it to the DC mains.

Depending on the instrument configuration, the MUT7000 can be shipped with the battery pack disconnected or already inside the meter and connected.

If disconnected: the unit is automatically operative once connected to mains power or when the battery pack is installed (see 4.6.4 / 4.7).

If already connected: the unit is suspended and needs to be activated. To activate a suspended unit, it is necessary to swipe the magnet.

A sequence of 7 views will be displayed:

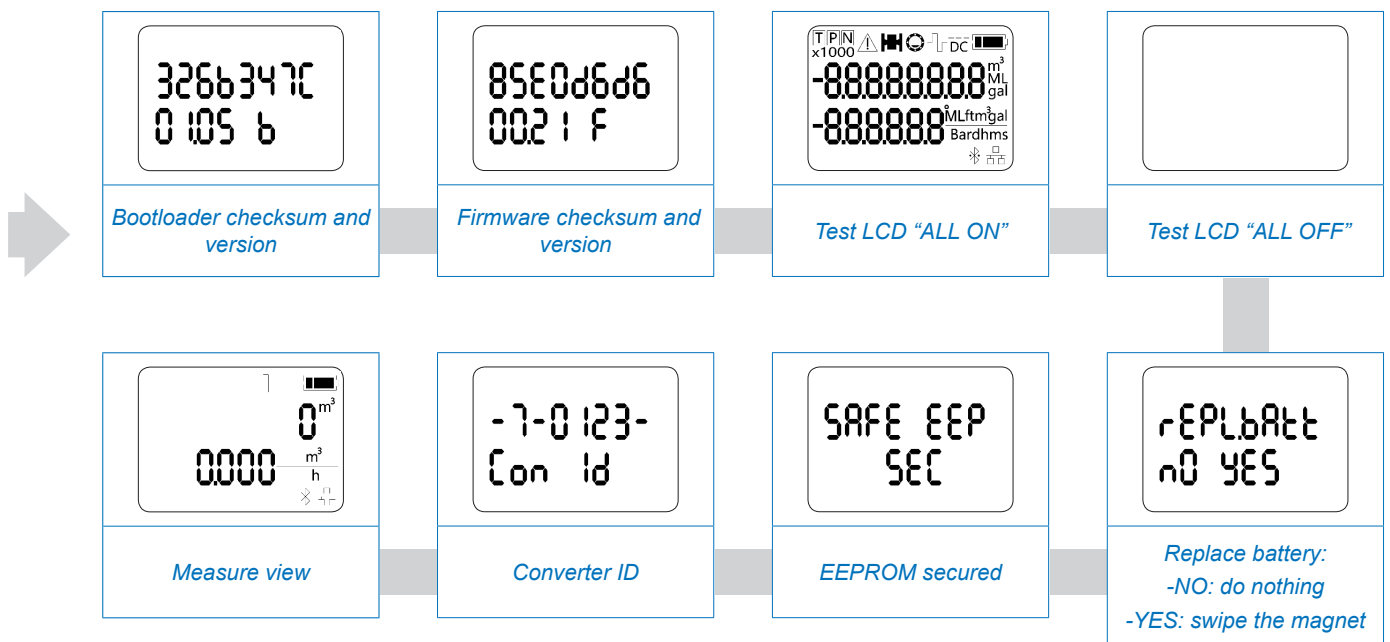

5.3 USER INTERFACE

Measurement views displays totalizer and flow rate.

To change the view, bring the magnet closer to the reed for 1 second and then move it away.

Thirteen configurations are available:

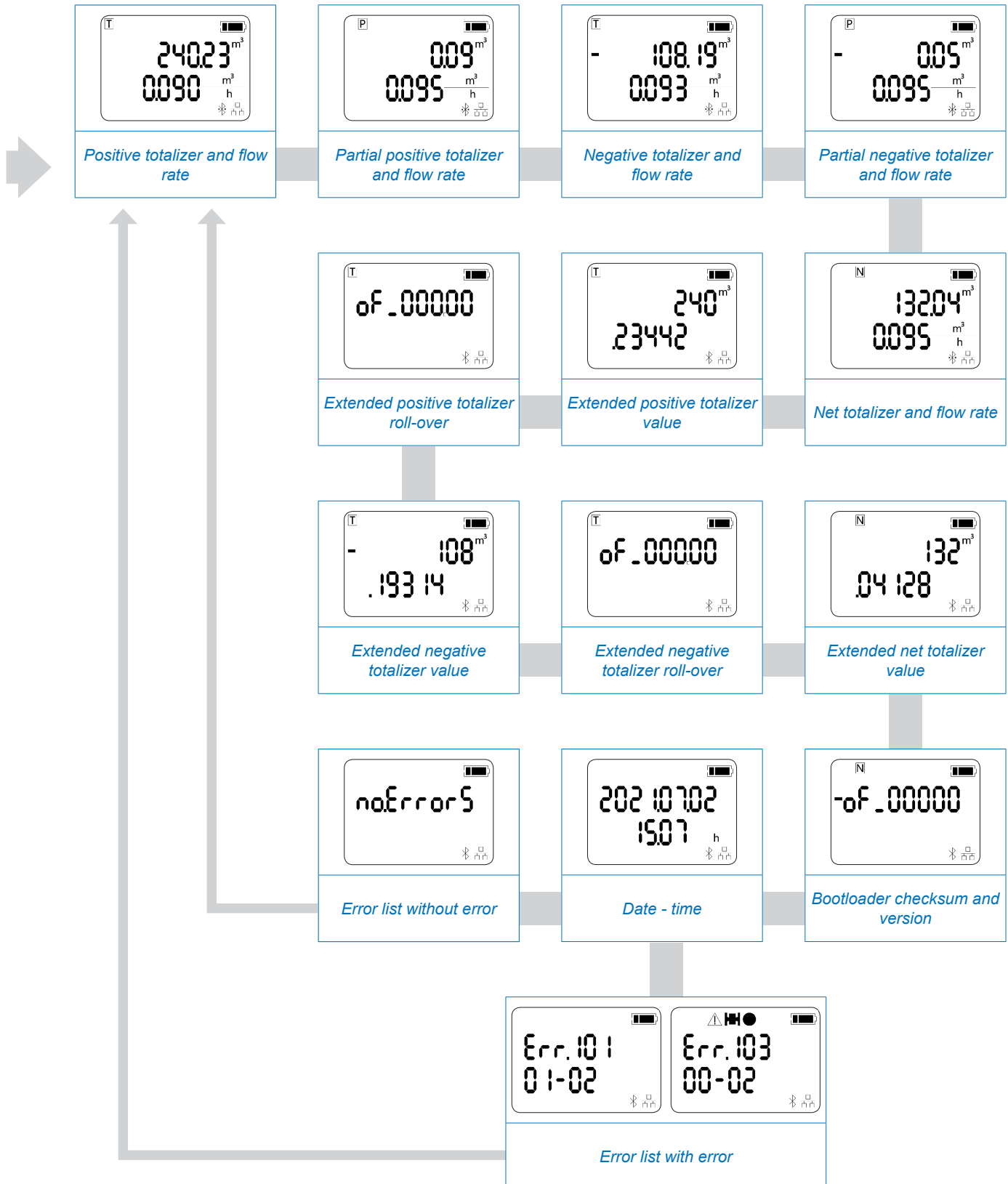

5.4 DISPLAY TEST

The LCD display integrity can be checked by the converter settings menu (functions, see chapter 5.5), by resetting the device (see chapter 5.10) or at the first activation (see chapter 5.2); all the display segments will be activated and cleared in sequence. Also, the firmware version / revision (vv.rr) and its checksum are displayed. When completed, the previous measurement screen will be restored.

5.5 FUNCTIONS

This view displays the converter's settings.

To activate this view, bring the magnet closer to the reed until it appears (5 seconds) and then move it away.

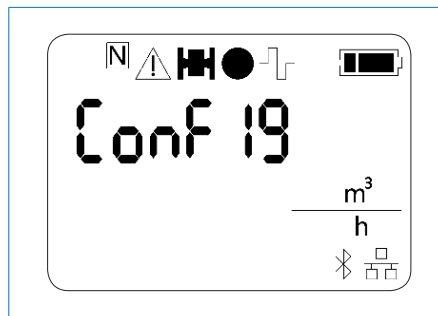

A sequence of 16 views will be displayed (view's duration is 5 sec), to interrupt the scrolling and come back to measure view, bring the magnet closer to the reed for 5 second and then move it away.

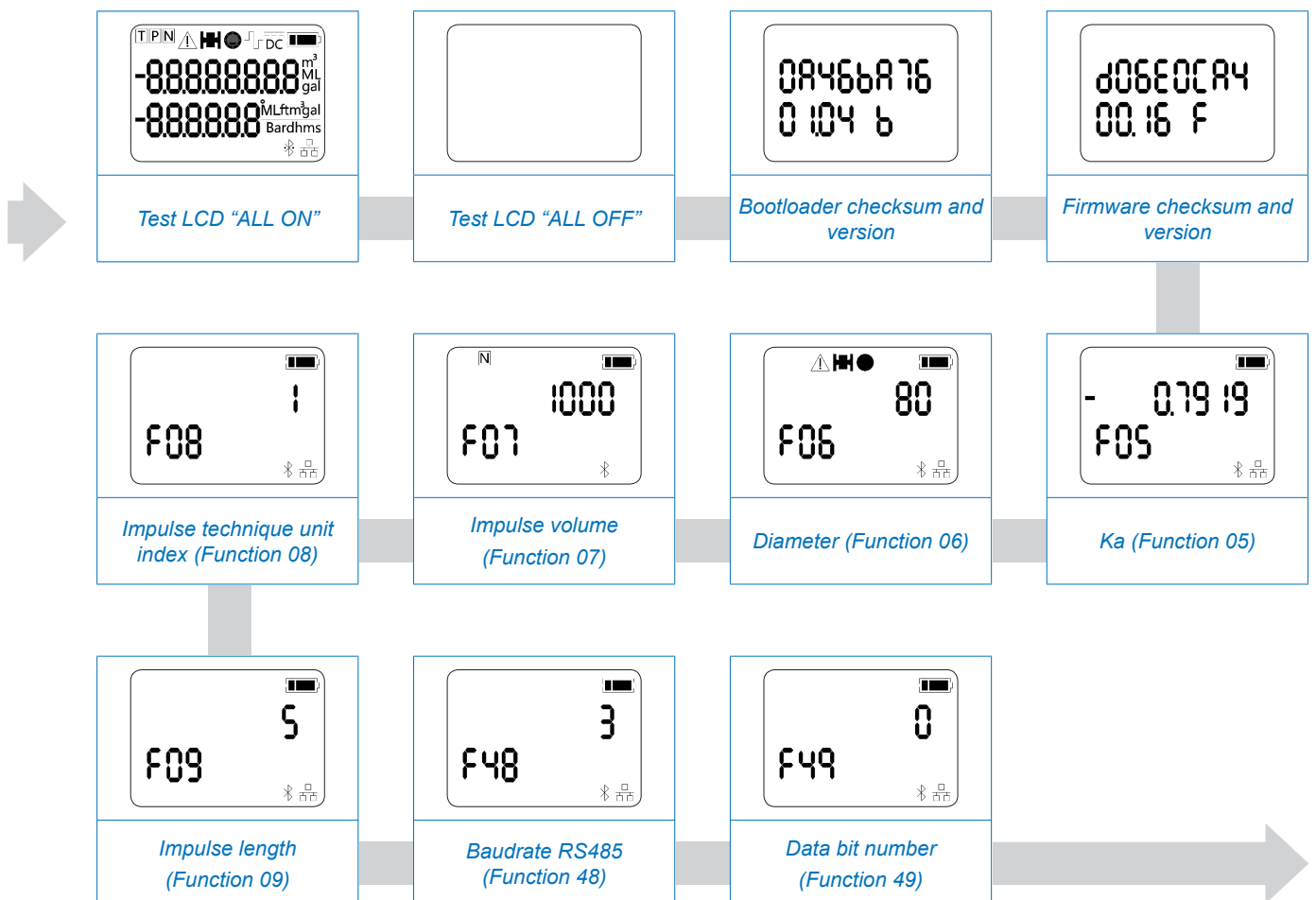

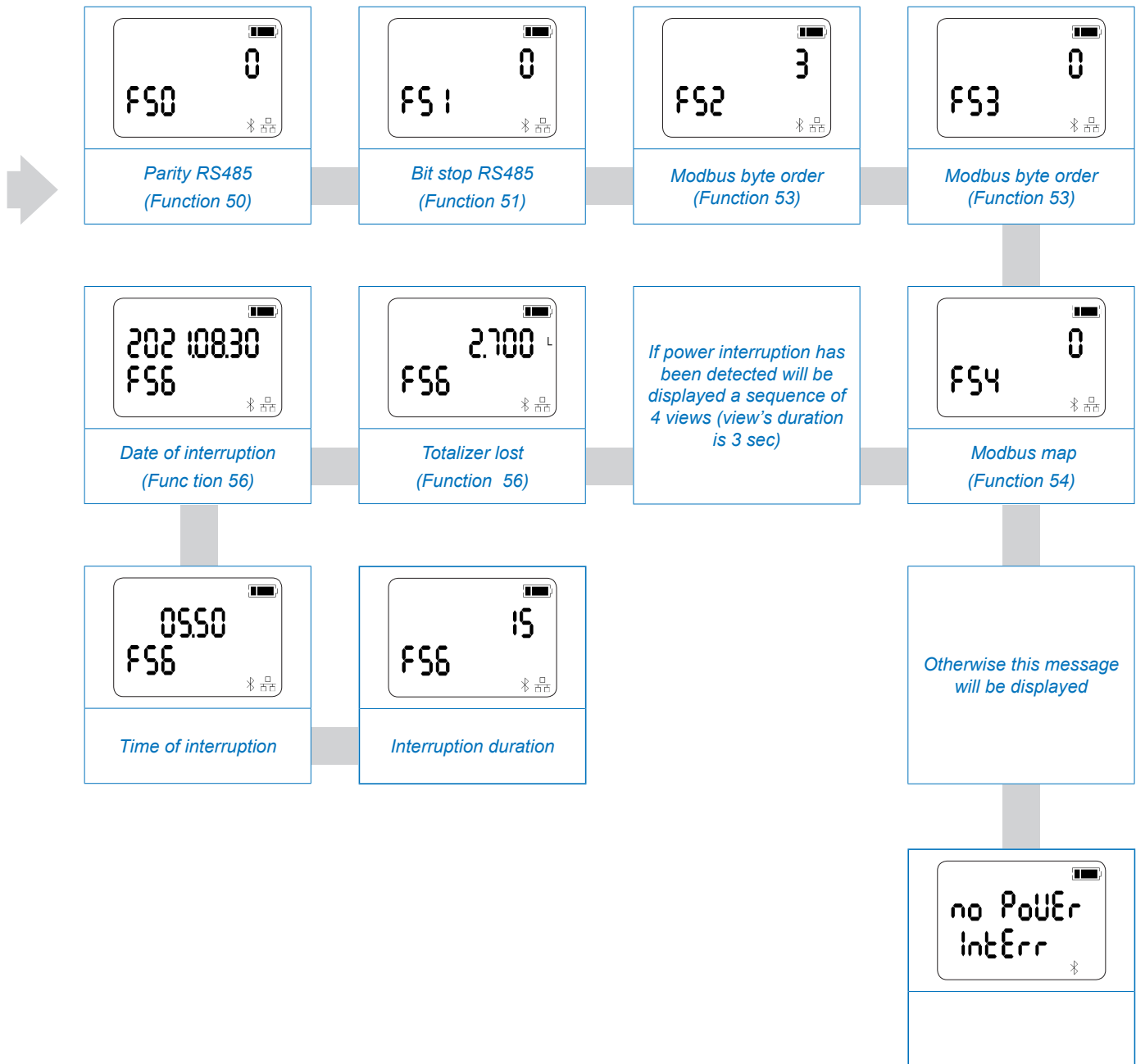

To come back to measure view, bring the magnet closer to the reed for 5 second and then move it away.

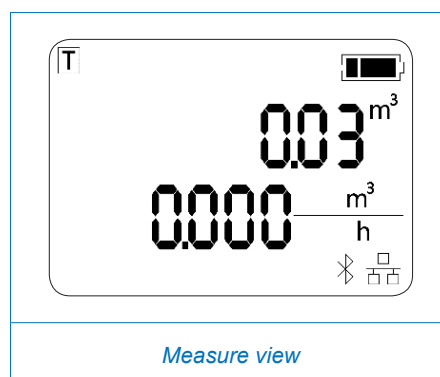

A list of all the accessible functions from the user interface follows

5.5.1 List of functions available through display interface



FUNC.	DESCRIPTION	MIN VALUE	MAX VALUE	NOTES	ACCESS
5	Ka factor	-10.0	10.0	Calibration Factor	MID Read only STD: Advanced
6	Sensor diameter	1	4000	Meter Nominal size in [mm]	MID Read only STD: Advanced
7	Pulse volume	1	10000	Volume of pulses in the Pulse technical unit	Device password
8	Pulse technical unit	1	4	1=mL; 2=L; 3=m3; 4=gal	Device password
9	Pulse duration	5	500	Expressed in ms (seconds/1000)	Device password
48	Modbus Baudrate	0	5	Modbus Baudrate 0: 2400 1: 4800 2: 9600 3: 19200 4: 38400 5: 57600	Device password
49	Number of Modbus bit	0	1	Number of modbus bit 0: 8 bit data 1: 7 bit data	Device password
50	Modbus parity	0	2	Modbus parity 0: None 1: Odd 2: Even	Device password
51	Modbus Stop bit	0	1	Modbus Stop bit 1 bit stop 1: 2 bit stop	Device password
52	Modbus address	1	255	Modbus address	Device password
53	Modbus Byte-order	0	3	Modbus Byte-order 0: little endian 1: big endian 2: little endian byte swap 3: big endian byte swap	Device password
54	Modbus Map	0	1	Modbus map 0: Euromag 1: Sofrel	Device password

FUNC.	DESCRIPTION	MIN VALUE	MAX VALUE	NOTES	ACCESS
56	Power interruption info (last event)			Shows in a three second sequence the information about the last power interruption 1) Last accumulation (estimation based on the last flow rate reading) 2) interruption date 3) interruption hours 4) interruption duration in seconds	Read Only
57	Power interruption info (total events)			Shows in a three second sequence the information about the last power interruption 1) Last total accumulation (estimation based on the last flow rate reading) 2) interruption date of the first event 3) interruption hours of the first event 4) interruption total duration in seconds 5) Number of interruption events	Read Only

5.6 BATTERY

The MUT7000 meter can be powered with a lithium battery pack, offering over 10 years of service (depending on the configuration and the working conditions). The residual life is estimated by calculating the energy usage over the instrument's life, so when the battery pack is replaced, it is necessary to reset the battery usage counter. Powering up the unit automatically takes the user to a selection screen (see "5.2 FIRST ACTIVATION").

NOTE: waking-up the unit frequently or entering very long power down timeouts can reduce the expected battery life.

	battery good
	25% or less
	10% or less

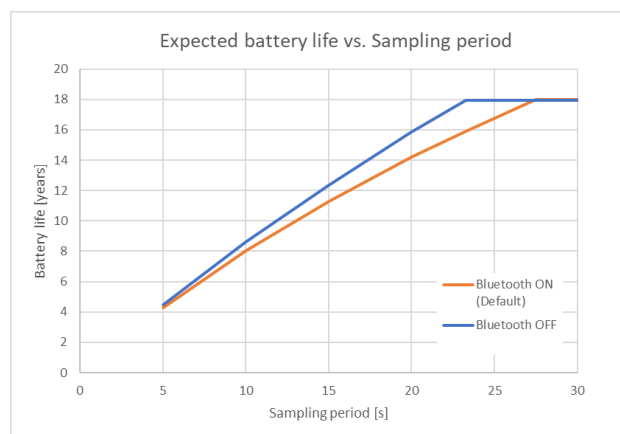

Fig. 43 Expected battery life (years) VS sampling period

5.7 ACCESS VIA MAG-NET APP

The meter can be operated and configured via the Mag-Net mobile app, the connection is performed via Bluetooth communication channel.

Mag-Net functions:

- List available devices and connection list
- Instantaneous measures and datalogger access device
- Device configuration and access diagnostic information
- Firmware update

Mag-Net is available for free for Android and iOS devices



System requirements:

- iOS: iOS or iPadOS 10.0 or higher
- Android: 8 or higher

Install and start the Mag-Net app

- A list of all available devices is shown, by default devices are identified through device S/N: Y7K00000
- Select the device you want to connect
- Enter the device password, default password is 000000
 - » The first time you connect a message advising the change of the password is displayed, it is strongly recommended to change the default password the first time you connect, Mag-Net can save the device password so you do not need to remember it, you can also share the password with others through the app itself.
- Once connected you will see the meter dashboard with instantaneous live measurement and main information about the device. You can navigate through following sections:
 - » Instantaneous flow rate measure
 - » Meter log
 - » Configuration

5.8 ACCESS VIA EUROMAG-LINK

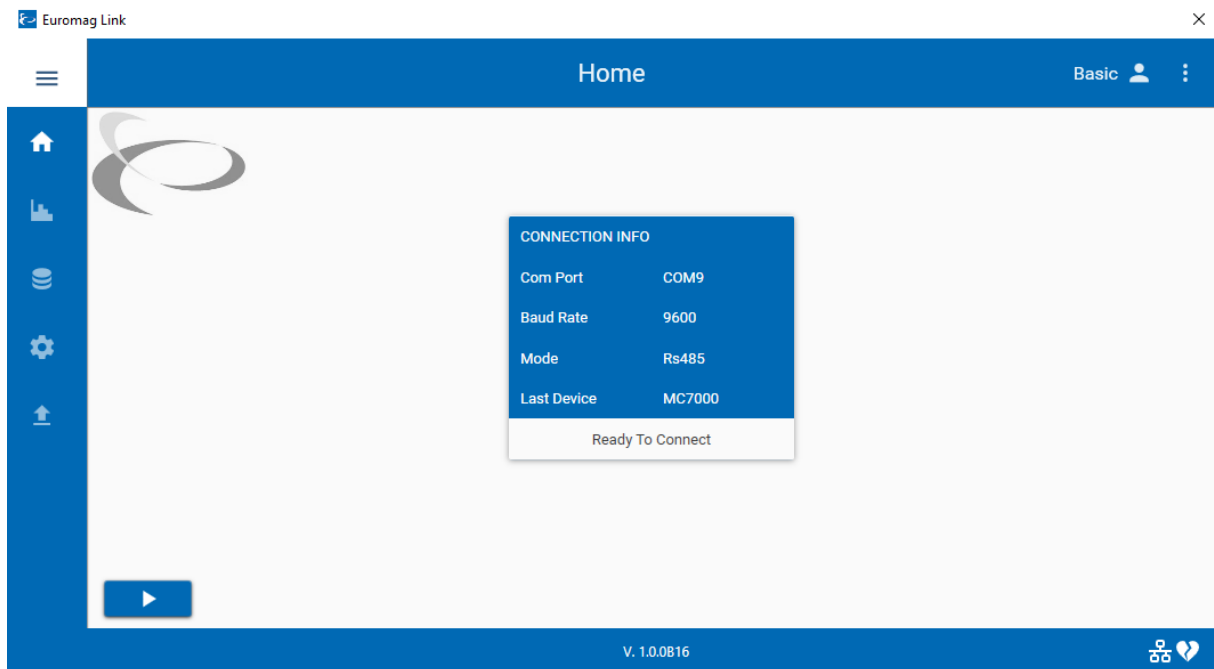

5.8.1 Access via RS485

Connect the meter with RS485 to USB cable or other USB connection device

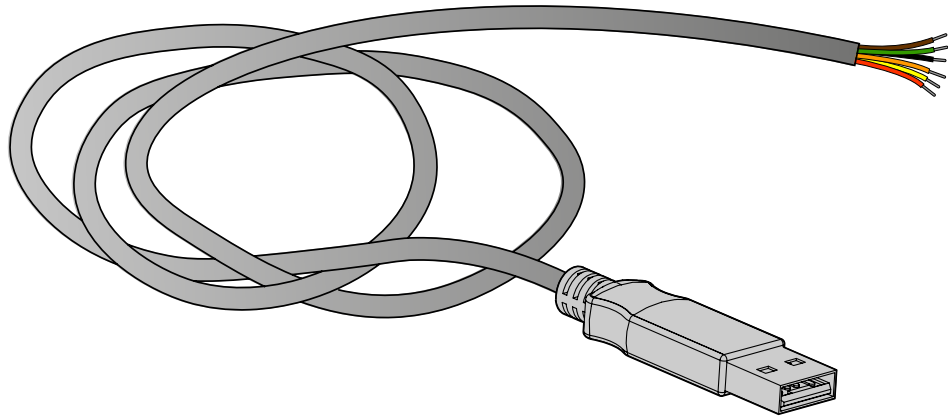





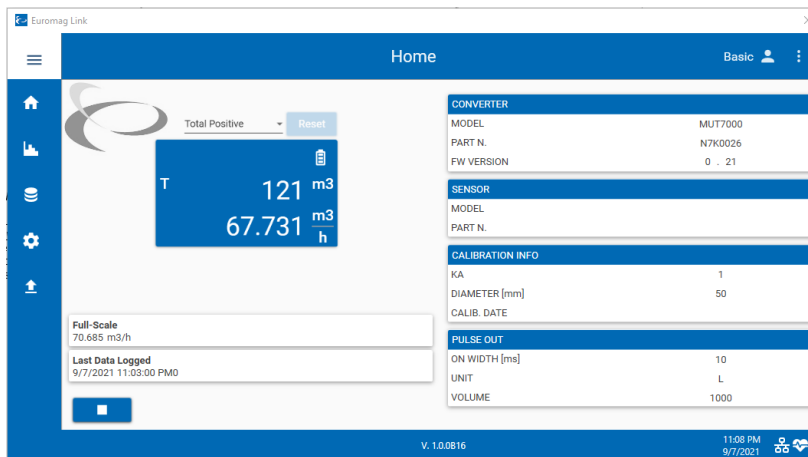
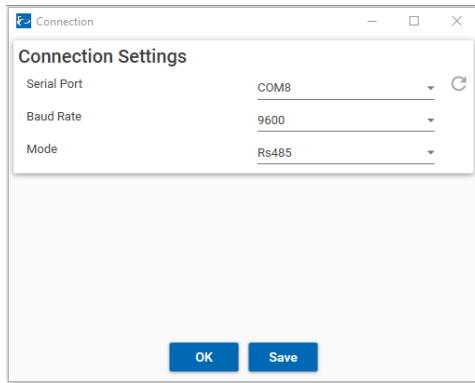

Fig. 44 RS485 cable (Part N° "CABLE001")

- Click the menu button  on the top right of the screen
- Select  Settings
- Select  Connection
- On the Connection Window, select Mode -> Rs485, correct Serial Port and the Baud Rate (for MUT7000 default Baud Rate is 9600)
- Click  Save button
- Close the Connection and the Settings Windows
- On the Home screen press  to start connection



5.8.2 Access via Bluetooth

Connect Euromag-link via Bluetooth using the dongle connected to a PC.

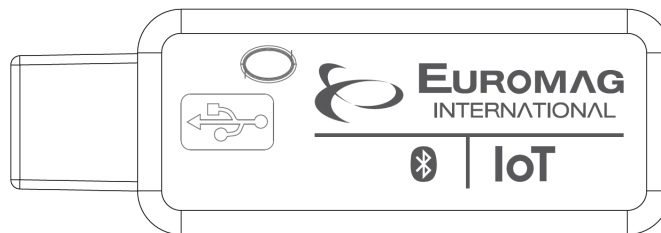





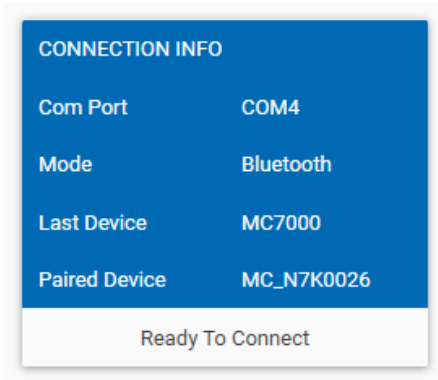
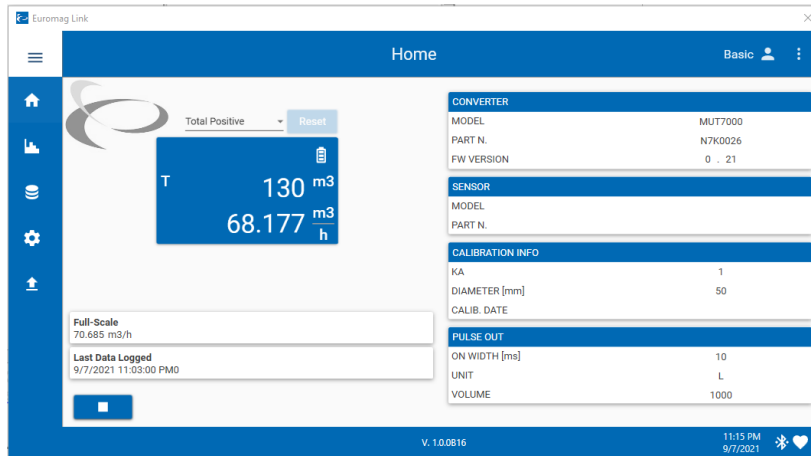
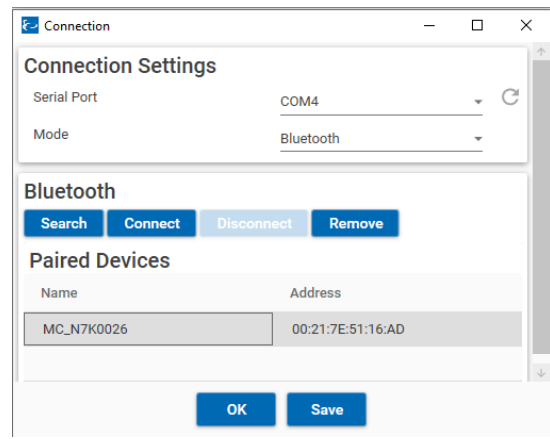
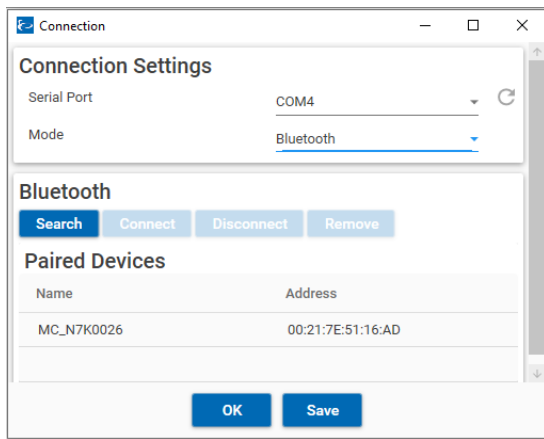

Fig. 45 Bluetooth Dongle (Part N° "DNG001")

- Click the menu button  on the top right of the screen
- Select  Settings
- Select  Connection
- On the Connection Window, select Mode -> Bluetooth
- If desired Device is on the Paired Devices list, select and click 
- Click on  to discover available devices, then select the device in the shown list to connect.
- Close the Connection and the Settings Windows
- Last connected device, will be available for fast connection on the Home screen



- On the Home screen press  to start connection to the last connected devices.



5.9 FIRMWARE UPDATE

To update the converter with a more recent firmware release select the firmware .hex file and click on download new firmware to converter. The firmware download progress is shown while the instrument will display the internal operations sequence. The actual working firmware is backed up on a dedicated memory area, so in case of failure the converter will automatically recover the normal functionality.

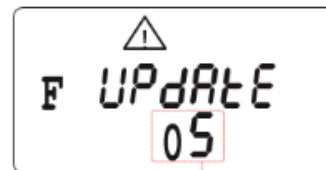
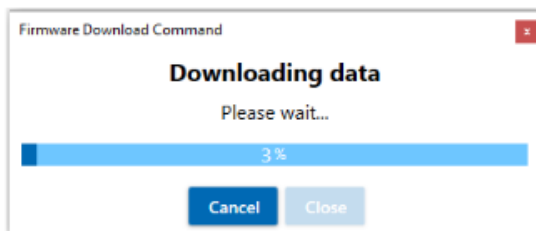
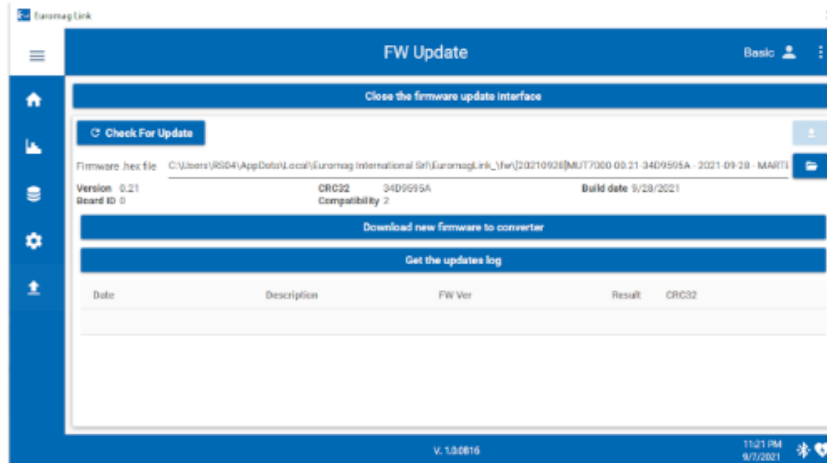

update process step

0	Working firmware check	6	Working firmware backup
1	Waiting for the download request	7	Working firmware update
2	Download request received	8	New working firmware backup
3	Erasing download memory	9	Update OK
4	Firmware downloading	10	Restore working firmware (during start-up only)
5	Checking the downloaded firmware	11	Restore working firmware (after update failure)

Every firmware download attempt is logged in the internal memory. Selecting “get updates log” after the reset will show the download attempt log. The log can store over 500 records: once full no more downloads are allowed.

Date	Time	ID	Step	Success	Fw Rev.	crc32
01/01/2015	14:27	0	Update Ok	True	01.00	000FB47E
01/01/2015	14:29	0	Downloaded Fw ...	False	01.00	FFFFFFFF
01/01/2015	14:30	0	Update Ok	True	01.00	000FB47E

The download attempt log can also be visualized on the converter display: to activate this view, bring the magnet closer to the reed until it appears (10 second) and then move it away.

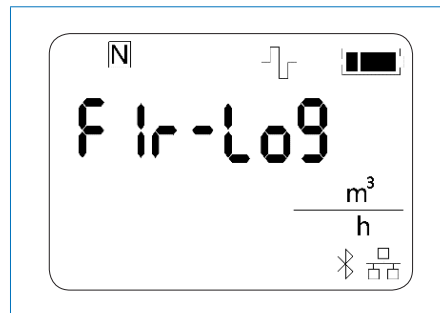

A sequence of 4 information's views will be displayed (view's duration is 5 sec):

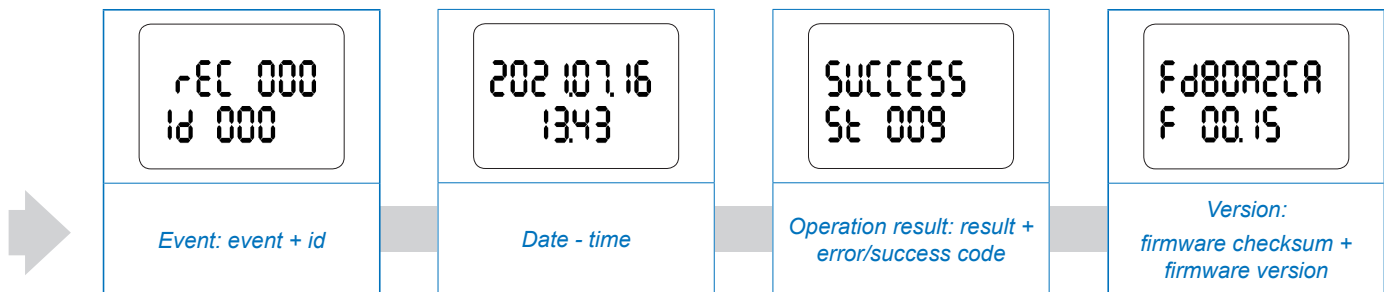

To move to next attempt, bring the magnet close to the reed for 1 second and then move it away.

To come back to measure view, bring the magnet close to the reed for 5 second and then move it away.

5.10 DEVICE RESET

5.10.1 Reboot

In order to reboot the device, bring the magnet closer to the reed until the “reset” string appears (15 seconds needed). Then device will reboot.

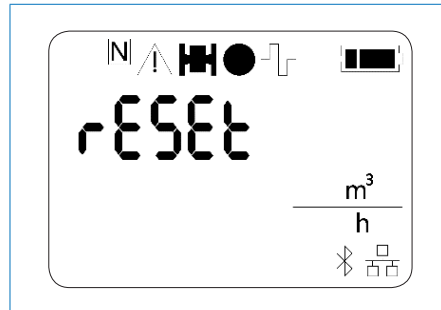

To reset the meter to the factory configuration the advance mode is required; click on Load Factory Data button.

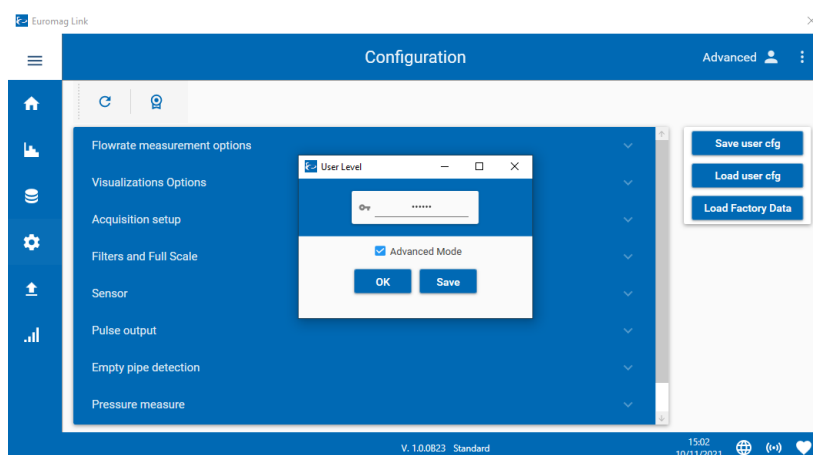
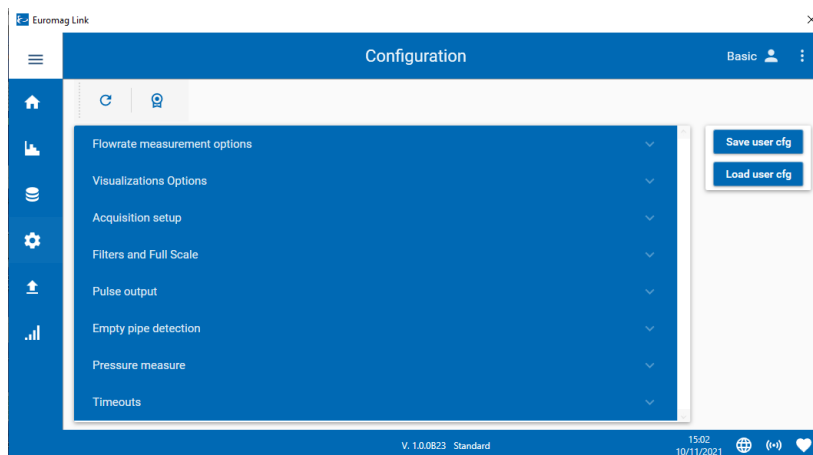

5.11 METERS SUBJECT TO LEGAL METROLOGY

5.11.1 Metrological seals

MID Certified instrument are equipped with a set of metrological seals under the display labels, these seals must not be removed, otherwise the metrological guarantee of the instrument will be lost

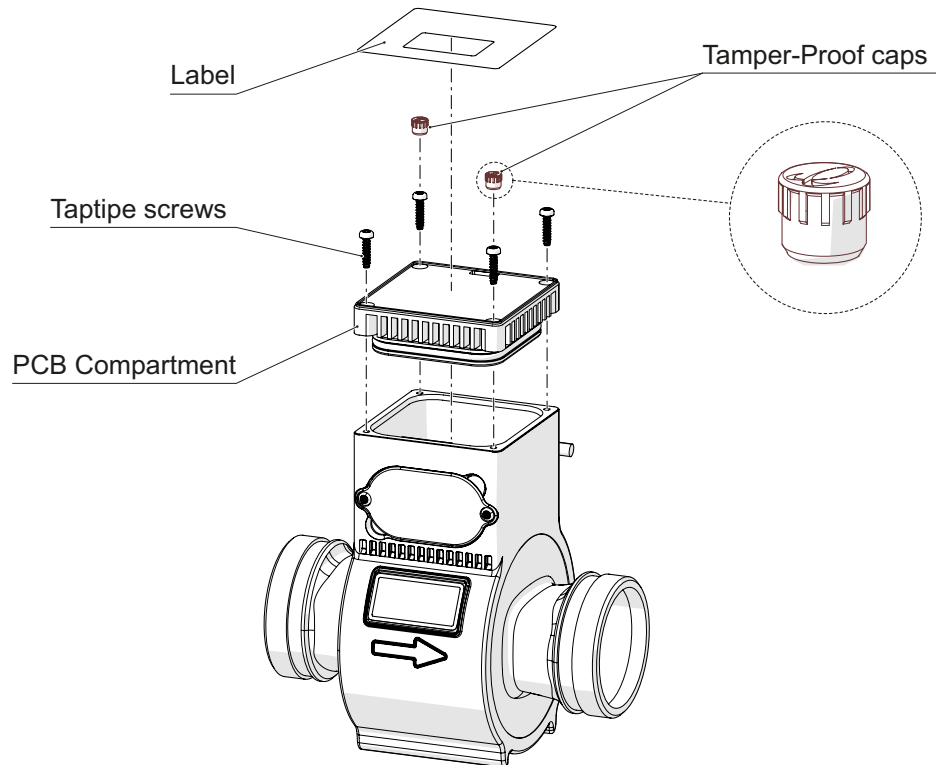

Fig. 46 Metrological seals

5.11.2 Utility seals

For in field utility sealing, it is available a special bracket in order to avoid battery removal

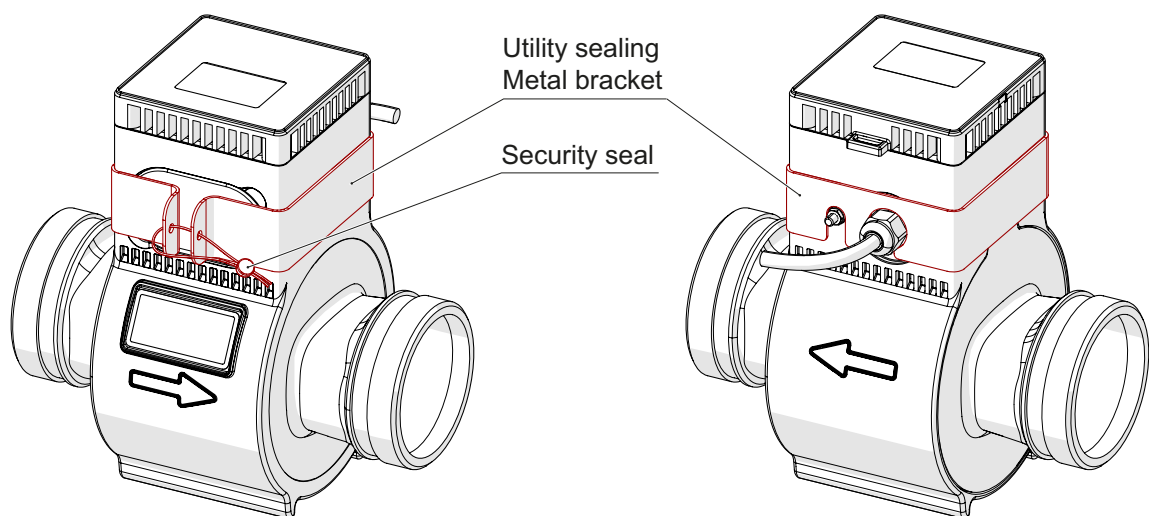





Fig. 47 Utility seal

6 MAINTENANCE

-  The meter is not equipped with moving parts and/or mechanical parts subject to wear and therefore it does not require any ordinary maintenance except for the periodic check of the correct closure of the cable glands, the condition of the sealing gaskets of the covers and the replacement of the discharged battery.
-  The device (front panel and converter casing) can easily be cleaned with soft cloths and neutral detergents.

6.1 CABLE GLAND CLOSING AND GASKET CONDITION CHECK





Since the environmental characteristics where the meter is installed are not known in advance, it is not possible to provide univocal indications on how often periodic checks on cable glands and gaskets should be performed.

-  The operating experience of the user and the knowledge of the environmental characteristics of the flowmeter installation location will allow the operator to decide how frequently regular controls must be made.
-  **Warning!** Flowmeters that are positioned outdoors and/or in places/supports subject to vibrations can loosen the cable glands over time, so they must be checked/controlled more frequently than flowmeters that are installed in closed environments and/or protected from external stresses.

CHECKS

- » Perform periodical checks of the tightness of the cable glands and their condition.
- » On this occasion, check the condition of the seal in the cover.
- » Finally, check that all the electrical cables are correctly affixed to the relative terminals, that they are physically intact and that they do not show signs of deterioration.

6.2 BATTERY INSTALLATION/REPLACEMENT

-  The battery pack is usually **SEPARATELY** supplied, therefore, before the MUT7000 is put into operation, the battery pack must be inserted in its housing and connected to the instrument according to the instructions provided in chapter 4.7.
-  **NOTE:** The operations described in chapter 4.7 are also valid for the replacement of the battery, which is necessary to be performed when the status icon “” indicates a low charge level on the MUT7000 display.
-  **NOTE:** Under normal operating conditions, the battery life can last up to 10-15 years. Any changes to the settings and programming of the converter (see paragraph 5.3) can affect the battery life.

7 TROUBLESHOOTING

7.1 MALFUNCTIONING AND POSSIBLE SOLUTIONS



The following table summarizes the possible malfunctions that may occur during the use of the MUT7000 meter, for which the possible causes and solutions to be adopted in order to restore correct operation of the flowmeter are listed.

MALFUNCTIONING	POSSIBLE CAUSE	SOLUTION
The meter shows a flow rate even when there is no flow.	Grounding missing or incorrect.	Check that the meter and the liquid are correctly grounded, making sure that the relative earth ground connections are correctly connected.
	Lack of liquid in the sensor downstream of the converter.	Check that the sensor is full of liquid.
	Electric conductivity of the liquid is too low, or it is not compatible with the material used for the sensor electrodes.	Check which electrode type is used on the sensor. If necessary, replace electrodes and/or sensor.
	Missing or incorrect "zero calibration".	Perform manual zero calibration if necessary.
	Cut-off filter value is too low for the process.	Increase filter value.
External pulse totalizer shows results different than expected.	Pulse output configuration error.	Check the pulse volume and pulse duration settings. Simulate a flow rate through System > Simulation and test the output using a pulse counter.
The screen is turned off and it doesn't turn on.	There is no voltage supply, or it is incorrect.	Mains powered: Check the power supply is 12Vdc
		Battery powered: check the battery life and correct installation, replace the battery pack.
The flow reading is very unstable.	Hydraulic nature: Air bubbles/pockets or unstable flow (vortex motion). The minimum required linear distances upstream and downstream of the device were not complied with.	Check for the minimum required linear distances upstream and downstream of the device. Check for the presence and correct installation of vents on the pipe to avoid the presence of air in the pipe.
	Electrical nature: Grounding missing or improperly made, oxidized nodes, very noisy ground point, usually in common with the grounding systems of pumps or inverters, liquid conductivity is too low.	Change the grounding point or preferably create a new one for the exclusive use of the meter.
	NOTE: If with full pipe and stable liquid an unstable reading can be observed (which varies rapidly) then most likely it is a problem of electrical noise. Only if necessary, set the filters in the following way: <ul style="list-style-type: none"> • Set the "damping" to 150 • Reduce the "peak cut off" filter • Increase the "bypass" filter 	





7.2 SELF DIAGNOSTIC



In this paragraph you will find the alarm messages that can be shown on the display when the relative status icon appears. Each alarm message is accompanied by possible causes that generated it and the possible solutions to be applied in order to restore the correct functioning of the flow meter.

During the measuring process MUT7000 detects automatically if a fault condition occurs and eventually stops the measurement reporting an alarm indication on the display. The following table describes the various alarm conditions and the behaviour of the converter.

DETECTED ANOMALY	POSSIBLE CAUSES	CONVERTER BEHAVIOUR	DISPLAYED ICONS & CORRESPONDING ERROR CODE	POSSIBLE SOLUTIONS
Excitation failure	<ul style="list-style-type: none"> » Damaged meter; 	The measure is forced to 0 and the error condition is displayed and logged	 101	Contact service center
Empty pipe detected / Invalid measure on the measuring electrodes	<ul style="list-style-type: none"> » The sensor is at least half empty » Air is injected and causes turbulence; air bubbles/pockets » Liquid conductivity is too low » An electric dispersion on the process is affecting the measure » A high source of electromagnetic interference is affecting the measurement » Incorrect grounding, on plastic pipe: grounding rings are missing, incorrect or damaged electrical connection to the sensor/ converter 	The measure is forced to 0 and the error condition is displayed and logged; to save battery energy the coil excitation is stopped until the error condition goes off	 103	<p>Check if the sensor has been correctly installed and if there is air inside the pipe.</p> <p>Make sure that the sensor and converter are properly grounded.</p> <p>Check the absence of high electromagnetic noise sources, caused by inverters or other power equipment</p>
Temperature exceeds the nominal converter working range	<ul style="list-style-type: none"> » The environment temperature is over the working range; » The converter exposed to direct sunlight 	The error condition is displayed	 201	Ensure adequate protection from sunlight
Wet electronic board	<ul style="list-style-type: none"> » Water intake or a humidity condensation inside the converter case, » Battery compartment not properly closed. 	The error condition is displayed	 202	Contact service center
Supply voltage out of range	<ul style="list-style-type: none"> » The battery pack is damaged or empty » A wrong power source is connected to the converter 	The error condition is displayed	 301	Replace the battery pack or connect the correct power source
Pulses overlapping	<ul style="list-style-type: none"> » The pulse settings are not compatible with the measured flowrate 	The error condition is displayed	 401	Change the settings of the pulse volume and duration (see "4.6.2.1 Pulse output" on page 30).

DETECTED ANOMALY	POSSIBLE CAUSES	CONVERTER BEHAVIOUR	DISPLAYED ICONS & CORRESPONDING ERROR CODE	POSSIBLE SOLUTIONS
Bluetooth Error	» Not working Bluetooth communication	The error condition is displayed	 601	Power reset the instrument, by disconnecting all power sources. If the problem persist contact service center
Main Power interruption	» Main power interruption detected » Supply voltage out of operating range	The error condition is displayed	 701	Check the power supply network
Firmware checksum differs from the attended value	» The internal program memory has changed	The error condition is displayed and the program execution stopped	 801	Try to update the firmware
Parameters' checksum differs from the expected value	» The parameters data are corrupted	The error condition is displayed and the program execution stopped	 802	Restore factory settings
A watchdog reset was performed	» A disturbance caused an unhandled behaviour in the regular software execution	The instrument was reset to restore the functionality; the alarm is cleared after it has been displayed	 901	If the problem persists contact service centre

8 SENDING THE CONVERTER TO THE MANUFACTURER

The device was manufactured with extreme care and passed rigorous tests before shipment from the factory. If the installation and maintenance are carried out correctly, it is very unlikely that malfunction will occur.

However, if it should be necessary to send the device to our customer service for any checks or repairs, please pay attention to the following points:

- According to the legal provisions on environmental protection and in order to preserve the health and safety of our personnel, the manufacturer can only test and repair sent back devices that have been in contact with products that are risk-free for the personnel and the environment.
- This means that the manufacturer can perform the service on the device only if the latter is accompanied by the “Return Merchandise Authorization” stating that the device itself can be safely handled.

8.1 RETURN MERCHANDISE AUTHORIZATION



The “Return Merchandise Authorization” form shown on the following page must be photocopied, filled in and attached to the device that needs to be checked/repared by our customer service.

	Modulo richiesta riparazione/ Return <i>Merchandise Authorization (RMA)</i>	 <small>COMPANY WITH QUALITY SYSTEM CERTIFIED BY DNV GL = ISO 9001 =</small>
---	---	--

Nome Azienda/ <i>Company Name</i>	
---	--

Indirizzo Azienda/ <i>Company Address</i>	
---	--

Tel.		Fax	
-------------	--	------------	--

Tipo di sensore/ <i>Sensor type</i>		N. di serie/ <i>Serial n.</i>	
---	--	---	--

Tipo di convertitore/ <i>Converter type</i>		N. di serie/ <i>Serial n.</i>	
---	--	---	--

Liquido trattato/ <i>Treated liquid</i>		Pulizia interna sensore/ <i>Sensor internal cleaning</i>	YES <input type="checkbox"/>
---	--	--	-------------------------------------

Reclamo/ <i>Claim</i>	

Data restit. richiesta/ <i>Required return date</i>		Data restit. confermata/ <i>Confirmed return date</i>	
---	--	---	--

Con la presente si conferma che non vi è alcun rischio per le persone o per l'ambiente in conseguenza di sostanze residue contenute nel dispositivo che viene restituito.
We hereby confirm that there is no risk to persons or the environment due to any residual substances contained in the device that is returned.

Data/ <i>date</i>	
-----------------------------	--

Timbro azienda/ <i>Company stamp</i>		Firma/ <i>Signature</i>	
--	--	-----------------------------------	--

9 PRODUCT DISPOSAL

If you decide to put the converter out of service because it is definitely no longer in use, disconnect it from the electrical power source and from the cables connected to the sensor before proceeding to its removal and its disposal.

Disposal of the device is the responsibility of the user who must comply with the specific laws regarding environmental protection of the country of installation.

MANUFACTURER'S STATEMENT

The manufacturer declares that the design, development and construction of the flowmeter have been carried out in compliance with the Directive on the reduction of the use of dangerous substances with particular attention to waste electrical and electronic equipment (WEEE) and supporting, from an environmental point of view and for the protection of the health of the worker, the intervention of the subjects who participate in the installation, use and disposal of their products (manufacturer, distributors, consumers, involved operators in WEEE treatment).

The crossed-out wheeled bin symbol (Fig. 48) contained on the equipment indicates that the product must be SEPARATELY collected from other type of waste at the end of operational life.

Therefore, the user must give the equipment at the end of its life to the appropriate waste collection centers for waste electrical and electronic equipment or return it to the retailer when purchasing a new equivalent type of equipment.

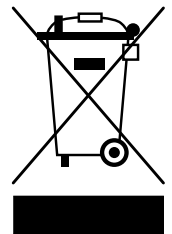

Fig. 48

Appropriate sorted waste collection for further sending of the fallen to disuse equipment for recycling, treatment and environmentally compatible disposal contributes to avoid possible negative effects on the environment and favors the reuse and/or recycling of the materials the equipment is made of. Unauthorized disposal of the product by the user results in the application of the administrative sanctions provided for by the applicable law.