



# DC PUMPS BP 3000 - BP 3000 INLINE

**EN.** Fuel vane pumps.  
Powerful, dependable and economical, they are available with 12 and 24-volt direct current motors.  
Thanks to their compact sizes, these pumps are used as the primary system in earthmoving machinery.

**ES.** Bombas de paletas para transferencia.  
Potentes, fiables y económicas, están disponibles con motor 12V y 24V de corriente continua.

*Por su estructura compacta, estas bombas son usadas como sistema primario and maquinaria de mover tierra.*

**PT.** Bombas de palhetas para transferência.  
Potentes, fiáveis e económicas, estão disponíveis com motor de corrente contínua 12 e 24 Volts.

Por serem compactas, estas bombas são usadas como primeiro sistema em máquinas de terraplanagem.

## PERFORMANCE

- Vane pump with rotor.
- By-pass valve incorporated into the pump body.
- Duty cycle 30 min.
- Flow rate up to 50 l/min
- Noise level below 70 dB
- 12 - 24 V DC operation

- Bomba de paletas con rotor
- Válvula de bypass incorporada
- Ciclo de funcionamiento de 30 minutos
- Caudal de hasta 50 l/min
- Nivel de ruido inferior a 70 dB
- Funcionamiento 12V - 24V CC

- Bomba de palhetas com rotor.
- Válvula de by pass incorporada no corpo da bomba.
- Ciclo de trabalho 30 min.
- Caudal até 50 l/min
- Ruído inferior a 70 dB
- Funcionamento 12 - 24 V DC

## DIMENSIONS

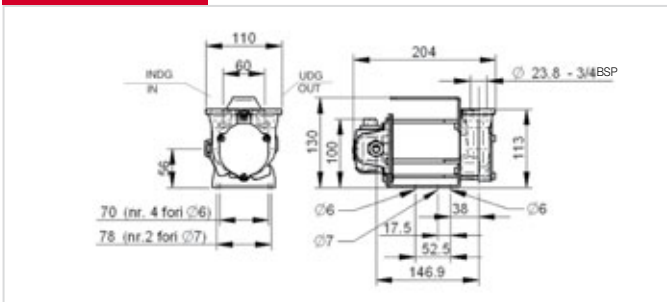

## GUARANTEE



**Guaranteed IP55 protection**  
Prevents water and dust entering the motor.



**EMC Test**  
No interference with power circuits.



**Vibration Test**  
Able to resist high vibrations.

## PRODUCTS' RANGE WEIGHT AND PACKAGING

Code	Weight		Packaging		
	kg	lbs	mm	inch	pcs/box
<b>F00342000</b>	3,5	7,9	200x120x140	7,9x4,7x5,5	1
<b>F00347000</b>	3,5	7,9	200x120x140	7,9x4,7x5,5	1
<b>F00357500</b>	3,5	7,9	200x120x140	7,9x4,7x5,5	1
<b>F00358500</b>	3,5	7,9	200x120x140	7,9x4,7x5,5	1



**REGISTERED DESIGN**

Flow-rate

up to  
**50** l/min  
(up to 13 gpm)



BP 3000 - PORTS NOT THREADED



BP 3000 INLINE - THREADED PORTS

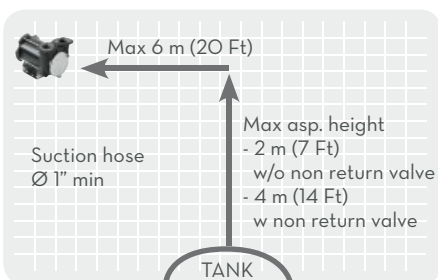
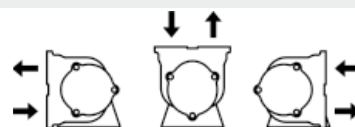
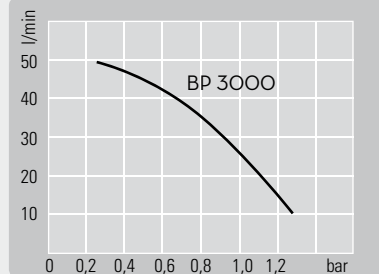

ON REQUEST



- KIT terminal box + 2mt cable + fuse 25A with clamp BP3000 12V - Code F16293000
- KIT terminal box + 4mt cable + fuse 25A with clamp BP3000 12V - Code F16295000
- KIT terminal box + 2mt cable + fuse 15A with clamp BP3000 24V - Code F16294000
- KIT terminal box + 4mt cable + fuse 15A with clamp BP3000 24V - Code F16296000



BP 3000 VERTICAL PORTS ONLY

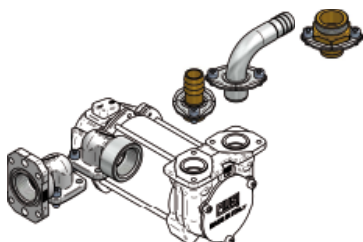

Kit straight hose tail  
3/4"  
Code F16172000  
(No.02 pcs)



90° hose tail 3/4"  
Code F16173000  
(No.01 pcs)



Flanged elbow 1" BSP  
Code F16178000  
(No.01 pcs)



Flanged elbow 1" BSP  
Code F16770000  
(No.01 pcs)

PRODUCTS' RANGE TECHNICAL DATA

Code	Description	Fluids type	Flow-rate		Voltage			rpm	Duty cycle min.	Max working pressure bar.
			l/min	gpm	DC Volt	Power Watt	Amp. max.			
F00342000	BP3000 12V	D	50	7	12	300	24	2900	30	1,5
F00347000	BP3000 24V / 12V	D	50/30	13/6	24/12	310/80	13/6,5	2900/1500	30	1,5
F00357500	BP3000 INLINE 12V	D	50	7	12	300	24	2900	30	1,5
F00358500	BP3000 INLINE 24V / 12V	D	50/30	13/6	24/12	310/80	13/6,5	2900/1500	30	1,5