

TECHNICAL FEATURES

- *Flow Rate:* Up to 3 L/H
- *Maximum Pressure:* 3 Bar
- *Power Supply:* 90-260v standard
- *Tubing:* Available in Santoprene®
- *Control:* Integral pH or Redox controller for proportional dosing
- *Level Control:* Supplied with level probe, alarm output relay
- *Measurement ranges:* pH: 5 – 9 pH
Redox: -300 - +900 mV
- *Alarms:* Low level; Overdosing



ACCESSORY KIT

- pH or Redox probe with 5 m cable
- Saddle clamps
- Probe holder
- Level probe
- Buffer solutions (either pH 7 & 9, or 650 mV dependent on pump configuration)
- Injection Valve (PVC/FPM)
- Foot Filter (PP/FPM)
- 2m suction & 2m discharge tubing

0184669328

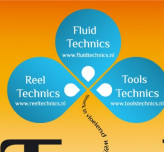
**FluidTechnics**
sterk in vloeïend werk

MODEL			
CXB400	ePool Peristaltic pump with integral pH or Redox control		
	FEATURES		
	Version	Flow rate (L/H)	Pressure (Bar)
03	0101	1.5	1.5
04	0301	3	1.5
05	0202	2	2
06	0303	3	3
	OPTIONS		
01	pH Kit		
02	Redox Kit		
Z6	No Kit		
CXB400	06	01	ePool pH; 3 L/H; 3 Bar; with full pH accessory kit

DIMENSIONS

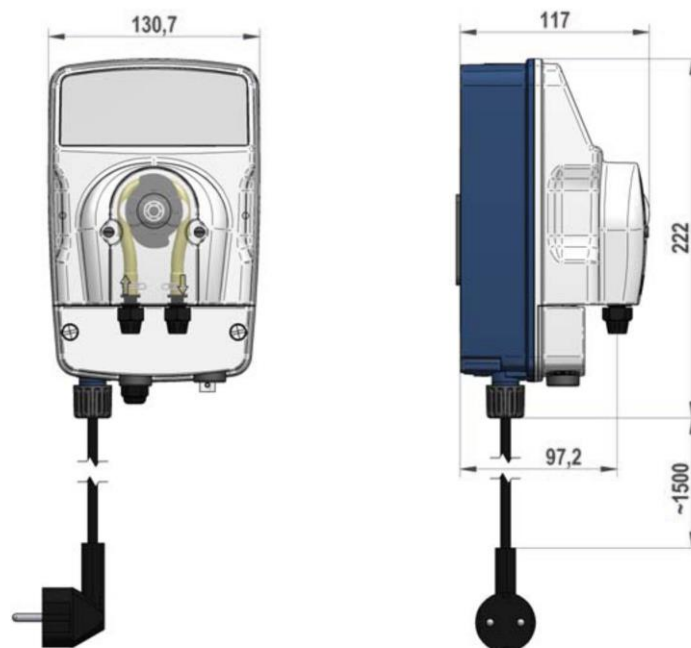

All dimensions are in mm