

**EBARA**

	Page
<b>- SPECIFICATIONS</b> <sup>①</sup>	<b>200</b>
PERFORMANCE RANGE and SELECTION CHART	201
TYPE KEY and CURVES SPECIFICATIONS	202
PERFORMANCE CURVES DWC 300	203
PERFORMANCE CURVES DWC 500	204
<b>- CONSTRUCTIONS</b>	<b>300</b>
SECTIONAL VIEW DRAWING	300
SECTIONAL VIEW TABLE	301
MECHANICAL SEAL	302
BEARINGS	303
THERMAL INSULATION	304
<b>- DIMENSIONS and WEIGHT</b>	<b>400</b>
DWC-V (VICTAULIC CONNECTION)	400
DWC-N (THREADED CONNECTION)	401
PACKING	402
<b>- TECHNICAL DATA</b>	<b>500</b>
MOTOR DATA	500
NOISE DATA	500

① click INDEX to jump CORRESPONDING SECTION

② click  to go back to INDEX

## SPECIFICATIONS

50Hz

Rev. H

PUMP		
Liquid Handled	Type of liquid	Moderate aggressive fluids, glycol solutions, liquids containing Impurities, liquids suitable for industrial washing equipments. Not suitable for drinking water. For other industrial fluids please contact our Technical Customer Service.
	Temperature [°C]	min. -15 max. +90 (Standard and Special mechanical seal) max. +110 (Optional mechanical seal)
0	Maximum working pressure [MPa]	0,8
Construction	Impeller	Closed centrifugal type
	Shaft seal type	Mechanical seal
	Bearing	Sealed ball bearing
Pipe Connection	Suction	DWC-V Victaulic connection Ø 2" (60.3mm) DWC-N G 2
	Discharge	DWC-V Victaulic connection Ø 2" (60.3mm) DWC-N G 2
Material	Casing	EN 1.4301 (AISI 304)
	Impeller	EN 1.4301 (AISI 304)
	Casing cover	EN 1.4301 (AISI 304)
	Shaft seal	Ceramic/Carbon/EPDM
	Casing cover	EN 1.4301 (AISI 304)
	Shaft	EN 1.4301 (AISI 304) (Wet extension)
	Bracket	Aluminium
Applicable standard of test		ISO 9906:2012 Grade 3B

MOTOR	
Type	Electric - TEFC Three Phase
Efficiency level (Reg. 640/2009)	IE2 from 1.1 kW up to 3.0 kW IE3 from 1.1 kW up to 3.0 kW
No. of Poles	2
Rotation speed [min <sup>-1</sup> ]	~ 2800
Insulation Class	F
Protection degree (CEI EN 60034-5)	IP 55
Power rating [kW]	1.1 ÷ 3
[HP]	1.5 ÷ 4
Frequency [Hz]	50
Voltage [V]	230/400 ±10%
Over load protection	User provide
Casing material	Aluminium
Base material/motor support	Aluminium
Dimensions of cable entry	PG11 - PG13.5 – M20x1.5 (see DIMENSIONS TABLE page 400)

PERFORMANCE RANGE

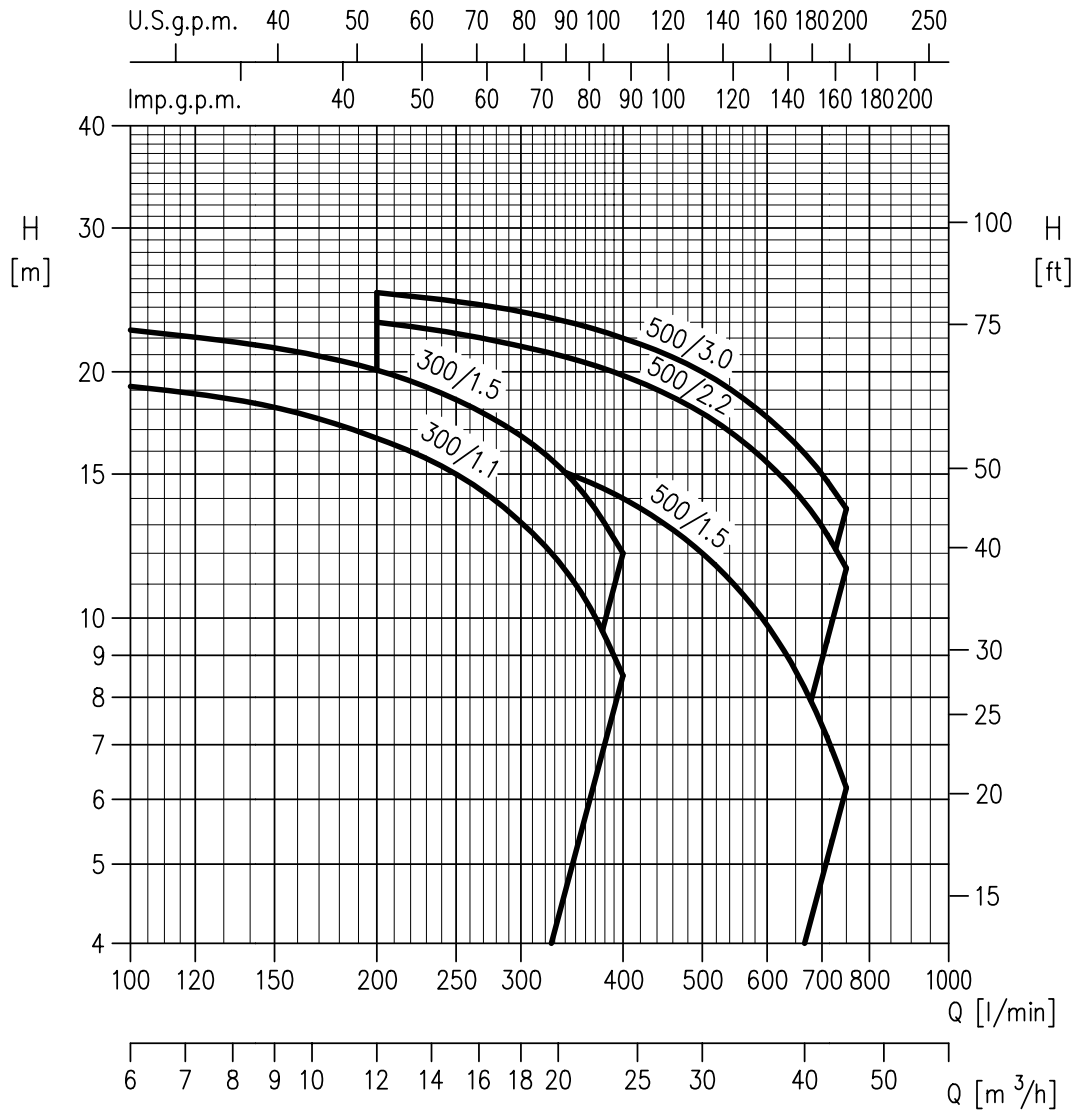

SELECTION CHART

Pump type	Power		Q=Capacity												
	[kW]	[HP]	l/min m³/h	0	100	150	200	250	300	350	400	500	600	700	750
DWC 300/1,1	1,1	1,5	21,0	19,2	18,1	16,6	15,0	13,1	11,0	8,5	-	-	-	-	-
DWC 300/1,5	1,5	2	24,5	22,5	21,4	20,1	18,5	16,7	14,6	12,0	-	-	-	-	-
DWC 500/1,5	1,5	2	18,5	-	-	17,0	16,4	15,7	14,9	14,0	12,0	9,8	7,4	6,2	-
DWC 500/2,2	2,2	3	24,5	-	-	23,0	22,3	21,5	20,7	19,8	17,8	15,5	13,0	11,5	-
DWC 500/3,0	3	4	26,3	-	-	25,0	24,4	23,7	22,9	22,0	20,0	17,6	15,0	13,6	-

## TYPE KEY and CURVES SPECIFICATIONS

50Hz

Rev. H

### TYPE KEY

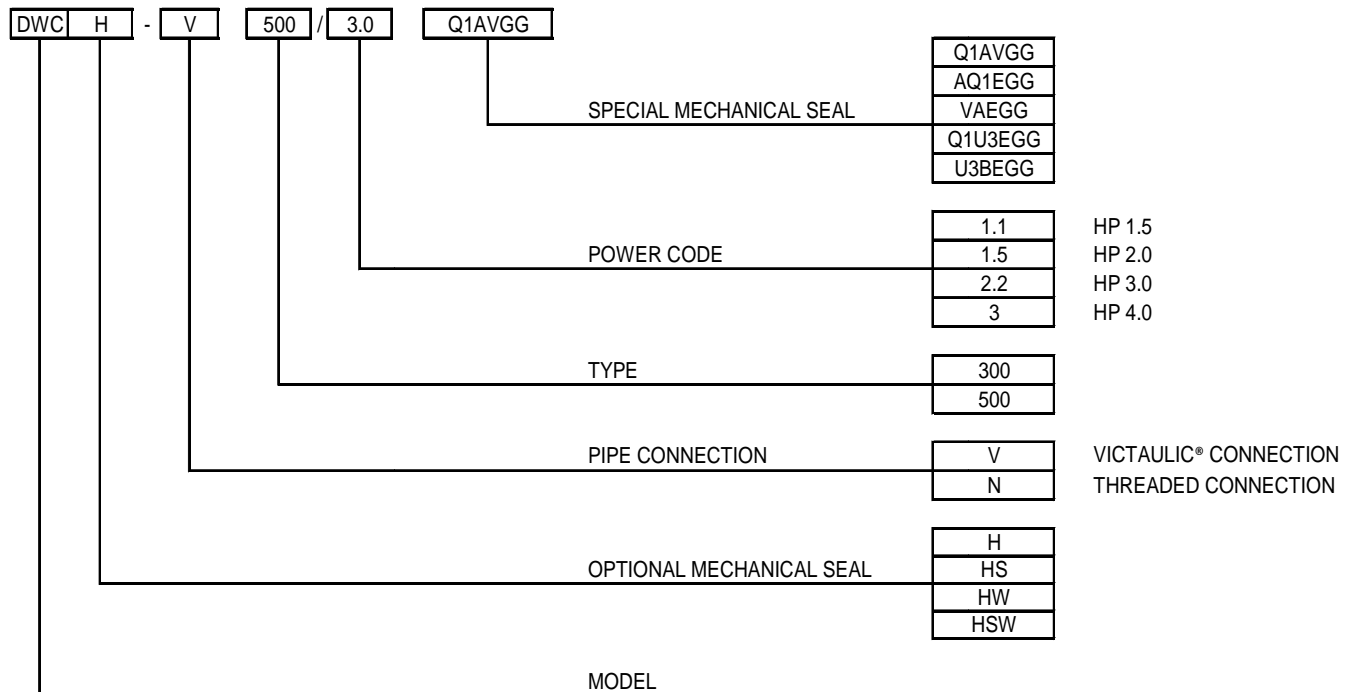

### CURVES SPECIFICATIONS

The specifications below qualify the curves shown on the following pages.

Tolerances according to ISO 9906:2016 - Grade 3B

The curves refer to effective speed of asynchronous motors at 50 Hz, 2 poles.

Measurements were carried out with clean water at 20°C of temperature and with a kinematic viscosity of  $\nu = 1 \text{ mm}^2/\text{s}$  (1 cSt)

The NPSH curve is an average curve obtained in the same conditions of performance curves.

The continuous curves indicate the recommended working range. The dotted curve is only a guide.

In order to avoid the risk of over-heating, the pumps should not be used at a flow rate below 10% of best efficiency point.

Symbols explanation:

- Q = volume flow rate
- H = total head
- $P_2$  = pump power input (shaft power)
- $\eta$  = pump efficiency
- NPSH = net positive suction head required by the pump

300/1.1 (1.1 kW) – Impeller diameter = 133 mm  
 300/1.5 (1.5 kW) – Impeller diameter = 148 mm

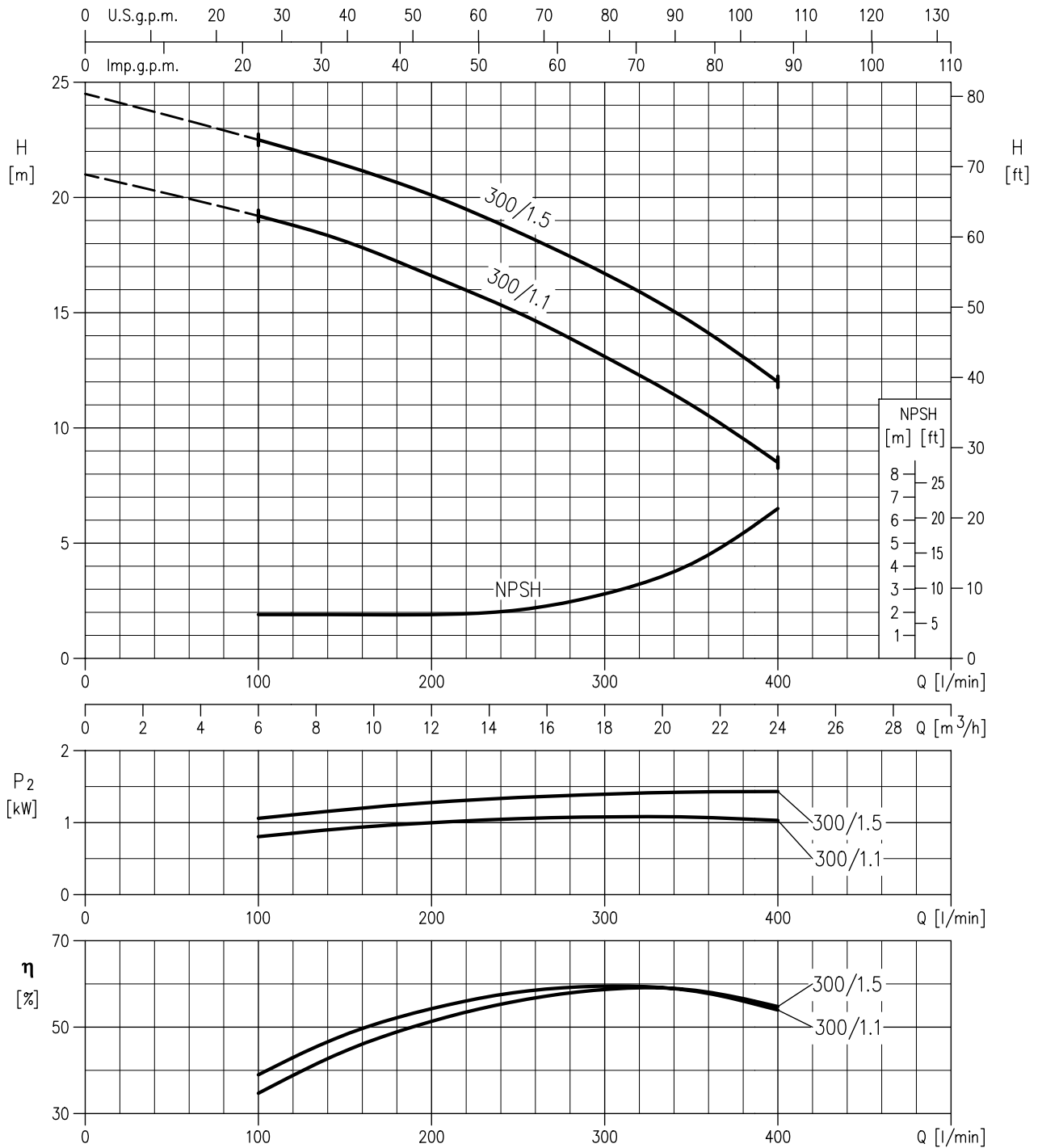

Rotation speed ≈ 2900 min<sup>-1</sup>  
 Test standard: ISO 9906:2012 - Grade 3B

500/1.5 (1.5 kW) – Impeller diameter = 125 mm  
 500/2.2 (2.2 kW) – Impeller diameter = 140 mm  
 500/3.0 (3.0 kW) – Impeller diameter = 148 mm

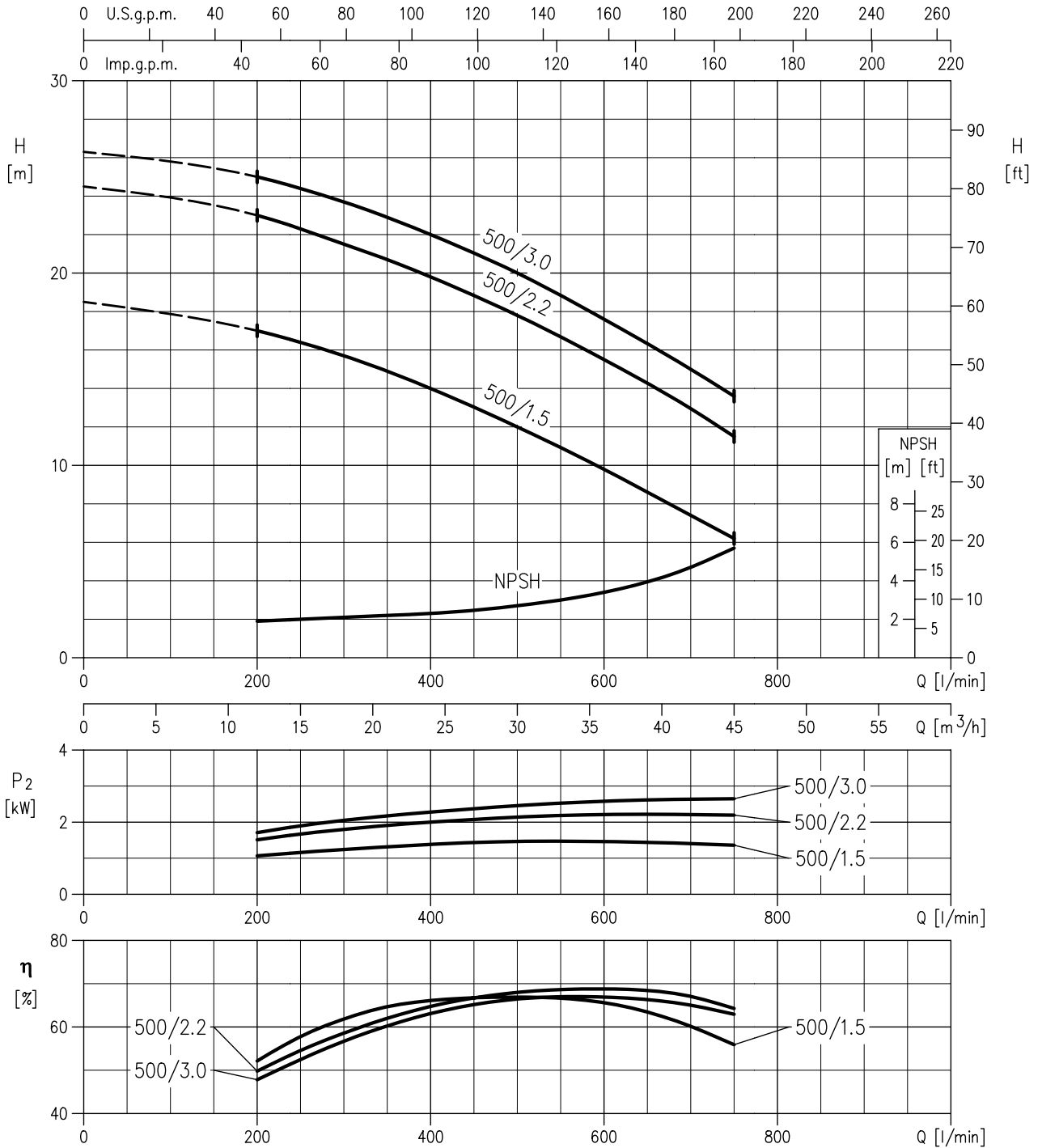

Rotation speed  $\approx 2900 \text{ min}^{-1}$   
 Test standard: ISO 9906:2012 - Grade 3B

**SECTIONAL VIEW DRAWING**  
DWC-V (Victaulic connection)

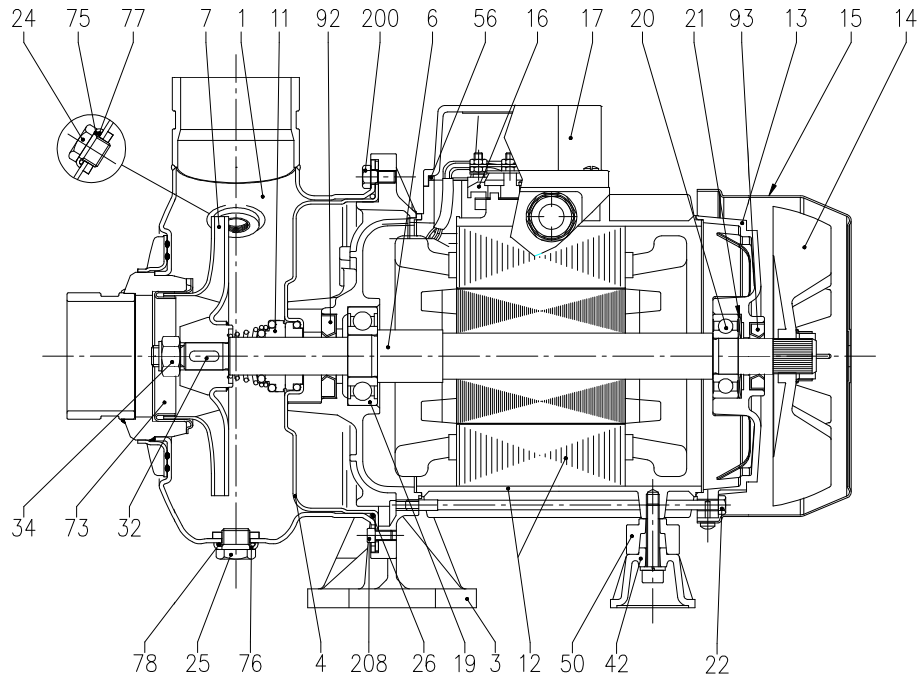

**DWC-N (Threaded connection)**

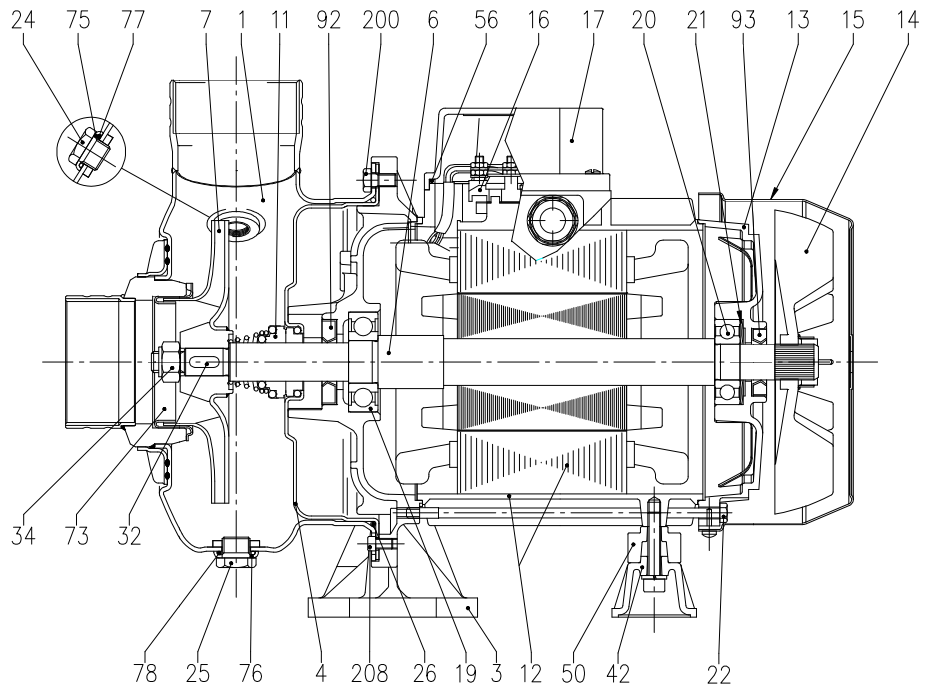



## SECTIONAL VIEW TABLE

N°	PART NAME	MATERIAL	DIMENSIONS	STANDARD	Q.TY	
1	Casing	EN 1.4301 (AISI 304)			1	
3	Motor bracket	Aluminium			1	
4	Casing cover	EN 1.4301 (AISI 304)			1	
6	Shaft with rotor	EN 1.4301(AISI 304)-Wet extension			1	
7	Impeller	EN 1.4301 (AISI 304)			1	
11	Mechanical seal [3]	Ceramic / Carbon / EPDM			1	
12	Motor frame with stator	-			1	
13	Motor cover	Aluminium			1	
14	Fan	PA			1	
15	Fan cover	Fe P04 Zincate			1	
16	Terminal board	-			1	
17	Terminal board cover	Aluminium			1	
19	Bearing [4]	-			1	
20	Bearing [4]	-			1	
21	Adjusting ring	Steel C70			1	
22	Tie rod	Fe 42 Zincate		EBARA drawing	4	
24	Priming plug	EN 1.4301 (AISI 304)	G 1/4"	EBARA drawing	1	
25	Draing plug	EN 1.4301 (AISI 304)	G 1/4"	EBARA drawing	1	
26	O-ring [2]	EPDM / FPM	148.8x3.53	OR 4587	1	
32	Key	EN 1.4401 (AISI 316)	5x5x16	UNI 6604	1	
34	Impeller nut	EN 1.4301 (AISI 304)	M10x1.25	UNI 7474	1	
42	Foot	Aluminium / Zincate steel		EBARA drawing	1	
50	Spacer	-			[1]	
56	Box gasket	NBR			1	
73	Casing ring	EN 1.4301 (AISI 304)			1	
75	Washer	EN 1.4301 (AISI 304)		EBARA drawing	1	
76	Washer	EN 1.4301 (AISI 304)		EBARA drawing	1	
77	O-ring [2]	EPDM / FPM	13.1x2.62	OR 117	1	
78	O-ring [2]	EPDM / FPM	13.1x2.62	OR 117	1	
92	Lip seal	-	18x40x7	DIN 3760 without spring	1	
93	Lip seal		Up to 1.5 kW For 2.2 and 3.0 kW	-		
				17x32x7 25x40x7	DIN 3760 without spring	1
200	Screw	Stainless steel A2-70 class ISO 3506/1	M 6x12	UNI 5739	6	
208	Screw	Stainless steel A2-70 class ISO 3506/1	M 5x12	UNI 5931	4	

[1] Q.TY=1 only for 1,1 kW and 1,5 kW

[2] FPM for H-HS-HW-HSW-Q1AVGG (see pages 302, 303)

EPDM for STANDARD-AQ1EGG-VAEGG-Q1U3EGG-U3BEGG (see pages 302, 303)

[3] See **MECHANICAL SEAL** pages 302, 303

[4] See **BEARINGS** page 303

MECHANICAL SEAL

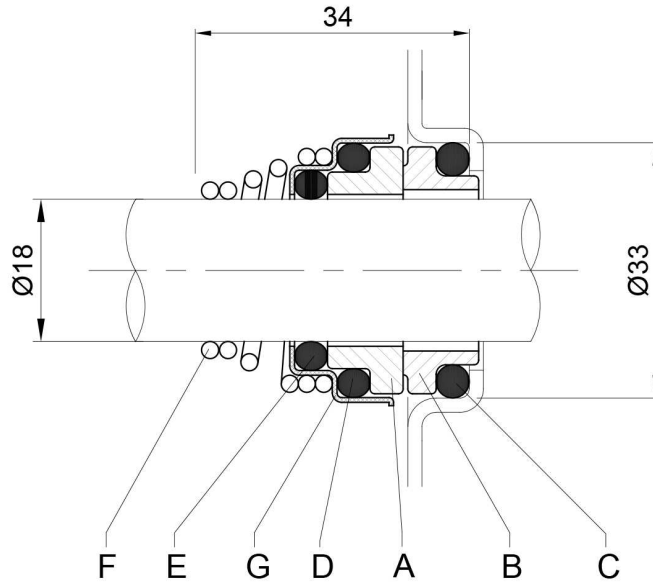

STANDARD

REF	PART NAME	MATERIAL
A	Rotary seal ring	Ceramic
B	Stationary seal ring	Carbon graphite
C	O-ring	EPDM
D	O-ring	EPDM
E	O-ring	EPDM
F	Self driving spring	AISI 316
G	Frame	AISI 304

OPTIONAL

REF	PART NAME	MATERIAL			
		H	HS	HW	HSW
A	Rotary seal ring	Ceramic	Silicon carbide	Tungsten carbide	Silicon carbide
B	Stationary seal ring	Carbon graphite	Silicon carbide	Tungsten carbide	Tungsten carbide
C	O-ring	FPM	FPM	FPM	FPM
D	O-ring	FPM	FPM	FPM	FPM
E	O-ring	FPM	FPM	FPM	FPM
F	Self driving spring	AISI 316	AISI 316	AISI 316	AISI 316
G	Frame	AISI 304	AISI 316	AISI 316	AISI 316

SPECIAL

REF	PART NAME	MATERIAL			
		Q1AVGG	VAEGG	Q1U3EGG	U3BEGG
A	Rotary seal ring	Silicon carbide	Ceramic	Silicon carbide	Tungsten carbide
B	Stationary seal ring	Metallised carbon	Metallised carbon	Tungsten carbide	Graphite
C	O-ring	FPM	EPDM	EPDM	EPDM
D	O-ring	FPM	EPDM	EPDM	EPDM
E	O-ring	FPM	EPDM	EPDM	EPDM
F	Self driving spring	AISI 316	AISI 316	AISI 316	AISI 316
G	Frame	AISI 316	AISI 316	AISI 316	AISI 316

MECHANICAL SEAL

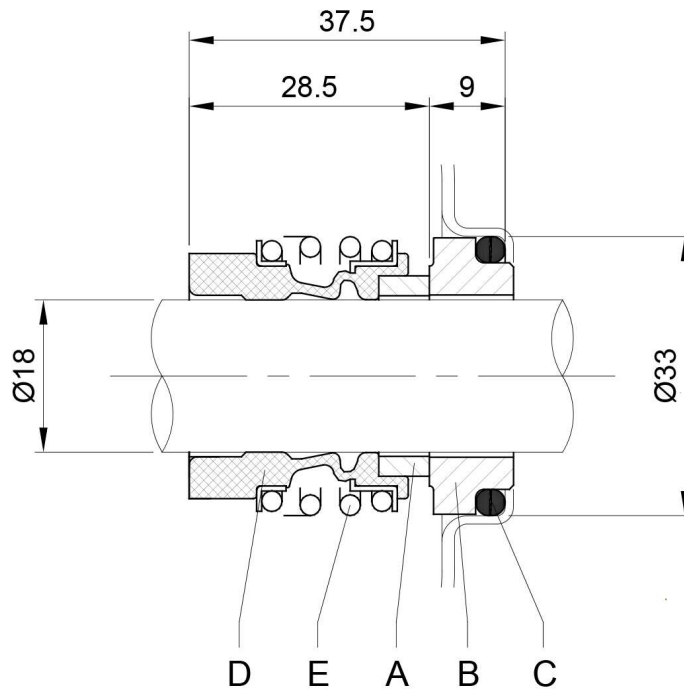

SPECIAL

REF	PART NAME	MATERIAL
		<b>AQ1EGG</b>
A	Rotary seal ring	Metallised carbon
B	Stationary seal ring	Silicon carbide
C	O-ring	EPDM
D	Bellows	EPDM
E	Frame + spring	AISI 316

BEARINGS

Pump type	Ball Bearing			
	Pump side		Fan side	
		(*)		(*)
DWC 300/1,1	6204 2RSH	6204-ZZ C3	6204 2RSH	6203-ZZ C3
DWC 300/1,5	6204 2RSH	6204-ZZ C3	6204 2RSH	6203-ZZ C3
DWC 500/1,5	6204 2RSH	6204-ZZ C3	6204 2RSH	6203-ZZ C3
DWC 500/2,2	6305 2RS1	6203-ZZ C3	6305 2RSH	6204-ZZ C3
DWC 500/3,0	6305 2RS1	6305-ZZ C3	6305 2RSH	6205-ZZ C3

(\*) Only for IE3 Motors

THERMAL INSULATION

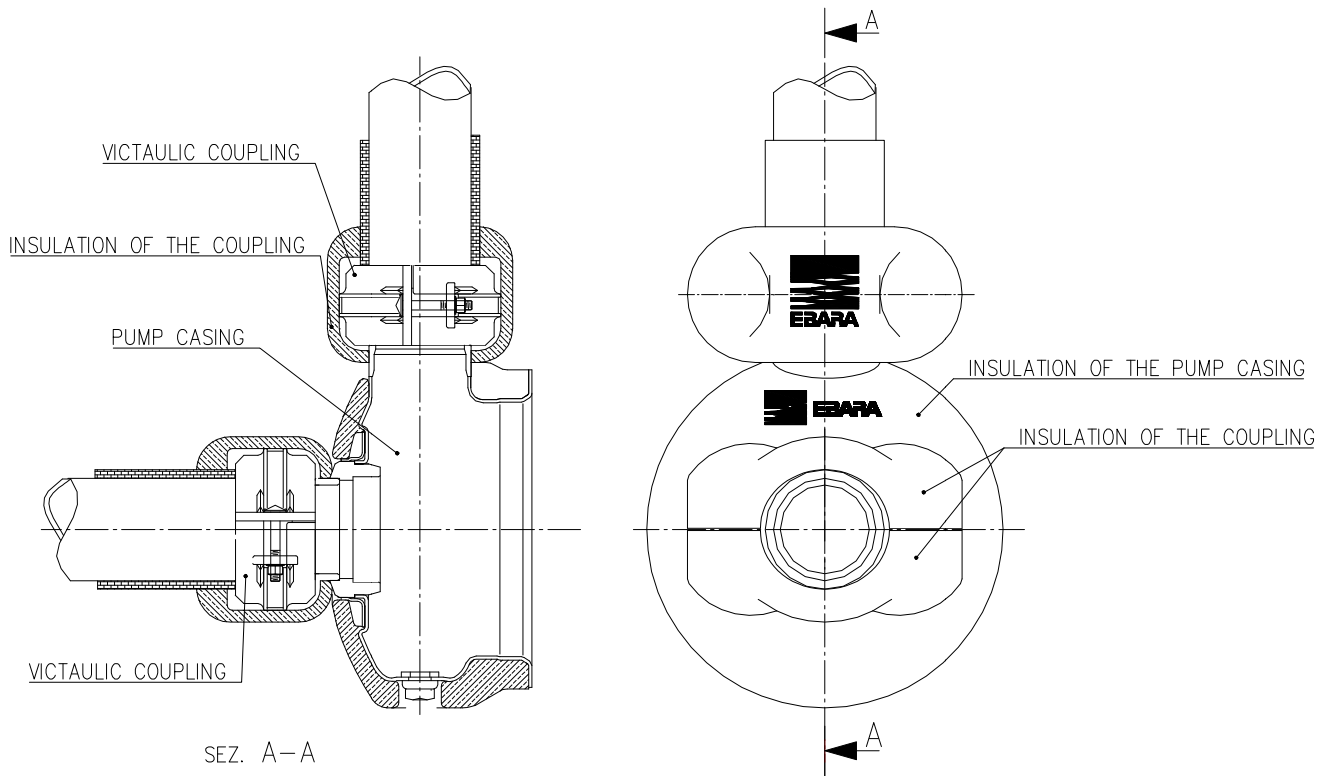

Pump type		INSULATION OF THE PUMP CASING	INSULATION OF THE COUPLING	VICTAULIC COUPLING
VICTAULIC® CONNECTION	DWC-V 300/1.1	STANDARD	ON REQUEST	ON REQUEST
	DWC-V 300/1.5			
	DWC-V 500/1.5			
	DWC-V 500/2.2			
	DWC-V 500/3.0			
THREADED CONNECTION	DWC-N 300/1.1	ON REQUEST	NOT NECESSARY	NOT NECESSARY
	DWC-N 300/1.5			
	DWC-N 500/1.5			
	DWC-N 500/2.2			
	DWC-N 500/3.0			

### DWC-V (VICTAULIC CONNECTION)

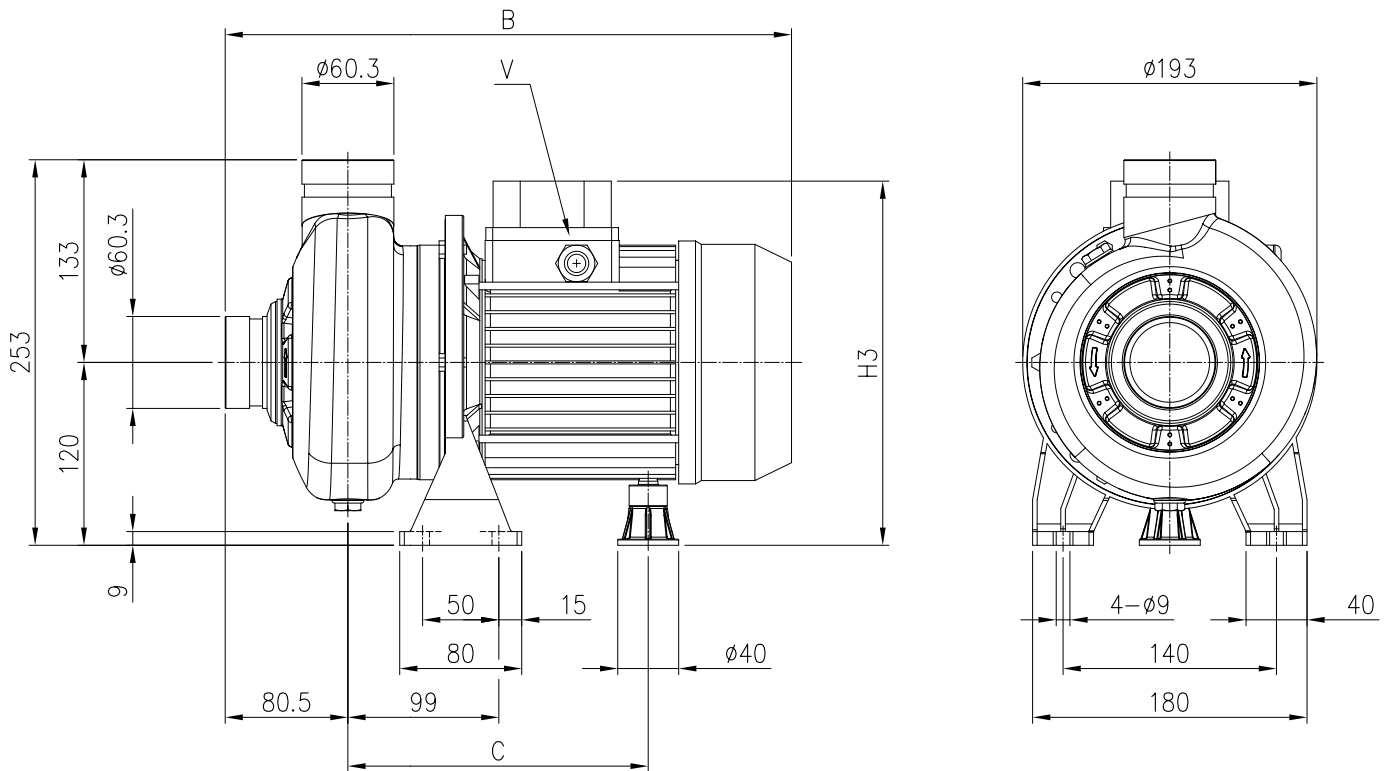

Pump type	Dimensions [mm]								Weight [kgf]	
	B	(*)	C	(*)	H3	(*)	V	(*)		(*)
DWC-V 300/1.1	372	397	197	197	239	239	PG11	M20x1.5	14,5	15,4
DWC-V 300/1.5	385	397,5	197	197	239	239	PG11	M20x1.5	16	16,9
DWC-V 500/1.5	385	397,5	197	197	239	239	PG11	M20x1.5	17	17,9
DWC-V 500/2.2	418	396,5	230 ÷ 241	197	244	239	PG13.5	M20x1.5	20,3	20,3
DWC-V 500/3.0	457	457	230 ÷ 241	230 ÷ 241	244	244	PG13.5	M20x1.5	22,3	22,3

(\*) Only for IE3 Motors

DWC-N (THREADED CONNECTION)

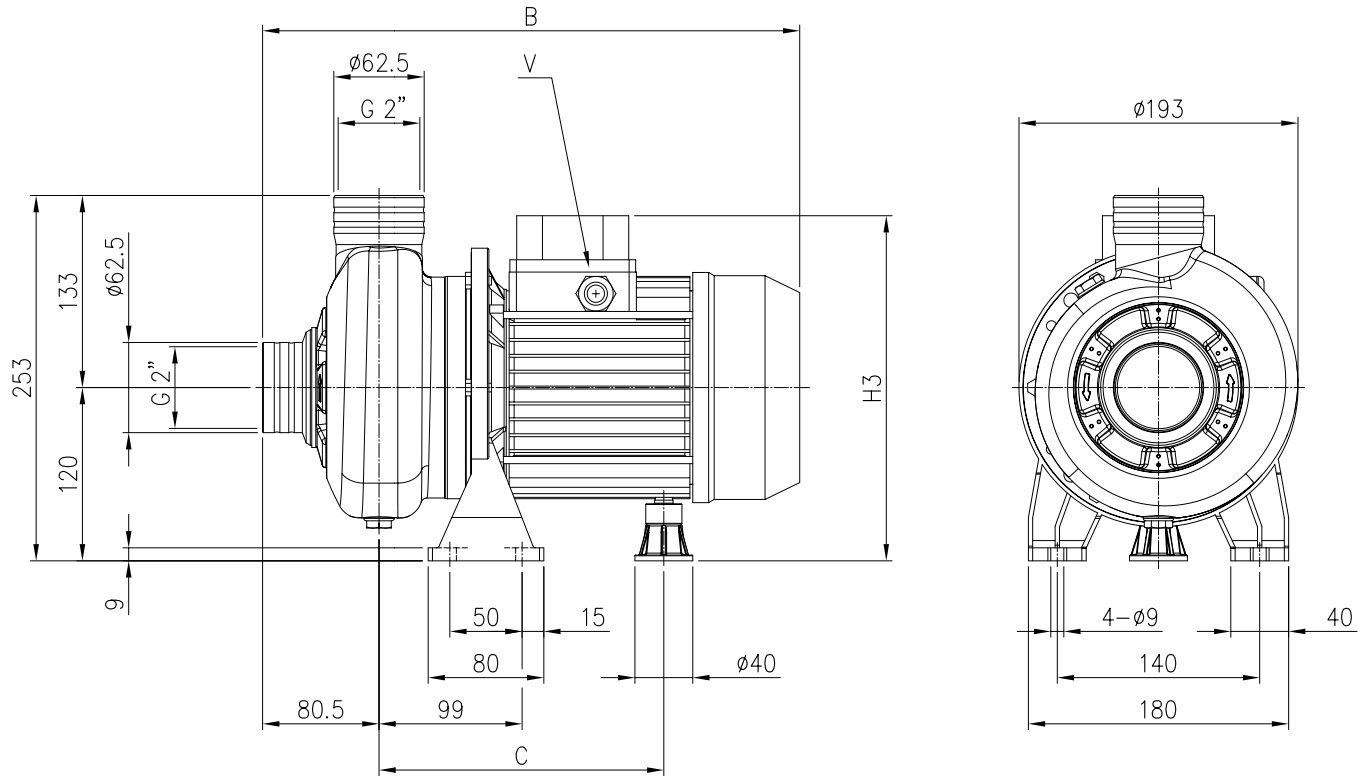

Pump type	Dimensions [mm]						Weight [kgf]	
	B	C	H3	V				
DWC-N 300/1.1	372	197	239	PG11			14,5	
DWC-N 300/1.5	385	197	239	PG11			16	
DWC-N 500/1.5	385	197	239	PG11			16,5	
DWC-N 500/2.2	418	230 ÷ 241	244	PG13.5			20,3	
DWC-N 500/3.0	457	230 ÷ 241	244	PG13.5			22,3	

(\*) Only for IE3 Motors

## PACKING

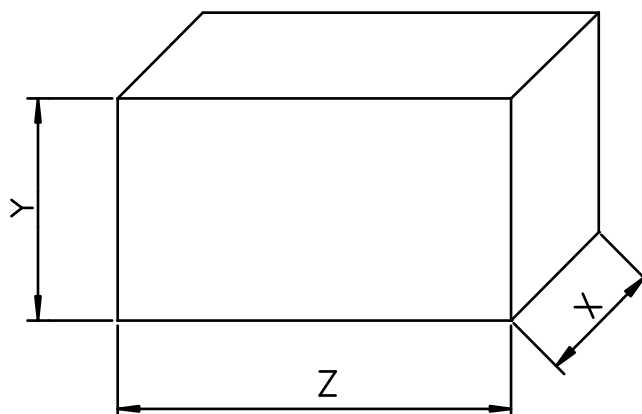

Pump type	Packing [mm]			Weight [kgf]	
	X	Y	Z		(*)
DWC 300/1.1	205	280	432	15,5	16,4
DWC 300/1.5	205	280	432	17	17,9
DWC 500/1.5	205	280	432	18	18,9
DWC 500/2.2	205	280	432	21,5	21,5
DWC 500/3.0	205	280	477	23,5	23,5

(\*) Only for IE3 Motors

## MOTOR DATA

Pump type	Power		Efficiency	Efficiency (% load)			Input [kW]	Full load current [A]		Locked rotor current [A]	
	[kW]	[HP]		$\eta$ %				230 V	400 V	230 V	400 V
				50%	75%	100%					
DWC 300/1.1	1.1	1.5	IE2	79.7	82.5	83.0	1.80	5.5	3.2	45.0	25.7
DWC 300/1.1	1.1	1.5	IE3	83.5	84.3	84.6	1.77	5.8	3.3	47.4	27.4
DWC 300/1.5	1.5	2.0	IE2	78.6	83.0	84.2	1.78	6.3	3.7	59.0	34.3
DWC 300/1.5	1.5	2.0	IE3	82.7	86.1	87.0	1.72	6.6	3.8	66.6	38.4
DWC 500/1.5	1.5	2.0	IE2	78.6	83.0	84.2	1.78	6.3	3.7	59.0	34.3
DWC 500/1.5	1.5	2.0	IE3	82.7	86.1	87.0	1.72	6.6	3.8	66.6	38.4
DWC 500/2.2	2.2	3.0	IE2	83.1	85.7	86.2	2.55	7.8	4.5	75.0	43.5
DWC 500/2.2	2.2	3.0	IE3	86.2	87.0	86.0	2.55	8.2	4.7	66.6	38.4
DWC 500/3.0	3.0	4.0	IE2	85.0	86.7	86.3	3.48	10.6	6.1	100.0	57.7
DWC 500/3.0	3.0	4.0	IE3	85.9	87.5	87.1	3.44	11.1	6.4	90.0	52.0

## NOISE DATA

Pump type	Power		$L_{pA}$ - dB(A) *
	[kW]	[HP]	
DWC 300/1.1	1,1	1,5	<70
DWC 300/1.5	1,5	2,0	
DWC 500/1.5	1,5	2,0	
DWC 500/2.2	2,2	3,0	
DWC 500/3.0	3,0	4,0	

\* Mean value of several measures at 1m distance around the  
Tolerance  $\pm 2.5$  dB.