

EN Double filter, triple control.

This filtering unit provides double filtering for oil and diesel fuel and absorbs any water and impurities.

What is more, it can be equipped with electronics for controlling and automating the two functions:

- determine the filtering time in relation to the quantity to be processed,
- switch off automatically in case of filter blockage.

The unit features a supply and suction pipe with integrated bottom valve.

Features:

Sturdy wheeled structure,
Large-diameter wheels,
Flow rate 56 l/min.,
Filtering capacity – first stage 30 µ with water absorption,
second stage 5 µ for impurities.
Voltage 230/50 Hz.





Group composition:

- Vane pump
- Suction, 4 m. 3/4 hose with no back valve
- Delivery 4 m 3/4 hose
- Manual nozzle
- Water absorption filter 30 micro
- Impurities filter 5 micro

Optional:

- Electronic panel for filtration control



Code	Description	Flow rate		Type	Pump				Hose lenght (m)		Weight Kg	Packaging mm
		l/min	gal/min		Tension V	Amp	Freq. Hz	Power Watt	delivery	suction		
F00506000	Filtroll Diesel 	56	15	Panther 56	230	-	50	375	4	3	35	600x600x1300
F00506010	Filtroll Oil/Diesel 	25	7	Viscomat 70	230	-	50	750	3	3	42	600x600x1300
F00506050	Filtroll Diesel 12 V 	50	13	BP 3000	12	22	-	-	4	4	35	600x600x1300
F00506060	Filtroll Diesel 24 V 	50	13	BP 3000	24	11	-	-	3	3	35	600x600x1300

FI Doppio filtro, triplo controllo.

Questo gruppo filtrante assicura la doppia filtrazione per olio e gasolio assorbendo acqua ed impurità presenti. Inoltre può essere equipaggiato con una elettronica per il controllo e l'automazione di due funzioni:
- determinare il tempo di filtraggio in rapporto alla quantità da processare,
- spegnere automaticamente in caso di intasamento del filtro. Il gruppo è dotato di tubo di mandata ed aspirazione con valvola di fondo integrata.

Caratteristiche:

Robusta struttura carrellata,
Ruote di grande diametro,
Portata 56 l/min.,
Capacità filtrante primo stadio 30 µ con assorbimento acqua, secondo stadio 5 µ per impurità.
Tensione 230/50 Hz.

FB Double filtre, triple contrôle.

Ce groupe filtrant garantit un double filtrage pour huile et gazole en absorbant l'eau et les impuretés présents. De plus, il peut être équipé d'une électronique pour le contrôle et l'automatisation de deux fonctions:
- déterminer le temps de filtrage par rapport à la quantité à traiter,
- éteindre automatiquement en cas d'encrassement du filtre. Le groupe est doté d'un tuyau flexible de refoulement et d'aspiration avec clapet de pied incorporé.

Caractéristiques:

Structure à chariot solide,
Roues de grand diamètre,
Débit 56 l/min.,
Capacité de filtrage première phase 30 µ avec absorption d'eau, deuxième phase 5 µ pour impureté.
Tension 230/50 Hz.

DE Doppelfilter, Dreifachkontrolle.

Mithilfe dieses Filteraggregats wird die doppelte Filterung für Öl und Diesel durch Absorption von Wasser und vorhandenen Verunreinigungen gewährleistet. Darüber hinaus kann es mit einer Elektronik für die Kontrolle und Automatisierung von zwei Funktionen ausgestattet werden:
- Bestimmung der Filterzeit je nach zu verarbeitender Menge,
- automatische Abschaltung bei Verstopfung des Filters. Das Aggregat verfügt über eine Druck- und Saugleitung mit integriertem Grundventil.

Eigenschaften:

Robustes Rollgestell,
Räder mit großem Durchmesser,
Leistung 56 l/min.,
Filterleistung erste Stufe 30 µ mit Wasserabsorption, zweite Stufe 5 µ für Verunreinigungen.
Spannung 230/50 Hz.

ES Doble filtro, triple control.

Este grupo filtrante asegura doble filtración de aceite y gasoleo absorbiendo agua y suciedad. Además se puede instalar tarjeta electrónica por el control de dos funciones:
- determinar el tiempo de filtraje en referencia a la cantidad que tiene que limpiar;
- apagar la bomba si el filtro se obstruye. El grupo está dotado de manguera de succión y suministro con valvula de pie.

Características:

Estructura robusta con carretilla,
Ruedas de grande diámetro
Caudal 56 l/min
Capacidad de filtración: primero filtro por agua 30 µ, segundo filtro por suciedad 5 µ.
Voltaje: 230/50 Hz

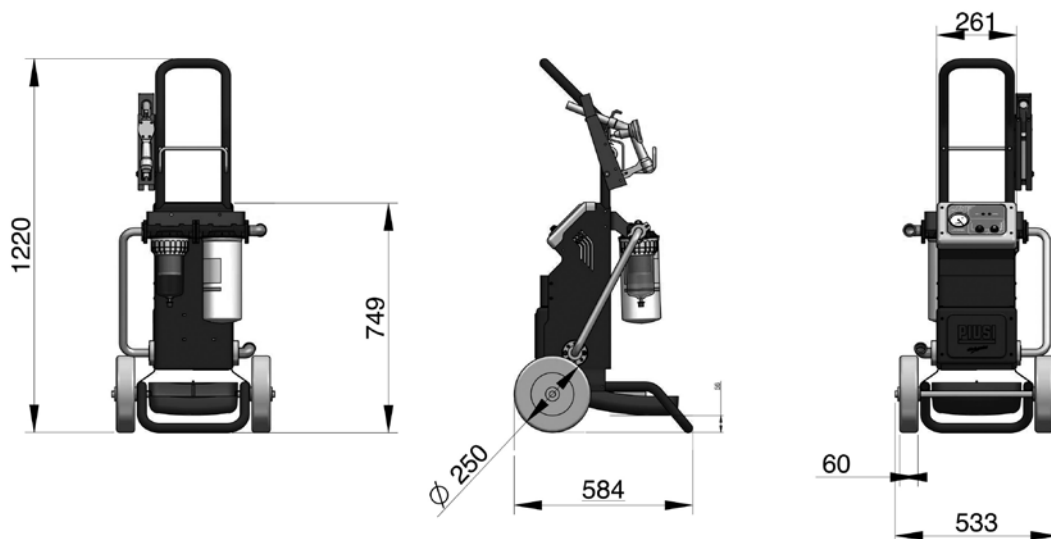

The Company reserves the right to modify the information contained in this catalogue without any prior notice.



Certified
ISO 9001 / ISO 14001

PIUSI S.p.A.
46029 Suzzara (Mantova) ITALY
Tel. +39-0376.534561
Fax: +39-0376.536393
e-mail: piusi@piusi.com
www.piusi.com

PIUSI USA, Inc.
2365 SW 34th St.
FORT LAUDERDALE, FL 33312, USA
Tel. : +1 954 584 1552
Fax.: +1 954 584 1554
e-mail: piusiusa@piusiusa.com
www.piusiusa.com

